

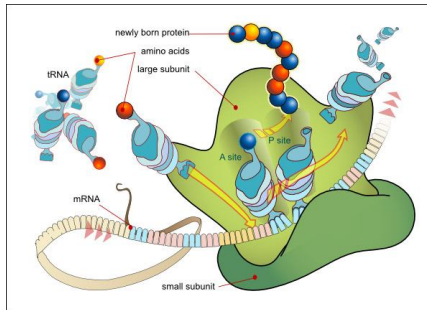

# Vardhman Mahaveer Open University, Kota



## Cell, Molecular Biology and Biotechnology

MZO-02



**Vardhman Mahaveer Open University, Kota**

**Cell, Molecular Biology and Biotechnology**

---

## Course Development Committee

---

### Chair Person

**Prof. Vinay Kumar Pathak**

Vice-Chancellor

Vardhman Mahaveer Open University, Kota

---

### Coordinator and Members

---

#### Convener

**SANDEEP HOODA**

**Department of Zoology**

School of Science & Technology

Vardhman Mahaveer Open University, Kota

#### Members

- **Prof. L.R.Gurjar**  
Director (Academic)  
Vardhman Mahaveer Open  
University, Kota
  - **Dr. Arvind Pareek**  
Director (Regional Centre)  
Vardhman Mahaveer Open  
University, Kota
  - **Prof. Maheep Bhatnagar**  
MLSU, Udaipur
  - **Dr. Anuradha Singh**  
Department of Zoology  
Govt. College, Kota
  - **Dr. Anuradha Dubey**  
**Deputy Director**  
School of Science & Technology  
Vardhman Mahaveer Open  
University, Kota
  - **Prof. K.K. Sharma**  
MDSU, Ajmer
  - **Prof. S.C. Joshi**  
**University of Rajasthan, Jaipur**
  - **Dr. M.M.Ranga**  
Department of Zoology  
Govt. College, Ajmer
- 

#### Editing and Course Writing

---

##### Editor

**SANDEEP HOODA**

**Assistant Professor**

**& Convener of Zoology**

School of Science & Technology

Vardhman Mahaveer Open University, Kota

## Writing

Writer Name	Unit No.	Writer Name	Unit No.
<b>Dr. Subhash Chandra</b> Director (Regional Centre) Vardhman Mahaveer Open University, Kota	1	<b>Sandeep Hooda</b> Department of Zoology School of Science & Technology Vardhman Mahaveer Open University, Kota	2
<b>Dr. Digvijay Singh</b> Lecture in Zoology Assistant Director, Bikaner Directorate of College Education, Rajasthan	3, 4	<b>Dr. Anima Sharma</b> Dept. of Biotechnology, JECRC University, Jaipur	5,8,9,10, 13
<b>Dr. Arvind Pareek</b> Director (Regional Centre) Vardhman Mahaveer Open University, Kota	6, 16	<b>Dr. Farah Sye</b> Dept. of Zoology, University of Rajasthan, Jaipur <b>Dr. Meera Shrivastva</b> Dept. of Zoology Govt. Dungar College, Bikaner	7
<b>Dr. Ruchi Seth</b> Dept. of Biotechnology, JECRC University, Jaipur	11	<b>Dr. Hardik Pathak</b> Dept. of Biotechnology, JECRC University Jaipur	12, 15
<b>Dr. Abhisekh Vashistha</b> Dept. of Microbiology, Maharaja Ganga Singh University, Bikaner	14		

---

### Academic and Administrative Management

---

<b>Prof. Vinay Kumar Pathak</b> Vice-Chancellor Vardhman Mahaveer Open University, Kota	<b>Prof. L.R. Gurjar</b> Director (Academic) Vardhman Mahaveer Open University, Kota
<b>Prof. Karan Singh</b> Director (MP&D) Vardhman Mahaveer Open University, Kota	<b>Dr. Subodh Kumar</b> Additional Director (MP&D) Vardhman Mahaveer Open University, Kota

---

### ISBN :

All Right reserved. No part of this Book may be reproduced in any form by mimeograph or any other means without permission in writing from V.M. Open University, Kota.

Printed and Published on behalf of the Registrar, V.M. Open University, Kota.

Printed by :





## Vardhman Mahaveer Open University, Kota

### Index

Unit No.	Unit Name	Page No.
Unit - 1	Microscopy	1
Unit - 2	Cytological techniques: Staining techniques ,isolation and fractionation of cell , Cell Culture,. Centrifugation and Ultracentrifugation, Electrophoresis, Chromatography, Cytometry	11
Unit - 3	Plasma membrane and intracellular compartments	38
Unit - 4	Vesicular Traffic Organelles	60
Unit - 5	Energy transducers and other organelles	75
Unit - 6	Cell Signalling	86
Unit - 7	Signaling pathways in malignant transformation of cells, cell transformation, role of oncogenes, siRNA and miRNA basics, regulation of transcription and translation of proteins by miRNA	102
Unit - 8	Chromosomes	125
Unit - 9	Genome expression analysis: FISH, GISH, M-FISH, Minichromosomes and Giant chromosomes Gene expression; Process of gene expression: Translation, Transcription; Gene control regions; Gene expression	141

	analysis techniques; Giant chromosomes Minichromosomes	
Unit - 10	Cell cycle, Mitosis and Meiosis	162
Unit - 11	Biotechnology basics: Genetic engineering, culture media, culture methods, restriction enzymes, cloning vectors, somatic hybridization	179
Unit - 12	Recombinant DNA Technology	232
Unit - 13	Bioreactors and downstream processing	257
Unit - 14	Biotechnology in Medicine	272
Unit - 15	Molecular mapping of Genome	316
Unit - 16	Gene Regulation	344



## Vardhman Mahaveer Open University, Kota

### Preface

The present book entitled “**Cell, Molecular Biology and Biotechnology**” has been designed so as to cover the unit-wise syllabus of MZ-02 course for M.Sc. Zoology (Previous) students of Vardhman Mahaveer Open University, Kota. The basic principles and theory have been explained in simple, concise and lucid manner. Adequate examples, diagrammes, photographs and self-learning exercises have also been included to enable the students to grasp the subject easily. The unit writers have consulted various standard books and internet on the subject and they are thankful to the authors of these reference books.

-----

# Unit-1

---

## Microscopy

---

### Structure of the Unit

- 1.0 Objectives
- 1.1 Introduction
  - 1.1.1 Refractive index
  - 1.1.2 The Lenses
- 1.2 Light Microscopy
- 1.3 Electron Microscopy
- 1.4 Atomic Force Microscopy
- 1.5 Summary
- 1.6 Self-Learning Exercise
- 1.7 References

---

### 1.0 Objectives

---

After going through this unit you will be able to understand

- How small organisms and small sections of animal and plants may be enlarged using lenses.
- The mechanisms of Microscopes to resolve the objects.
- That different microscopes are used to study different small objects as we are not able observe them by naked eyes.

---

### 1.1 Introduction

---

This is the most essential lesson for a student before you start reading about Instrumentation. Different scientists have contributed a lot to develop Microscopes. Antony van Leeuwenhoek (1632-1723) was the first person to observe and describe micro-organisms accurately.

The optical microscope was first used systematically by Robert Hooke in 1664 to study polished sections of opaque materials, notably metals and alloys, and, he was able to reveal distinct phases in a microstructure. Notably, the optical microscope remains the fundamental tool for phase identification. It magnifies an image by sending a beam of light through the object. The condenser lens

focuses the light on the sample and the objective lenses (10X to 100-2000X) magnify the beam, which contains the image, to the projector lens so the image can be viewed by the observer. In compound microscopes there is combined effect of two or more than two lenses where as generally one lens is used to enlarge the object in dissecting microscopes. We shall discuss compound microscopes in detail here.

The lenses are used in Microscopes and there is the bending of light when passing through lenses. As you know light is refracted (bent) when passing from one medium to another.

### **1.1.1 Refractive index**

It is a measure of how greatly a substance slows the velocity of light. One important part is that; direction and magnitude of bending is determined by the refractive indexes of the two media forming the interface

### **1.1.2 The Lenses**

The Focus light rays at a specific place called the focal point and the distance between center of lens and focal point is the focal length. One another important aspect is that the strength of lens is related to focal length. Thus; if the short focal length, there will be more magnification.

---

## **1.2 The Light Microscope**

---

Many types of light microscopes have been discovered and they are called as per their light background as well as their functioning. They have different properties also (Table 1). The light microscopes are of following types:

1. Bright-field microscope
2. Dark –field microscope
3. Phase-contrast microscope
4. Fluorescence microscopes

These are compound microscopes as image is formed by action of two or more than lenses.

### **1. The Bright –Field Microscope**

This microscope produces a dark image against a brighter background. There are several objective lenses are present in the microscope.

Total magnification is the product of the magnifications of the ocular lens and the objective lens.

Microscope Resolution is the ability of a lens to separate or distinguish small objects that are close together. Wavelength of light used is a major factor in the resolution. As we have discussed earlier that if we use shorter wavelength, there will be greater resolution.

**Table 1: The properties of microscope objectives**

Property	Scanning	Objective		
		Low power	High power	oil Immersion
Magnification	4x	10x	40-45x	90-100x
Numerical aperture	0.10	0.25	0.55-0.65	1.25-1.4
Approximate focal length( $f$ )	40mm	16mm	4mm	1.8-2.0mm
Working distance	17-20mm	4-8mm	0.5-.7mm	0.1mm
Approximate resolving Power with light of 450nm (blue light)	2.3um	0.9um	0.35um	0.18um

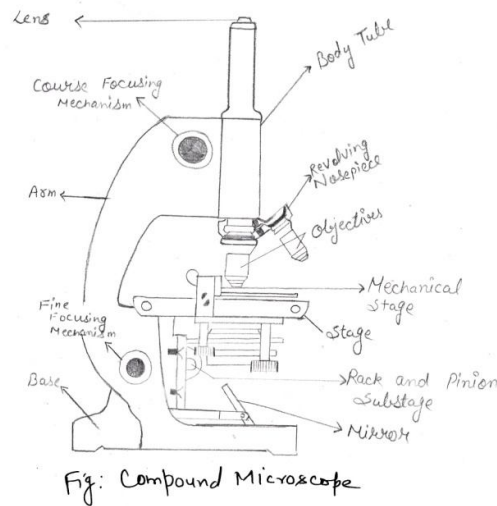

## **1. The Dark-Field Microscope**

This microscope produces a bright image of the object against a dark background. It is used to observe living, unstained preparations.

## **1. The Phase-Contrast microscope**

It enhances the contrast between intracellular structures having slight differences in refractive index. This microscope is excellently used to observe living cells.

### **Working of Phase –Contrast Microscope:**

In microscopy there is a small phase shifts in the light passing through a transparent specimen are converted into amplitude or contrast changes in the image. A phase contrast microscope does not require staining to view the object as it is used to study living cells. This microscope made it possible to study the cell cycle very comfortably.

As light travels through a medium other than vacuum, it causes its amplitude and phase to change in a way which depends on properties of the medium. This change in amplitude give rise to familiar absorption of light which gives rise to colours as it is wavelength dependent. Our eye measures only the energy of light arriving on the retina, so changes in phase are not easily observed, yet often these changes in phase carry a large amount of information.

To make phase variations observable, it is necessary to combine the light passing through the sample with a reference so that the resulting interference reveals the phase structure of the sample; same is done using Phase-contrast microscope. Frits Zernike is given credit of discovering the Phase-Contrast Microscope. He was awarded the Nobel Prize (physics) in 1953.

In this microscopy, the necessary phase change is introduced by rings etched accurately onto glass plates so that they introduce the required phase change when inserted into the optical path of the microscope during study. This technique allows phase of the light passing through the object under study to be inferred from the intensity of the image produced by the microscope.

A phase ring is responsible cover the phase change, which is located in a conjugated aperture plane somewhere behind the front lens element of the objective and a matching annular ring, which is located in the primary aperture plane; this is the location of the condenser's aperture.

Two selected light rays, which are emitted from the light source, get focused by the lens inside the opening of the condenser annular ring. These two light rays are then refracted in such way that they exit the condenser lens as parallel rays.

We may assume that the two rays in question are neither refracted nor diffracted in the specimen plane, they enter the objective as parallel rays. Since all parallel rays are focused in the back focal plane of the objective, the back focal plane is a conjugated aperture plane to the condenser's front focal plane; this is the location of the condenser annulus. To complete the phase setup, a phase plate is positioned inside the back focal plane in such a way that it lines up nicely with the condenser annulus.

You must know that phase-shift of  $90^\circ$  ( $\lambda/4$ ) due to objects are balanced again  $90^\circ$  ( $\lambda/4$ ) by phase plates. The recombination of these two waves in the primary image plane results in a significant amplitude change at all locations where there is a now destructive interference due to a  $180^\circ$  ( $\lambda/2$ ) phase shift. The net phase shift of  $180^\circ$  ( $\lambda/2$ ) results directly from the  $90^\circ$  ( $\lambda/4$ ) retardation of the phase object and the  $90^\circ$  ( $\lambda/4$ ) phase advancement of the wave due to the phase plate.

The Differential interference Contrast Microscope creates image by detecting differences in refractive indices and thickness of different parts of specimen.

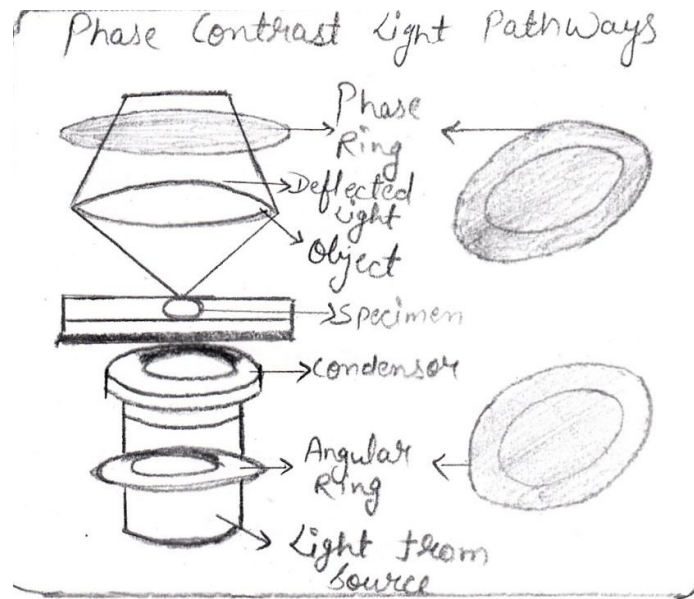

Phase Contrast Microscope

## 2. The Fluorescence Microscope

This microscopy exposes specimen to ultraviolet violet, or blue light. Specimens usually stained with fluorochromes, which emits fluorescent light



while exposed against light. It results in a bright image of the object resulting from the fluorescent light emitted by the specimen.

### Working of the Fluorescence Microscope

Barrier filter are there in this microscopy which removes any remaining exciter wavelengths (up to about 500nm) without absorbing longer wavelengths of fluorescing object. As told already that specimen stained with fluorochrome emits fluorescence when activated by wavelength of light; especially dark-field condenser provides dark background for fluorescence.

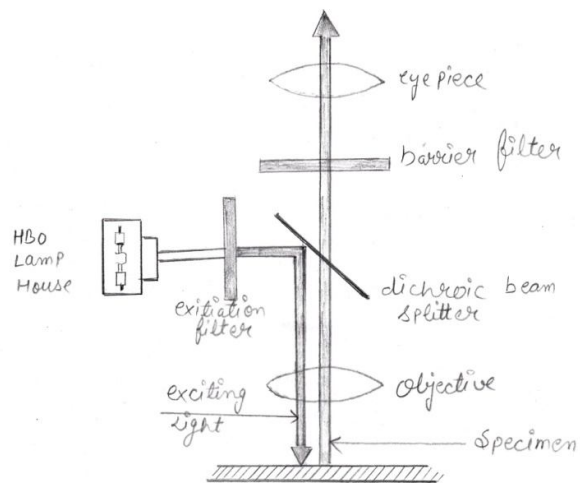

Fig: Fluorescent Microscope

### 3. Polarized Light Microscopy

Basic principles of polarized light

You must have read in 10+2 physics class that ordinary light contains light waves that vibrate in a direction perpendicular to its direction of travel. Especially, Polarized light is used only as a means of rendering microstructures visible in non-cubic metals or polymers. For generating polarized light, ordinary light must pass or be reflected by a polarizing device. This device will absorb all directions of vibration except the permitted direction. This light emerging from the interaction called polarized light. Polarized light not only elucidates identifying parameters, it often detects delicate changes also.

Polarized light is known for two distinct phenomenons: 1. the nature of the incoming light and 2. the internal characteristic of the material. Polarized light enhances contrast based on the difference in refractive indices in at least two

directions in a material used. For example, a drawn fiber will have two refractive indices: first along its length and second across its diameter.

In polarized microscope, amorphous and crystalline regions in a polymer will respond to polarized light through interference. If we use the dark field setting on the cross polarizer, the amorphous part of the polymer is optically transparent and will appear tan in the image while the light passing through the crystalline regions will appear white. It occurs because the crystals lie along the transmission axis of the light.

Again during the study of light field measurements, the crystalline regions will react with destructive interference with the light while the amorphous regions will react as before with the light. These two phenomena are responsible for image formation in Polarized Light Microscopy.

#### **4. UV Light Microscopy**

Application of light beam with a shorter wavelength using UV light is also possible resulting in higher resolving power. Using UV light the resolution can be reduced to 0.1  $\mu\text{m}$ , but special quartz lenses and UV-light detector are essential, so that the light microscope with UV light source is only a theoretical possibility.

#### **7. Classical Interference Microscopy**

In this microscopy there is use of two separate light beams with much greater lateral separation than that used in phase contrast microscopy.

Due to use of two beams the interference microscope is having special features where object and reference beam pass through the same objective, two images are produced of every object (one being the "ghost image"). These two images are separated either laterally within the visual field or at different focal planes. These two images can be overlapping sometimes, since they can severely affect the accuracy of mass thickness measurements. Rotation of the preparation is used to avoid this problem.

The main advantage of interference microscopy measurements is to explore measuring the projected dry mass of living cells, which was first effectively exploited by Andrew Huxley in studies of striated muscle cell structure and function, leading to the sliding filament model of muscle contraction.

---

## **1.3 Electron microscopy**

---

In electron microscopy, beams of electrons are used to produce images. As we already know that wavelength of electron beam is much shorter than light, resulting in much higher resolution. Generally, two types of electron microscopy is used to study the very minute objects-

### **1. The Transmission Electron Microscope (TEM)**

We have studied in earlier classes that electrons scatter when they pass through thin sections of a specimen.

Transmitted electrons (those that do not scatter) are used in this microscopy to produce image where denser regions in specimen, scatter more electrons and appear darker.

### **2 The Scanning Electron Microscope(SEM)**

As already discussed that electrons scatter when they pass through thin sections of a specimen. Scattered electrons produce image of thin sections in this microscopy.

#### **Working of SEM**

In SEM, the electron beam comes from a filament, made of various types of materials. For this purpose, the most commonly the Tungsten gun is used. The filament is a loop of tungsten which works as the cathode. A voltage is applied to the loop, causing it to heat or warm up. Again there is a anode, which is positive with respect to the filament, responsible for attractive forces for electrons.

It is an important phenomenon here that electrons accelerate toward the anode. They accelerate right by the anode and hit the sample through column.

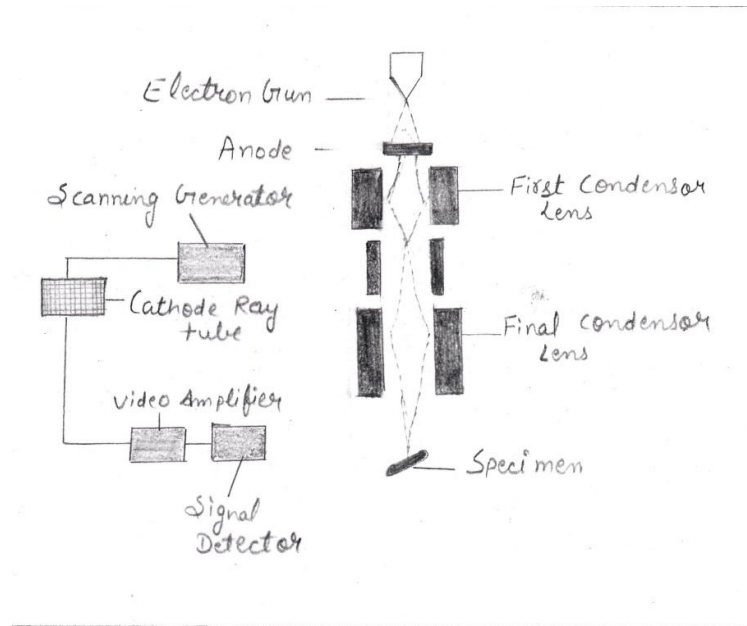

Fig: Electron Microscope

### Specimen preparation in Electron Microscopy

In Electron Microscopy different procedures used than light microscopy.

In transmission electron microscopy, specimens should be cut very thin as specimens are chemically fixed and stained with electron dense material.

Other preparation methods like (i) Shadowing where coating of specimen with a thin film of a heavy metal is done.

(ii) Freeze-etching where specimen are Freeze then fracture along lines of greatest weakness (e.g. Membranes).

In Scanning Electron Microscope electrons are reflected from the surface of a specimen to create image and it produces a 3-dimensional image of specimen's surface features.

---

## 1.4 Atomic Force Microscopy

---

Atomic force microscopy (AFM) is also called scanning force microscopy (SFM) is a very high-resolution type of scanning probe microscopy. This works more than 1000 times better than the optical diffraction limit. The lower version of AFM, the scanning tunneling microscope, was developed by Gerd Binnig and Heinrich Rohrer in the early 1980s at IBM Research – Zurich. This development got the Nobel Prize for Physics in 1986.

The first atomic force microscope was introduced in 1989 for commercial purpose. This is one of the foremost tools for imaging, measuring, and

manipulating matter at the nano-scale. The information is gathered by studying the surface with a mechanical probe. Piezoelectric elements that facilitate small but accurate and precise movements on (electronic) command are responsible for very precise scanning.

In this microscopy, sharp probe moves over surface of specimen at constant distance. There is up and down movement of probe as it maintains constant distance is detected and used to create image.

---

## **1.5 Summary**

---

In compound microscopes there is combined effect of two or more than two lenses where as generally one lens is used to enlarge the object in dissecting microscopes. Different types of microscopes are there on the basis of source i.e. light, electrons or atomic force.

---

## **1.6 Self Learning Exercises**

---

### **Section A (Very Short Answer Type)**

1. Who studied first small microorganisms using microscope ?
2. Who got nobel prize for developing Phase Contrast Microscope ?

### **Section B ( Short Answer Type)**

1. What is refractive Index ?
2. What is role of lences in microscopes ?
3. What is principle of electron microscopy ?

### **Section C ( Long Answer Type)**

1. Describe Phase Contrast Microscopy?
2. Write a note on Electron Microscopy ?
3. Draw well labeled diagram of a light compound microscope.

### **Answer to Very Short Answer type Questions**

1. Antony Von Leuwenhock 2. Frits Zernike

---

## **1.7 Reference**

---

- Molecular Biology of Cell, Alberts B et al. Garland Publishers, (2001)
- Molecular Cell Biology, Lodish et al. Scientific American Books (1995)
- [www.researchgate.net](http://www.researchgate.net)

## Unit - 2

---

# **Cytological techniques: Staining techniques ,isolation and fractionation of cell , Cell Culture,. Centrifugation and Ultracentrifugation, Electrophoresis, Chromatography, Cytometry**

---

### **Structure of the Unit**

- 2.0 Objectives
- 2.1 Introduction
- 2.2 Cell staining
  - 2.2.1 Types of staining
    - 2.2.1.1 Simple staining technique
    - 2.2.1.2 Differential staining technique
  - 2.2.2 Some biological stains
- 2.3 Cell isolation and fractionation
  - 2.3.1 Homogenization
  - 2.3.2 Homogenization techniques
  - 2.3.3 Fractionation
  - 2.3.4 Physical Properties of Biological Materials
- 2.4 Centrifugation and Ultracentrifugation
  - 2.4.1 Centrifugation
  - 2.4.2 Differential centrifugation
  - 2.4.3 Equilibrium density-gradient centrifugation
- 2.5 Electrophoresis
  - 2.5.1 Physical basis
  - 2.5.2 Gel conditions
  - 2.5.3 Visualizations

- 2.5.4 Applications
- 2.6 Chromatography
  - 2.6.1.1 Column chromatography
  - 2.6.1.2 Planar chromatography
  - 2.6.1.3 Paper chromatography
  - 2.6.1.4 Thin layer chromatography
  - 2.6.2 Types of techniques on the basis of physical state of mobile phase
    - 2.6.2.1 Gas chromatography
    - 2.6.2.2 Liquid chromatography
  - 2.6.3 Specific chromatographic techniques
    - 2.6.3.1 Affinity chromatography
    - 2.6.3.2 Supercritical fluid chromatography
  - 2.6.4 Techniques on the basis of separation mechanism
    - 2.6.4.1 Ion exchange chromatography
    - 2.6.4.2 Size-exclusion chromatography
- 2.7 Cytometry
  - 2.7.1 Image cytometer
  - 2.7.2 Flow cytometers
  - 2.7.3 Time-lapse cytometers
- 2.8 Summary

---

## **2.0 Objectives**

---

After going through this unit you will be able to understand

- Application and functioning of cytological technique.
- About the process of cell isolation and fractionation.
- Electro-phoresis techniques for DNA and protein separation.
- Different types of chromatographic methods.
- Centrifugation methods and their applications.

---

## 2.1 Introduction

---

Cytological techniques are methods used in the study or manipulation of cells. These include methods used in cell biology to culture, track, phenotype, sort and screen cells in populations or tissues, and molecular methods to understand cellular function.

Wonderful advances are being made in various other branches of cytology.

1. Perhaps the most striking is the actual isolation of mitochondria and other cell-constituents, a technique that we owe to the pioneer work of Bensley and Hoerr (1934).
2. Old techniques introduced by Raspail in 1829 and Altmann in 1890 have been revived to give us micro-incineration and the freezing-drying method once more.
3. Micro-manipulation enables us literally to probe the living cell.
4. Histochemistry has made great advances: enzymes have actually been made to reveal their presence by their action in sections.
5. ultra-violet spectrophotometry has taught us much about the distribution of nucleoproteins in cells.
6. The electron microscope makes us hope for still minute knowledge of cellular structure, while X-rays are revealing details of the structure of proteins far beyond anything that the ordinary microscope can detect.

The living cell of multi-cellular animals is very difficult to study, for several reasons. It is usually not possible to separate it from other cells without the help of various substances that kill it, and unless we separate it, we cannot get a good view of it. If we choose a cell which we can observe closely while still alive, we are still confronted with the difficulty that its contents are mostly colourless and transparent, and only distinguishable from one another, if at light. The cytoplasmic substances are invisible on ordinary microscopic examination of the living cell. The methods of colloid chemistry and of X-ray and ultra-violet analysis, together with differential centrifuging and the freezing-drying technique of Gersh (1932) and his associates, have been necessary to disclose them.

---

## 2.2 Cell staining

---

Staining is an auxiliary technique used in microscopy to enhance contrast in the microscopic image. Stains and dyes are frequently used in biology and medicine to highlight structures in biological tissues for viewing,



often with the aid of different microscopes. Stains may be used to define and examine bulk tissues (highlighting, for example, muscle fibers or connective tissue), cell populations (classifying different blood cells, for instance), or organelles within individual cells. Cell staining is a technique used for the main purpose of increasing contrast through changing the color of some of the parts of the structure being observed thus allowing for a clearer view. There are a variety of microscopic stains that can be used in microscopy. First of all, staining can be in-vivo or in-vitro. The difference between these is that whereas In-vivo staining refers to the staining of a biological matter while it is still alive, in-vitro staining refers to a staining technique where the biological matter is non-living.

### **Stainability of tissue**

Tissues which take up stains are called chromatic. Chromosomes were so named because of their ability to absorb a violet stain.

Positive affinity for a specific stain may be designated by the suffix *-philic*. For example, tissues that stain with an azure stain may be referred to as azurophilic. This may also be used for more generalized staining properties, such as acidophilic for tissues that stain by acidic stains (most notably eosin), basophilic when staining in basic dyes, and *amphophilic* when staining with either acid or basic dyes. In contrast, chromophobic tissues do not take up coloured dye readily.

#### **2.2.1 Types of staining**

##### **2.2.1.1 -Simple stain techniques**

Staining can be performed with basic dyes such as crystal violet or methylene blue, positively charged dyes that are attracted to the negatively charged materials of the microbial cytoplasm. Such a procedure is the simple stain procedure. An alternative is to use a dye such as nigrosin or Congo red, acidic, negatively charged dyes. They are repelled by the negatively charged cytoplasm and gather around the cells, leaving the cells clear and unstained. This technique is called the negative stain technique.

##### **2.2.1.2 - Differential stain techniques**

The differential stain technique distinguishes two kinds of organisms.

#### **i. Gram stain technique**

This differential technique separates bacteria into two groups, Gram-positive bacteria and Gram-negative bacteria. Crystal violet is first applied, followed by

the mordant iodine, which fixes the stain (Figure ). Then the slide is washed with alcohol, and the Gram-positive bacteria retain the crystal-violet iodine stain; however, the Gram-negative bacteria lose the stain. The Gram-negative bacteria subsequently stain with the safranin dye, the counterstain, used next. These bacteria appear red under the oil-immersion lens, while Gram-positive bacteria appear blue or purple, reflecting the crystal violet retained during the washing step.

ii. **Acid-fast technique.**

This technique differentiates species of *Mycobacterium* from other bacteria. Heat or a lipid solvent is used to carry the first stain, carbolfuchsin, into the cells. Then the cells are washed with a dilute acid-alcohol solution. *Mycobacterium* species resist the effect of the acid-alcohol and retain the carbolfuchsin stain (bright red). Other bacteria lose the stain and take on the subsequent methylene blue stain (blue). Thus, the acid-fast bacteria appear bright red, while the nonacid-fast bacteria appear blue when observed under oil-immersion microscopy.

iii. **Other stain techniques**

Seek to identify various bacterial structures of importance. For instance, a special stain technique highlights the flagella of bacteria by coating the flagella with dyes or metals to increase their width. Flagella so stained can then be observed.

iv. **Malachite green technique**

A special stain technique is used to examine bacterial spores. Malachite green is used with heat to force the stain into the cells and give them color. A counterstained, safranin, is then used to give color to the non-spore forming bacteria. At the end of the procedure, spores stain green and other cells stain red.

2.2.2 **Some biological stains**

**Acridine orange**

Acridine orange (AO) is a nucleic acid selective fluorescent cationic dye useful for cell cycle determination. It is cell-permeable, and interacts with DNA and RNA by intercalation or electrostatic attractions. When bound to DNA, it is very similar spectrally to fluorescein. Like fluorescein, it is also useful as a non-

specific stain for backlighting conventionally stained cells on the surface of a solid sample of tissue.

### **Carmines**

Carmines are intensely red dyes used to stain glycogen, while Carmines alum is a nuclear stain. Carmines stains require the use of a mordant, usually aluminum.

### **Coomassie blue**

Coomassie blue (also brilliant blue) nonspecifically stains proteins a strong blue colour. It is often used in gel electrophoresis.

### **Cresyl violet**

Cresyl violet stains the acidic components of the neuronal cytoplasm a violet colour, specifically Nissl bodies. Often used in brain research.

### **Crystal violet**

Crystal violet, when combined with a suitable mordant, stains cell walls purple. Crystal violet is the stain used in Gram staining.

### **DAPI**

DAPI is a fluorescent nuclear stain, excited by ultraviolet light and showing strong blue fluorescence when bound to DNA. DAPI binds with A=T rich repeats of chromosomes. DAPI is also not visible with regular transmission microscopy. It may be used in living or fixed cells. DAPI-stained cells are especially appropriate for cell counting.[6]

### **Eosin**

Eosin is most often used as a counterstain to haematoxylin, imparting a pink or red colour to cytoplasmic material, cell membranes, and some extracellular structures. It also imparts a strong red colour to red blood cells. Eosin may also be used as a counterstain in some variants of Gram staining, and in many other protocols.

### **Ethidium bromide**

Ethidium bromide intercalates and stains DNA, providing a fluorescent red-orange stain. Although it will not stain healthy cells, it can be used to identify cells that are in the final stages of apoptosis – such cells have much more permeable membranes. Consequently, ethidium bromide is often used as a marker for apoptosis in cells populations and to locate bands of DNA in gel electrophoresis. The stain may also be used in conjunction with acridine orange (AO) in viable cell counting. This EB/AO combined stain causes live cells to fluoresce green whilst apoptotic cells retain the distinctive red-orange fluorescence.

### **Acid fuchsin**

Acid fuchsin may be used to stain collagen, smooth muscle, or mitochondria. Acid fuchsin is used as the nuclear and cytoplasmic stain in Mallory's trichrome method. Acid fuchsin stains cytoplasm in some variants of Masson's trichrome. In Van Gieson's picro-fuchsin, acid fuchsin imparts its red colour to collagen fibres. Acid fuchsin is also a traditional stain for mitochondria (Altmann's method).

### **Haematoxylin**

Haematoxylin (hematoxylin in North America) is a nuclear stain. Used with a mordant, haematoxylin stains nuclei blue-violet or brown. It is most often used with eosin in H&E (haematoxylin and eosin) staining—one of the most common procedures in histology.

### **Hoechst stains**

Hoechst is a *bis*-benzimidazole derivative compound that binds to the *minor groove* of DNA. Often used in fluorescence microscopy for DNA staining, Hoechst stains appear yellow when dissolved in aqueous solutions and emit blue light under UV excitation. There are two major types of Hoechst: *Hoechst 33258* and *Hoechst 33342*. The two compounds are functionally similar, but with a little difference in structure. Hoechst 33258 contains a terminal hydroxyl group and is thus more soluble in aqueous solution, however this characteristic reduces its ability to penetrate the plasma membrane. Hoechst 33342 contains an ethyl substitution on the terminal hydroxyl group (i.e. an ethylether group) making it more hydrophobic for easier plasma membrane passage

## **Iodine**

Iodine is used in chemistry as an indicator for starch. When starch is mixed with iodine in solution, an intensely dark blue colour develops, representing a starch/iodine complex. Starch is a substance common to most plant cells and so a weak iodine solution will stain starch present in the cells. Iodine is one component in the staining technique known as Gram staining, used in microbiology. Lugol's solution or Lugol's iodine (IKI) is a brown solution that turns black in the presence of starches and can be used as a cell stain, making the cell nuclei more visible. Iodine is also used as a mordant in Gram's staining, it enhances dye to enter through the pore present in the cell wall/membrane.

## **Malachite green**

Malachite green (also known as diamond green B or victoria green B) can be used as a blue-green counterstain to safranin in the Gimenez staining technique for bacteria. It also can be used to directly stain spores.

## **Safranin**

Safranin (or Safranin O) is a nuclear stain. It produces red nuclei, and is used primarily as a counterstain. Safranin may also be used to give a yellow colour to collagen.

---

## **2.3 Isolation and fractionation of cell**

---

The basic principle for all microscopes is that the cell is composed of smaller physical units, the organelles. Definition of the organelles is possible with microscopy, but the function of individual organelles is often beyond the ability of observations through a microscope. We are able to increase our chemical knowledge of organelle function by isolating organelles into reasonably pure fractions.

A host of fractionation procedures are employed by cell biologists. Each organelle has characteristics (size, shape and density for example) which make it different from other organelles within the same cell. If the cell is broken open in a gentle manner, each of its organelles can be subsequently isolated. The process of breaking open cells is **homogenization** and the subsequent isolation of organelles is **fractionation**. Isolating the organelles requires the use of physical chemistry techniques, and those techniques can range from the use of simple sieves, gravity sedimentation or differential precipitation, to

ultracentrifugation of fluorescent labeled organelles in computer generated density gradients.

### **2.3.1 Homogenization**

Often, the first step in the preparation of isolated organelles is to obtain a "pure" sample for further analysis. Cells which are not attached to others (such as blood or suspension tissue cultures) can be separated if they have distinct shapes, densities or characteristics which can be marked (such as charge, antigen or enzyme presence). Cells which are part of a more solid tissue (such as liver or kidney) will first need to be separated from all connections with other cells. In some cases this can be performed by simply chelating the environment (removing  $\text{Ca}^{++}$  and/or  $\text{Mg}^{++}$ ), but in most instances the cells will need to be enzymatically or mechanically disaggregated. This often results in subtle changes to the cells, and at a minimum will disrupt such cell-cell communications as DESMOSOMES and TIGHT JUNCTIONS.

Homogenization techniques can be divided into those brought about by osmotic alteration of the media which cells are found in, or those which require physical force to disrupt cell structure. The physical means encompass use of mortars and pestles, blenders, compression and/or expansion, or ultrasonification.

### **2.3.2 Homogenization techniques**

#### *Osmotic alterations*

Many organelles are easier to separate if the cells are slightly swollen. The inhibition of water into a cell will cause osmotic swelling of the cell and/or organelle, which can often assist in the rupture of the cell and subsequent organelle separation. The use of a hypo-osmotic buffer can be very beneficial, for example, in the isolation of mitochondria and in the isolation of mitotic chromosomes.

#### *Mortars, Pestles*

Perhaps the most common procedures use Ten Broeck or Dounce homogenizers, both of which are glass mortar and pestle arrangements with manufactured, controlled bore sizes. The addition of a motor driven teflon pestle creates the Potter-Elvehjem homogenizer. Ultrasonification is a useful adjunct to this procedure, but is often sufficient by itself.

#### *Blenders*

For molecular separations, mechanical blenders are often used, varying in sophistication from household blenders to high speed blenders with specially

designed blades and chambers (e.g. a Virtis Tissue Homogenizer). The mechanical procedures are augmented by various organic solvents (for phase separations) and/or detergents to assist the denaturation and separation of molecules (e.g. DNA from histones). When specific molecules are sought, care must be taken to inhibit powerful degradation enzymes (such as RNase when extracting RNA). This can be accomplished by subjecting the specimen to cold temperature, or by adding specific organic inhibitors (Diethylpyrocarbonate for RNase), or both.

### ***Compression/Expansion***

For cellular material which is difficult to shear by the above mentioned techniques (plant cells and bacteria), a device known as a "French Press" is occasionally used. This device forces a slurry of the cells through an orifice (opening) at very high pressures. The rapid expansion of the pressure from within literally "blows" the cells apart. While this technique is not often required, it is the only way to break open some materials. The units have capacities from 1 to 40 ml and can reach pressures of 20,000-40,000 pounds per square inch (psi).

### ***Ultrasonification***

Ultrasonicators have been used with increasing popularity to separate organelles from cells, particularly from tissue culture cells. Light use of an ultrasonic wave can readily remove cells from a tissue culture substrate (such as the culture flask). It can also be adjusted to merely separate cells, or to break open the plasma membrane and leave the internal organelles intact.

## **2.3.3 Fractionation**

### ***Gravity Sedimentation***

Once the cells have been homogenized, the various components must be separated. For some materials (whole blood, cells in suspension), this can be accomplished by the simple use of gravity sedimentation. In this procedure, the samples are allowed to sit, and separation occurs due to the natural differences in size and shape (density) of the cells. Red blood cells are denser than white cells, and thus whole blood separates into an RBC-rich bottom layer, an intermediate "buffy coat" layer of WBC's and an upper plasma portion of settled blood samples (an anti-coagulant is added to prevent coagulation, which would interfere with the separation).

## ***Centrifugation***

Without question, however, the most widely used technique for fractionating cellular components is the use of centrifugal force. Procedures employing low speed instruments with greater volume capacity and refrigeration are known as "preparative" techniques. Analytical procedures, on the other hand, usually call for high speed with a corresponding lower volume capacity. A centrifuge working at speeds in excess of 20,000 RPM is an ultracentrifuge. Organelles may be separated in a centrifuge according to a number of basic procedures. They can be part of a moving boundary, a moving zone, a classical sedimentation equilibrium, a preformed gradient isodensity, an equilibrium isodensity or separated at an interface.

### **2.3.4 Physical Properties of Biological Materials**

Before undertaking the centrifugal separation of biological particles, let's discuss the particle behavior in a centrifugal force. Particles in suspension can be separated by either **sedimentation velocity**, or by **sedimentation equilibrium**. Sedimentation velocity is also known as **zone centrifugation** and has the advantage of low speed centrifugation and short times, but yields incomplete separations. Sedimentation equilibrium is also known as **isopycnic** or **density equilibration** and requires specimens to be subject to high speeds for prolonged periods of time. It has the advantage of separating particles completely.

---

## **2.4 Centrifugation and ultracentrifugation**

---

### **2.4.1 Centrifugation**

When an object attached to a rope is whirled around, one can feel that the rope must be pulled inward towards the centre of the rotation in order to keep the object on the orbit. This force prevents the object from getting away and move with a constant speed along a straight tangential line. The inward force with which one has to pull the rope is called the centripetal force. One can also define the outward force, the centrifugal force, by which the object pulls the rope. This force is equal in magnitude to the centripetal force but has the opposite direction. The centrifugal force ( $F_c$ ) is a virtual, so-called fictional force emerging due to the inertia of the object. Yet, because it leads to a simpler mathematical formalism, equations describing the processes when solutions are centrifuged use the  $F_c$  force.

According to the well-known Newton equation:



$$F = m \times a \quad (5.1)$$

Upon centrifugation, acceleration equals the product of the radius of the orbit and the square of the angular velocity:

$$a = \omega^2 \times r \quad (5.2)$$

The fictive centrifugal accelerating force in vacuum is therefore:

$$F_c = m \times \omega^2 \times r \quad (5.3)$$

The product of the radius and the square of the angular velocity equals the centrifugal accelerating potential. Traditionally, and perhaps somewhat misleadingly, the magnitude of this potential is compared to the Earth's gravitational accelerating potential ( $g$ ), and has been expressed in “ $g$ ” units. The reason is quite simple. Earth's gravitational potential, similarly to the accelerating potential provided by centrifugation, can also sediment particles dispersed in solution. This type of quantitation shows how many times centrifugation is more effective to sediment particles compared to the gravitational effect of Earth. In the fastest laboratory ultracentrifuges the applied accelerating potential can exceed 1 000 000  $g$ .

When solutions are centrifuged, the particles are not in vacuum but in a solvent having a given density (mass/volume). Importantly, the centrifugal force acts not only on the particles, but on the solvent too. If the density of the particle equals the density of the solvent, the particle will not move relative to the solvent, and its velocity along the radius will be zero. If the density of the particle exceeds that of the solvent, the particle sediments (sinks), i.e. it moves outwards along the radius, while the displaced solvent molecules move inwards. In the opposite case when the density of the particle is lower than that of the solvent, the particle floats—it moves inwards while the displaced solvent molecules move outwards.

#### **2.4.2 Differential centrifugation:**

The density of the various organelles differs on a smaller scale than their size. Therefore, while both size and density affect sedimentation velocity, their size difference dominates when organelles are separated by centrifugation.

In the procedure of differential centrifugation, cell constituents are separated from each other by their Svedberg value. Several consecutive centrifugation steps are applied in the order of increasing accelerating potential. Each

individual centrifugation step relies on the different sedimentation speed of the different cell constituents at the given acceleration potential. At a properly chosen acceleration potential, almost 100 % of the largest component will sediment in the time span of the centrifugation. The sedimented organelles form a pellet at the bottom of the centrifuge tube. The potential should be set so that in the same period of time only a small portion of all smaller constituents latch on to the pellet (Figure ).

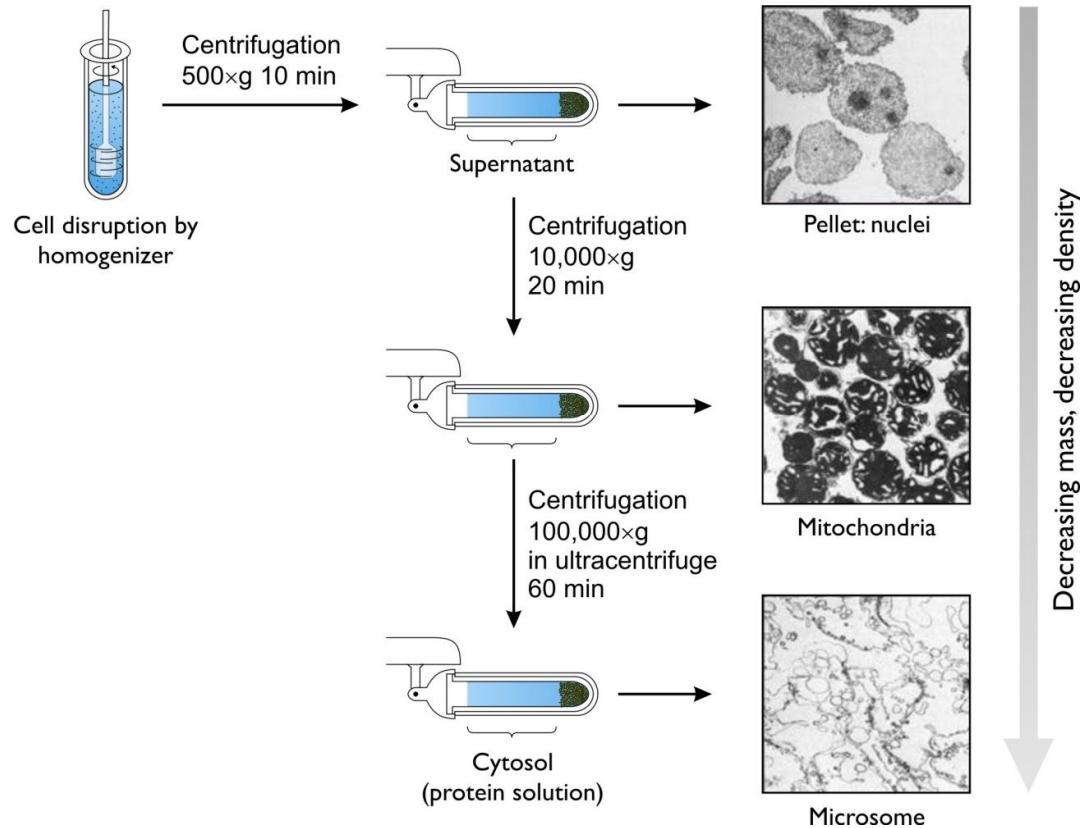

Figure- Differential centrifugation. In the course of differential centrifugation, consecutive centrifugation steps are applied. The consecutive centrifugation steps follow each other in the order of increasing centrifugal acceleration potential. During the first centrifugation, only the largest and/or heaviest cell constituents sediment in the time frame of the centrifugation. Typically, only nuclei and undisrupted whole cells form the pellet. The supernatant of the first centrifugation step is further centrifuged in the consecutive step at higher acceleration potential and typically for a longer period of time. Following this scheme, ever smaller and/or lower-density cell constituents can be sedimented.

The disrupted cell homogenate is centrifuged first at a relatively low accelerating potential of 500 g for 10 minutes. Under these conditions, only

particles having the highest Svedberg value, intact cells and nuclei will form the pellet. All other cell constituents will sediment at a much lower rate and remain in the homogenate. The supernatant of the first centrifugation is transferred into an empty centrifugation tube and is subjected to another centrifugation step, now at a significantly higher accelerating potential of 10,000 g and for 20 minutes. These conditions favour sedimentation of mitochondria, lysosomes and peroxisomes having lower Svedberg values than nuclei. Many cell constituents still remain in the supernatant, which is again transferred into an empty tube. This tube is placed into an ultracentrifuge and, with an accelerating potential of 100 000 g in one hour, the so-called microsomal fraction sediments. This fraction contains mostly artificial vesicles with a diameter of 50-150 nm that originate mostly from the endoplasmic reticulum and are generated by the cell disruption procedure. Other natural cell constituents of the same size range will also contribute to this fraction. After this third centrifugation step, the supernatant contains mostly macromolecules and supramolecular complexes such as ribosomes. By applying an accelerating potential as high as several hundred thousand g, ribosomes and large proteins can also be sedimented.

### 2.4.3 Equilibrium density-gradient centrifugation

The essence of equilibrium density-gradient centrifugation is principally different. In this case, a rather steep density gradient is created in the medium—in such a manner that the density of the medium gradually increases towards the bottom of the centrifuge tube. This is achieved by using a very high-density additive, for example caesium chloride (CsCl). The density gradient is created as follows. When the centrifuge tube is filled with the medium, a high concentration CsCl solution is added first. Subsequently, in the process of filling the tube, the concentration of CsCl is gradually decreased resulting in a CsCl gradient and, as a consequence, a density gradient in the tube. The sample is layered on the top of this special medium (Figure 5.2).

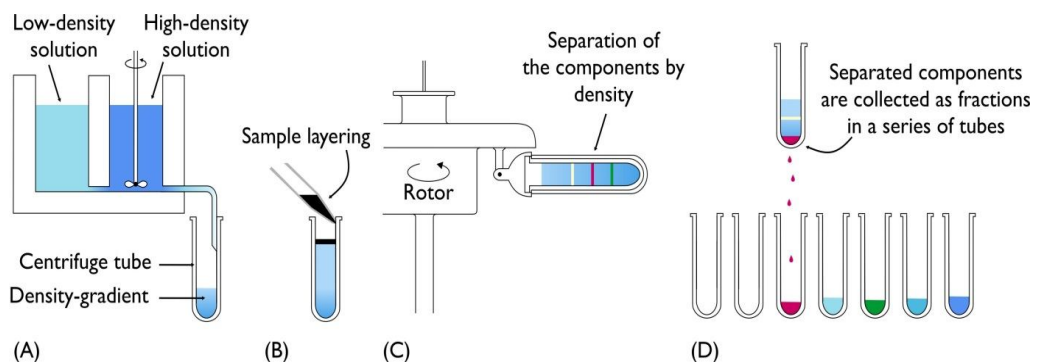

**Figure- Equilibrium density-gradient centrifugation.** In the course of equilibrium density-gradient centrifugation, a concentration gradient of a high density compound such as caesium chloride is generated. (The compound should not react with the biological sample.) The concentration gradient of this special additive creates a density gradient in the centrifuge tube. The density gradually increases toward the bottom of the centrifuge tube. The sample is layered on the low-density top of this gradient. As the centrifugation begins, each compound of the sample starts to sediment. By doing so, the compounds travel through layers of increasing density. As soon as a compound reaches the layer where the density equals its own density, the compound stops sedimenting. At this layer, no resultant force is exerted on the particle and thus it will float. As a result, equilibrium density-gradient centrifugation separates compounds from each other independently of their size, solely by their density, in a single run.

In the course of centrifugation, particles start to sediment moving towards the bottom of the centrifuge tube. By doing so, they travel through an increasing density medium. Each particle sediments to a section of the medium where its own density equals the density of the medium. At this section, the buoyancy factor becomes zero and, as a consequence, the accelerating force acting on the particle also becomes zero. The particle stops sedimenting. If it moved further towards the bottom of the tube, it would meet a higher density medium and a force opposing to its moving direction would be exerted on it, turning the particle back. If, by travelling backwards, it would meet a density lower than its own density, it would sediment again. As a consequence, this method separates particles exclusively based on their density. It is an equilibrium method in which, by the end of the separation, the system reaches a constant state.

Note that the two centrifugation approaches introduced above separate particles by partially different characteristics. Consecutive combination of the two methods can lead to a more efficient separation than achieved by any of the methods alone. Therefore, to increase separation efficiency, fractions generated by differential centrifugation can be subjected to a subsequent density-gradient centrifugation step to further separate individual components (Figure).

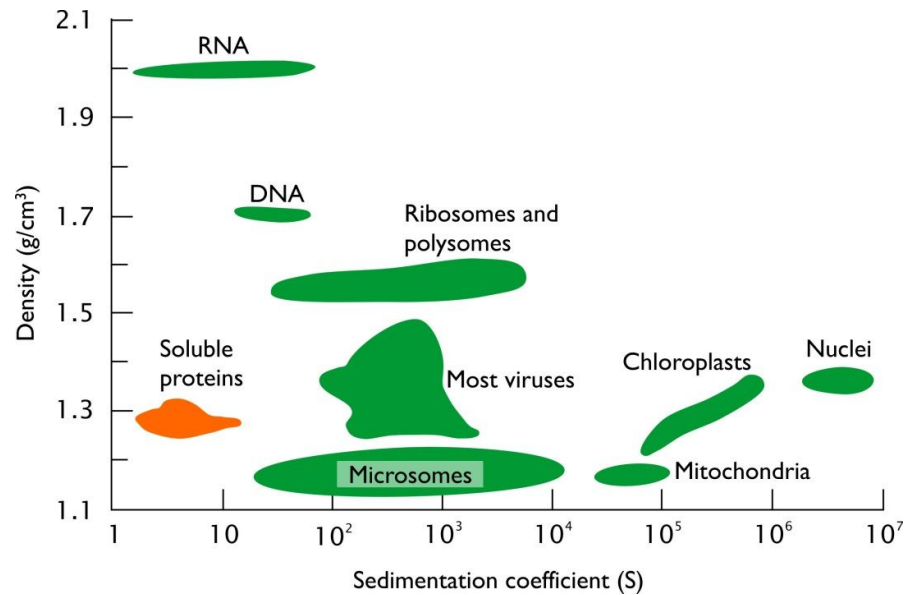

Figure- Combination of differential centrifugation and density-gradient centrifugation. Differential centrifugation separates compounds primarily based on their size, while density-gradient centrifugation separates compounds exclusively based on their density. Compounds that have different density but sediment in the same fraction during differential centrifugation can be separated by a subsequent step of density-gradient centrifugation. Two such consecutive steps of the two centrifugation methods can provide significantly higher separation efficiency than either procedure alone.

---

## 2.5 Electrophoresis

---

**Electrophoresis** is the motion of dispersed particles relative to a fluid under the influence of a spatially uniform electric field.<sup>[1][2][3][4][5][6]</sup> This electrokinetic phenomenon was observed for the first time in 1807 by Ferdinand Frederic Reuss (Moscow State University),<sup>[7]</sup> who noticed that the application of a constant electric field caused clay particles dispersed in water to migrate. It is ultimately caused by the presence of a charged interface between the particle surface and the surrounding fluid. It is the basis for a number of analytical techniques used in biochemistry for separating molecules by size, charge, or binding affinity.

Electrophoresis of positively charged particles (cations) is called **cataphoresis**, while electrophoresis of negatively charged particles (anions) is called **anaphoresis**. Electrophoresis is a technique used in laboratories in order to separate macromolecules based on size. The technique applies a negative charge so proteins move towards a positive charge. This is used for both DNA

and RNA analysis. Polyacrylamide gel electrophoresis (PAGE) has a clearer resolution than agarose and is more suitable for quantitative analysis. In this technique DNA footprinting can identify how proteins bind to DNA. It can be used to separate proteins by size, density and purity. It can also be used for plasmid analysis, which develops our understanding of bacteria becoming resistant to antibiotics.

**Gel electrophoresis** is a method for separation and analysis of macromolecules (DNA, RNA and proteins) and their fragments, based on their size and charge. It is used in clinical chemistry to separate proteins by charge and/or size (IEF agarose, essentially size independent) and in biochemistry and molecular biology to separate a mixed population of DNA and RNA fragments by length, to estimate the size of DNA and RNA fragments or to separate proteins by charge. Nucleic acid molecules are separated by applying an electric field to move the negatively charged molecules through a matrix of agarose or other substances. Shorter molecules move faster and migrate farther than longer ones because shorter molecules migrate more easily through the pores of the gel. This phenomenon is called sieving.<sup>[2]</sup> Proteins are separated by charge in agarose because the pores of the gel are too large to sieve proteins. Gel electrophoresis can also be used for separation of nanoparticles.

Gel electrophoresis uses a gel as an anticonvective medium and/or sieving medium during electrophoresis, the movement of a charged particle in an electrical field. Gels suppress the thermal convection caused by application of the electric field, and can also act as a sieving medium, retarding the passage of molecules; gels can also simply serve to maintain the finished separation, so that a post electrophoresis stain can be applied.<sup>[3]</sup> DNA Gel electrophoresis is usually performed for analytical purposes, often after amplification of DNA via PCR, but may be used as a preparative technique prior to use of other methods such as mass spectrometry, RFLP, PCR, cloning, DNA sequencing, or Southern blotting for further characterization.

### **2.5.1 Physical basis**

In simple terms, electrophoresis is a process which enables the sorting of molecules based on size. Using an electric field, molecules (such as DNA) can be made to move through a gel made of agar or polyacrylamide. The electric field consists of a negative charge at one end which pushes the molecules through the gel, and a positive charge at the other end that pulls the molecules through the gel. The molecules being sorted are dispensed into a well in the gel

material. The gel is placed in an electrophoresis chamber, which is then connected to a power source. When the electric current is applied, the larger molecules move more slowly through the gel while the smaller molecules move faster. The different sized molecules form distinct bands on the gel.

The term "gel" in this instance refers to the matrix used to contain, then separate the target molecules. In most cases, the gel is a crosslinked polymer whose composition and porosity is chosen based on the specific weight and composition of the target to be analyzed. When separating proteins or small nucleic acids (DNA, RNA, or oligonucleotides) the gel is usually composed of different concentrations of acrylamide and a cross-linker, producing different sized mesh networks of polyacrylamide. When separating larger nucleic acids (greater than a few hundred bases), the preferred matrix is purified agarose. In both cases, the gel forms a solid, yet porous matrix. Acrylamide, in contrast to polyacrylamide, is a neurotoxin and must be handled using appropriate safety precautions to avoid poisoning. Agarose is composed of long unbranched chains of uncharged carbohydrate without cross links resulting in a gel with large pores allowing for the separation of macromolecules

"Electrophoresis" refers to the electromotive force (EMF) that is used to move the molecules through the gel matrix. By placing the molecules in wells in the gel and applying an electric field, the molecules will move through the matrix at different rates, determined largely by their mass when the charge to mass ratio ( $Z$ ) of all species is uniform. However when charges are not all uniform then, the electrical field generated by the electrophoresis procedure will affect the species that have different charges and therefore will attract the species according to their charges being the opposite. Species that are positively charged (cations) will migrate towards the cathode which is negatively charged. If the species are negatively charged (anions) they will migrate towards the positively charged anode.<sup>[4]</sup>

If several samples have been loaded into adjacent wells in the gel, they will run parallel in individual lanes. Depending on the number of different molecules, each lane shows separation of the components from the original mixture as one or more distinct bands, one band per component. Incomplete separation of the components can lead to overlapping bands, or to indistinguishable smears representing multiple unresolved components. Bands in different lanes that end up at the same distance from the top contain molecules that passed through the gel with the same speed, which usually means they are approximately the same

size. There are molecular weight size markers available that contain a mixture of molecules of known sizes. If such a marker was run on one lane in the gel parallel to the unknown samples, the bands observed can be compared to those of the unknown in order to determine their size. The distance a band travels is approximately inversely proportional to the logarithm of the size of the molecule.

There are limits to electrophoretic techniques. Since passing current through a gel causes heating, gels may melt during electrophoresis. Electrophoresis is performed in buffer solutions to reduce pH changes due to the electric field, which is important because the charge of DNA and RNA depends on pH, but running for too long can exhaust the buffering capacity of the solution. Further, different preparations of genetic material may not migrate consistently with each other, for morphological or other reasons.

### **2.5.2 Gel conditions**

#### **Denaturing**

Denaturing gels are run under conditions that disrupt the natural structure of the analyte, causing it to unfold into a linear chain. Thus, the mobility of each macromolecule depends only on its linear length and its mass-to-charge ratio. Thus, the secondary, tertiary, and quaternary levels of biomolecular structure are disrupted, leaving only the primary structure to be analyzed.

Nucleic acids are often denatured by including urea in the buffer, while proteins are denatured using sodium dodecyl sulfate, usually as part of the SDS-PAGE process. For full denaturation of proteins, it is also necessary to reduce the covalent disulfide bonds that stabilize their tertiary and quaternary structure, a method called reducing PAGE. Reducing conditions are usually maintained by the addition of beta-mercaptoethanol or dithiothreitol. For general analysis of protein samples, reducing PAGE is the most common form of protein electrophoresis.

Denaturing conditions are necessary for proper estimation of molecular weight of RNA. RNA is able to form more intramolecular interactions than DNA which may result in change of its electrophoretic mobility. Urea, DMSO and glyoxal are the most often used denaturing agents to disrupt RNA structure. Originally, highly toxic methylmercury hydroxide was often used in denaturing RNA electrophoresis,<sup>[12]</sup> but it may be method of choice for some samples.<sup>[13]</sup>



Denaturing gel electrophoresis is used in the DNA and RNA banding pattern-based methods DGGE (denaturing gradient gel electrophoresis),<sup>[14]</sup> TGGE (temperature gradient gel electrophoresis), and TTGE (temporal temperature gradient electrophoresis).<sup>[15]</sup>

Native gels are run in non-denaturing conditions, so that the analyte's natural structure is maintained. This allows the physical size of the folded or assembled complex to affect the mobility, allowing for analysis of all four levels of the biomolecular structure. For biological samples, detergents are used only to the extent that they are necessary to lyse lipid membranes in the cell. Complexes remain—for the most part—associated and folded as they would be in the cell. One downside, however, is that complexes may not separate cleanly or predictably, as it is difficult to predict how the molecule's shape and size will affect its mobility.

Unlike denaturing methods, native gel electrophoresis does not use a charged denaturing agent. The molecules being separated (usually proteins or nucleic acids) therefore differ not only in molecular mass and intrinsic charge, but also the cross-sectional area, and thus experience different electrophoretic forces dependent on the shape of the overall structure. For proteins, since they remain in the native state they may be visualised not only by general protein staining reagents but also by specific enzyme-linked staining.

Native gel electrophoresis is typically used in proteomics and metallomics.<sup>[17]</sup> However, native PAGE is also used to scan genes (DNA) for unknown mutations as in Single-strand conformation polymorphism.

### **Buffers**

Buffers in gel electrophoresis are used to provide ions that carry a current and to maintain the pH at a relatively constant value. There are a number of buffers used for electrophoresis. The most common being, for nucleic acids Tris/Acetate/EDTA (TAE), Tris/Borate/EDTA (TBE). Many other buffers have been proposed, e.g. lithium borate, which is almost never used, based on Pubmed citations (LB), iso electric histidine, pK matched goods buffers, etc.; in most cases the purported rationale is lower current (less heat) and or matched ion mobilities, which leads to longer buffer life. Borate is problematic; Borate can polymerize, and/or interact with cis diols such as those found in RNA. TAE has the lowest buffering capacity but provides the best resolution for larger

DNA. This means a lower voltage and more time, but a better product. LB is relatively new and is ineffective in resolving fragments larger than 5 kbp; However, with its low conductivity, a much higher voltage could be used (up to 35 V/cm), which means a shorter analysis time for routine electrophoresis. As low as one base pair size difference could be resolved in 3% agarose gel with an extremely low conductivity medium (1 mM Lithium borate).<sup>[18]</sup>

Most SDS-PAGE protein separations are performed using a "discontinuous" (or DISC) buffer system that significantly enhances the sharpness of the bands within the gel. During electrophoresis in a discontinuous gel system, an ion gradient is formed in the early stage of electrophoresis that causes all of the proteins to focus into a single sharp band in a process called isotachopheresis. Separation of the proteins by size is achieved in the lower, "resolving" region of the gel. The resolving gel typically has a much smaller pore size, which leads to a sieving effect that now determines the electrophoretic mobility of the proteins.

### 2.5.3 Visualization

After the electrophoresis is complete, the molecules in the gel can be stained to make them visible. DNA may be visualized using ethidium bromide which, when intercalated into DNA, fluoresce under ultraviolet light, while protein may be visualised using silver stain or Coomassie Brilliant Blue dye. Other methods may also be used to visualize the separation of the mixture's components on the gel. If the molecules to be separated contain radioactivity, for example in a DNA sequencing gel, an autoradiogram can be recorded of the gel. Photographs can be taken of gels, often using a Gel Doc system.

### 2.5.4 Application

- Estimation of the size of DNA molecules following restriction enzyme digestion, e.g. in restriction mapping of cloned DNA.
- Analysis of PCR products, e.g. in molecular genetic diagnosis or genetic fingerprinting
- Separation of restricted genomic DNA prior to Southern transfer, or of RNA prior to Northern transfer.

---

## 2.6 Chromatography

---

**Chromatography** is the collective term for a set of laboratory techniques for the separation of mixtures. The mixture is dissolved in a fluid called the *mobile phase*, which carries it through a structure holding another material called

the *stationary phase*. The various constituents of the mixture travel at different speeds, causing them to separate. The separation is based on differential partitioning between the mobile and stationary phases. Subtle differences in a compound's partition coefficient result in differential retention on the stationary phase and thus changing the separation.

Chromatography may be preparative or analytical. The purpose of preparative chromatography is to separate the components of a mixture for more advanced use (and is thus a form of purification). Analytical chromatography is done normally with smaller amounts of material and is for measuring the relative proportions of analytes in a mixture.

### **Terms relevant to chromatography**

- **Analyte** is the substance to be separated during chromatography. It is also normally what is needed from the mixture.
- A **bonded phase** is a stationary phase that is covalently bonded to the support particles or to the inside wall of the column tubing.
- A **chromatogram** is the visual output of the chromatograph. In the case of an optimal separation, different peaks or patterns on the chromatogram correspond to different components of the separated mixture.
- The **eluate** is the mobile phase leaving the column.
- The **eluent** is the solvent that carries the analyte.
- An **immobilized phase** is a stationary phase that is immobilized on the support particles,
- The **mobile phase** is the phase that moves in a definite direction. It may be a liquid (LC and Capillary Electrochromatography (CEC)), a gas (GC), or a supercritical fluid (supercritical-fluid chromatography, SFC).
- The **retention time** is the characteristic time it takes for a particular analyte to pass through the system (from the column inlet to the detector) under set conditions. See also: Kovats' retention index

Chromatography is based on the concept of partition coefficient. Any solute partitions between two immiscible solvents. When we make one solvent immobile (by adsorption on a solid support matrix) and another mobile it results in most common applications of chromatography. If matrix support is polar (e.g. paper, silica etc.) it is forward phase chromatography, and if it is non-polar it is reverse phase.

## 2.6.1 Types of chromatography

### 2.6.1.1 Column chromatography

Column chromatography is a separation technique in which the stationary bed is within a tube. The particles of the solid stationary phase or the support coated with a liquid stationary phase may fill the whole inside volume of the tube (packed column) or be concentrated on or along the inside tube wall leaving an open, unrestricted path for the mobile phase in the middle part of the tube (open tubular column). Differences in rates of movement through the medium are calculated to different retention times of the sample. In 1978, W. Clark Still introduced a modified version of column chromatography called **flash column chromatography** (flash). The technique is very similar to the traditional column chromatography, except for that the solvent is driven through the column by applying positive pressure. This allowed most separations to be performed in less than 20 minutes, with improved separations compared to the old method. Modern flash chromatography systems are sold as pre-packed plastic cartridges, and the solvent is pumped through the cartridge. Systems may also be linked with detectors and fraction collectors providing automation. The introduction of gradient pumps resulted in quicker separations and less solvent usage.

### 2.6.1.2 Planar chromatography

It is a separation technique in which the stationary phase is present as or on a plane. The plane can be a paper, serving as such or impregnated by a substance as the stationary bed (paper chromatography) or a layer of solid particles spread on a support such as a glass plate (thin layer chromatography). Different compounds in the sample mixture travel different distances according to how strongly they interact with the stationary phase as compared to the mobile phase. The specific Retention factor ( $R_f$ ) of each chemical can be used to aid in the identification of an unknown substance.

### 2.6.1.3 Paper chromatography

Paper chromatography is a technique that involves placing a small dot or line of sample solution onto a strip of *chromatography paper*. The paper is placed in a container with a shallow layer of solvent and sealed. As the solvent rises through the paper, it meets the sample mixture, which starts to travel up the paper with the solvent. This paper is made of cellulose, a polar substance, and the compounds within the mixture travel farther if they are non-polar. More

polar substances bond with the cellulose paper more quickly, and therefore do not travel as far.

#### **2.6.1.4 Thin layer chromatography**

Thin layer chromatography (TLC) is a widely employed laboratory technique and is similar to paper chromatography. However, instead of using a stationary phase of paper, it involves a stationary phase of a thin layer of adsorbent like silica gel, alumina, or cellulose on a flat, inert substrate. Compared to paper, it has the advantage of faster runs, better separations, and the choice between different adsorbents. For even better resolution and to allow for quantification, high-performance TLC can be used. An older popular use had been to differentiate chromosomes by observing distance in gel (separation of was a separate step).

### **2.6.2 Types of techniques on the basis of physical state of mobile phase**

#### **2.6.2.1 Gas chromatography**

Gas chromatography (GC), also sometimes known as gas-liquid chromatography, (GLC), is a separation technique in which the mobile phase is a gas. Gas chromatographic separation is always carried out in a column, which is typically "packed" or "capillary". Packed columns are the routine work horses of gas chromatography, being cheaper and easier to use and often giving adequate performance. Capillary columns generally give far superior resolution and although more expensive are becoming widely used, especially for complex mixtures. Both types of column are made from non-adsorbent and chemically inert materials. Stainless steel and glass are the usual materials for packed columns and quartz or fused silica for capillary columns.

Gas chromatography is based on a partition equilibrium of analyte between a solid or viscous liquid stationary phase (often a liquid silicone-based material) and a mobile gas (most often helium). The stationary phase is adhered to the inside of a small-diameter (commonly 0.53 – 0.18mm inside diameter) glass or fused-silica tube (a capillary column) or a solid matrix inside a larger metal tube (a packed column). It is widely used in analytical chemistry; though the high temperatures used in GC make it unsuitable for high molecular weight biopolymers or proteins (heat denatures them), frequently encountered in biochemistry, it is well suited for use in the petrochemical, environmental monitoring and remediation, and industrial chemical fields. It is also used extensively in chemistry research.

### **2.6.2.2 Liquid chromatography**

Liquid chromatography (LC) is a separation technique in which the mobile phase is a liquid. It can be carried out either in a column or a plane. Present day liquid chromatography that generally utilizes very small packing particles and a relatively high pressure is referred to as high performance liquid chromatography (HPLC).

In HPLC the sample is forced by a liquid at high pressure (the mobile phase) through a column that is packed with a stationary phase composed of irregularly or spherically shaped particles, aporous monolithic layer, or a porous membrane. HPLC is historically divided into two different sub-classes based on the polarity of the mobile and stationary phases. Methods in which the stationary phase is more polar than the mobile phase (e.g., toluene as the mobile phase, silica as the stationary phase) are termed normal phase liquid chromatography (NPLC) and the opposite (e.g., water-methanol mixture as the mobile phase and C18 = octadecylsilyl as the stationary phase) is termed reversed phase liquid chromatography (RPLC).

### **2.6.3 Specific chromatographic techniques**

#### **2.6.3.1 Affinity chromatography**

Affinity chromatography is based on selective non-covalent interaction between an analyte and specific molecules. It is very specific, but not very robust. It is often used in biochemistry in the purification of proteins bound to tags. These fusion proteins are labeled with compounds such as His-tags, biotin or antigens, which bind to the stationary phase specifically. After purification, some of these tags are usually removed and the pure protein is obtained.

Affinity chromatography often utilizes a biomolecule's affinity for a metal (Zn, Cu, Fe, etc.). Columns are often manually prepared. Traditional affinity columns are used as a preparative step to flush out unwanted biomolecules.

#### **2.6.3.2 Supercritical fluid chromatography**

Supercritical fluid chromatography is a separation technique in which the mobile phase is a fluid above and relatively close to its critical temperature and pressure.

## **2.6.4 Techniques on the basis of separation mechanism**

### **2.6.4.1 Ion exchange chromatography**

Ion exchange chromatography (usually referred to as ion chromatography) uses an ion exchange mechanism to separate analytes based on their respective charges. It is usually performed in columns but can also be useful in planar mode. Ion exchange chromatography uses a charged stationary phase to separate charged compounds including anions, cations, amino acids, peptides, and proteins. In conventional methods the stationary phase is an ion exchange resin that carries charged functional groups that interact with oppositely charged groups of the compound to retain. Ion exchange chromatography is commonly used to purify proteins using FPLC.

### **2.6.4.2 Size-exclusion chromatography**

Size-exclusion chromatography (SEC) is also known as **gel permeation chromatography** (GPC) or **gel filtration chromatography** and separates molecules according to their size (or more accurately according to their hydrodynamic diameter or hydrodynamic volume). Smaller molecules are able to enter the pores of the media and, therefore, molecules are trapped and removed from the flow of the mobile phase. The average residence time in the pores depends upon the effective size of the analyte molecules. However, molecules that are larger than the average pore size of the packing are excluded and thus suffer essentially no retention; such species are the first to be eluted. It is generally a low-resolution chromatography technique and thus it is often reserved for the final, "polishing" step of a purification. It is also useful for determining the tertiary structure and quaternary structure of purified proteins, especially since it can be carried out under nativesolution conditions.

---

## **2.7 Cytometry**

---

Cytometry is the measurement of the characteristics of cells. Variables that can be measured by cytometric methods include cell size, cell count, cell morphology (shape and structure), cell cycle phase, DNA content, and the existence or absence of specific proteins on the cell surface or in the cytoplasm.

### **2.7.1 Image cytometer**

Image cytometry is the oldest form of cytometry. Image cytometers operate by statically imaging a large number of cells using optical microscopy. Prior to analysis, cells are commonly stained to enhance contrast or to detect specific

molecules by labeling these with fluorochromes. Traditionally, cells are viewed within a hemocytometer to aid manual counting.

### **2.7.2 Flow cytometers**

Flow cytometers operate by aligning single cells using flow techniques. The cells are characterized optically or by the use of an electrical impedance method called the Coulter principle. To detect specific molecules when optically characterized, cells are in most cases stained with the same type of fluorochromes that are used by image cytometers. Flow cytometers generally provide less data than image cytometers, but have a significantly higher throughput.

Cell sorters are flow cytometers capable of sorting cells according to their characteristics. The sorting is achieved by using technology similar to what is used in inkjet printers. The fluid stream is broken up into droplets by a mechanical vibration. The droplets are then electrically charged according to the characteristics of the cell contained within the droplet. Depending on their charge, the droplets are finally deflected by an electric field into different containers.

### **2.7.3 Time-lapse cytometers**

Conventional flow and image cytometers have the disadvantage of not being able to observe cells over time. The rapid decrease in the cost of digitally storing and processing video information has led to the development of image cytometers which monitor cultured cells using time-lapse video recordings. After recording, the video is computer processed to track cytometric parameters over time. The historic information available for each cell allows time-lapse cytometers to predict the fate of a cell or to characterize its state without using the phototoxic fluorochromes that are commonly used by flow and image cytometers.

A key characteristic of time-lapse cytometers is their use of non heat-generating light sources such as light-emitting diodes. This allows a time-lapse cytometer to be placed inside a conventional cell culture incubator to facilitate continuous observation of cellular processes without heat building up inside the incubator.



## Unit -3

---

# Plasma membrane and intracellular compartments

---

### Structure of the Unit

- 3.1 Plasma membrane
  - (A) Structure
  - (B) Functions
- 3.2 Principles of Membrane Transport
- 3.3 Carrier Proteins
- 3.4 ION Channels
- 35 Endoplasmic Reticulum
  - (A) Structure
  - (B) Functions
- 3.6 Signal Recognition Particles
- 3.7 ER. Signal Peptides & Signal Transduction
- 3.8 Summary
- 3.9 Glossary
- 3.10 Self Learning Exercise
- 3.11 References

---

### 3.1 Plasma membrane

---

Every living cell is externally covered by a thin transparent electron microscopic, elastic regenerative and selective permeable membrane called plasma membrane. It is quasi fluid in nature. According to Singer and Nicolson it is “protein iceberg in a sea of lipid”. A cell wall lies external to plasmalemma in plant cells, many monerans, some protists and fungal cells. Membranes also occur inside the cells. They are collectively called biomembranes. The term cell membrane was given by C. Nageli and C. Cramer (1855) for outer membrane covering of the protoplast. It was replaced by the term plasmalemma or plasma membrane by Plowe (1931).

Proteins lipoprotein (Lipid +Protein) are the major component forming 60% of the plasma membrane. Proteins provide mechanical strength and responsible for transportation of different substances. Proteins also act as enzyme. Lipids account may 28%-79% depending upon the type of cell and organism involved (in humans, myelin 79%). Because of the presence of lipids, membranes are always continuous, unbroken structures and are deformable and their over all shape can change. The lipids of plasma membra ne are of three types namely phospholipids, glycolipids and sterols. A glycolipid may be cerebroside or ganglioside. The sterol found in the membrane may be cholesterol (Animals), phytosterol (Plants) or ergosterol (Microorganisms). A lipid molecule is distinguishable into a head of glycerol and two tails of fatty acids.

Carbohydrates form 2%–10%. Oligosaccharides are the main carbohydrates present in plasma membrane. The carbohydrates of plasma membrane are covalently linked to both lipid and protein components. The common sugars found in the plasma membrane are D – glucose, D – mannose, D – galactose, N – acetyl glucosamine, N – acetyl galoactosamine (Both are amino sugars) and sialic acid. Generally the terminal sugar of oligosaccharides is sialic acids (Also known as N – acetylneuraminic acid NANA) which gives them a negative charge.

**Structure :** Under electron microscope the plasma membrane appears three layered, i.e. trilaminar or tripertite. One optically light layer is of lipid and on both sides two optically dense protein layers are present.

Generally the plasma membrane is 75 Å thick (75 – 100Å), light layer is 35 Å while dark layers are 20 Å + 20 Å in thickness.

**Molecular structure and different models :** Several models have been proposed to explain the structure and function of the plasma membrane.

(i) **Overton's model :** It suggests that the plasma membrane is composed of a thin lipid bilayer.

(ii) **Sandwich model :** It was proposed by Davson and Danielli (1935). According to this model the light biomolecular lipid layer is sandwiched between two dense protein layers. This model was also said to be unit membrane hypothesis.

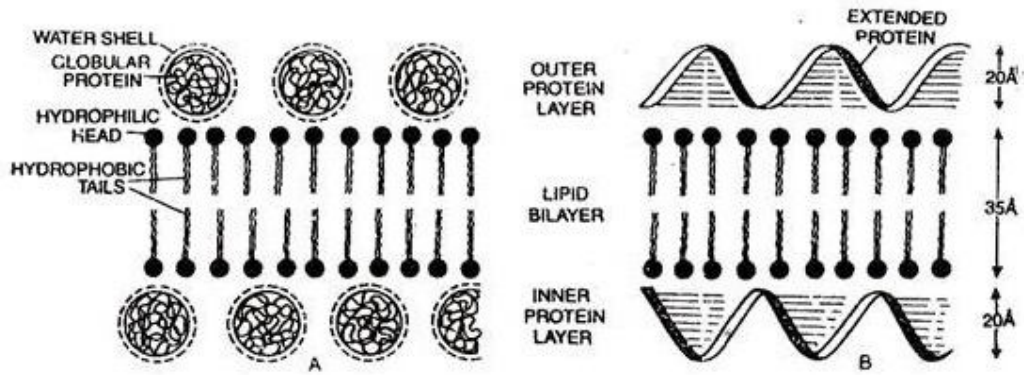

Lamellar models of plasma membrane. (A) after Danielli and Davson (1935).  
(B) unit membrane, after Robertson (1959).

(iii) **Robertson's unit membrane model** : It states that all cytoplasmic membranes have a similar structure of three layers with an electron transparent phospholipid bilayer being sandwiched between two electron dense layer of proteins. All biomembranes are either made of a unit membrane or a multiple of unit membrane. Its thickness is about 75 Å with a central lipid layer of 35 Å thick and two peripheral protein layers of 20 Å thick.

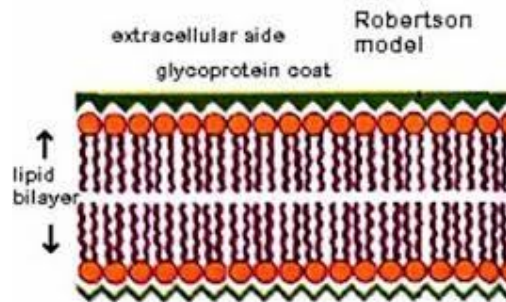

(iv) **Fluid mosaic model** : The most important and widely accepted latest model for plasma membrane was given by Singer and Nicolson in 1972. According to them it is “protein iceberg in a sea of lipids.”

## The fluid mosaic model

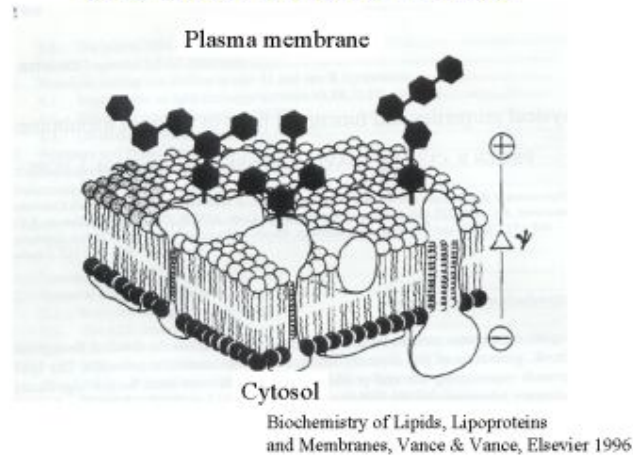

According to this model, the cell membrane consists of a highly viscous fluid matrix of two layers of phospholipid molecules. These serve as relatively impermeable barrier to the passage of most water soluble molecules. Protein molecules occur in the membrane, but not in continuous layer; Instead, these occur as separate particles asymmetrical arranged in a mosaic pattern.

Some of these are loosely bound at the polar surfaces of lipid layers, called peripheral or extrinsic proteins. Others penetrate deeply into the lipid layer called integral or intrinsic proteins. Some of the integral proteins penetrate through the phospholipid layers and project on both the surface. These are called trans membrane or tunnel proteins (glycophorins). Singly or in groups, they function as channels for passage of water ions and other solutes. The channels may have gate mechanism for opening in response to specific condition. The carbohydrates occur only at the outer surface of the membrane. Their molecules are covalently linked to the polar heads of some lipid molecules (forming glycolipids) and most of the proteins exposed at outer surface (forming glycoproteins).

The sugar protions of glycolipids and glycoproteins are involved in recognition mechanisms :-

- (a) Sugar recognition sites of two neighbouring cells may bind each other causing cell to cell adhesion. This enables cells to orientate themselves and to form tissues.
- (b) Through glycoproteins, bacteria recognise each other. e.g., female bacteria are recognised by male bacteria.

- (c) These provide the basis of immune response and various control system, where glycoproteins act as antigens. Lipid and integral proteins are amphipathic in nature i.e., they have hydrophilic and hydrophobic groups within the same molecules. The NMR (Nuclear magnetic resonance) and ESR (Electron spin resonance) studies showed that the membrane is dynamic. The lipid tails show flexibility. The molecule can rotate or show flip flop motion.

#### Difference between protein types

Extrinsic Protein	Intrinsic Protein
These are associated with surface only.	These lie throughout phospholipid matrix and project on both surfaces, also called transmembrane or tunnel protein.
They form about 30% of the total membrane protein.	They form about 70% of total membrane proteins.
Example – Spectrin in red blood cells & ATPase in mitochondria.	Example – Rhodopsin in retinal rod cells.

#### Membrane protein can be of following types with different functions

**Carrier molecules :** These bind with the specific molecules into or out of the cell. This provides selective exchange of materials. The carrier protein molecules are called “permeases” e.g.,  $Na^+ - K^+$  pump,  $Na^+$  – sugar transport.

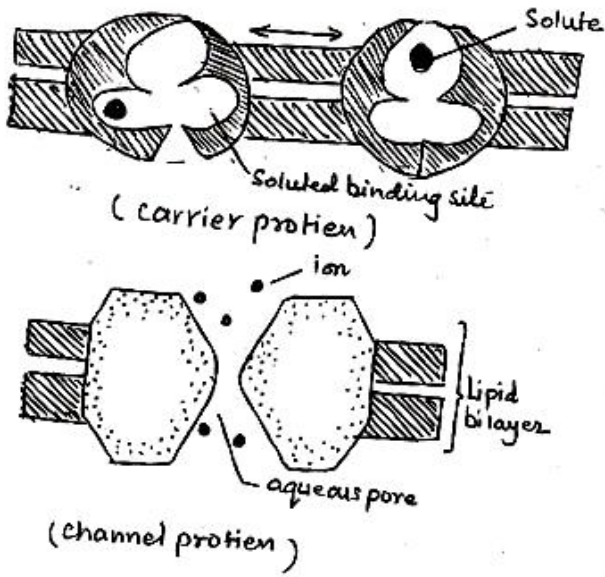

(ii) **Receptor molecules** : The glycoproteins on the cell surface act as receptors that recognize and bind with specific molecules.

(iii) **Enzyme molecules** : The inner mitochondrial membrane carrier enzyme comprising the electron transport chain for cellular respiration.

(6) **Cell membranes are fluid and dynamic due to**

(i) The constituent molecules can move freely in the membrane.

(ii) The cell membranes are constantly renewed during the cells life.

(iii) They can repair minor injuries.

(iv) They expand and contract during cell movement and during change in shape.

(v) They allow interactions of cells such as recognition of self and fusion of cells.

(7) **Membrane permeability** : According to permeability, membranes are classified as –

(i) **Permeable membrane** : They allow both solvent and solute molecules or ions through them. e.g., cellulose wall, lignified cell walls.

(ii) **Impermeable membrane** : They do not allow solute and solvent molecules. e.g., heavily cutinised or suberinised cell walls in plants.

(iii) **Semi-permeable membrane** : They allow solvent molecules only. e.g., membranes of colloidion, parchment paper and copper ferrocyanide membranes.

(iv) **Differentially permeable membrane** : All membranes found in plants allow some solutes to pass through them along with the solvent molecules. e.g., plasma membrane, tonoplast (vacuolar membrane) etc.

**Intercellular communications/modification of plasma membrane/following structures are derived from plasma membrane**

(i) **Microvilli** : They are fingers like evaginations of  $0.1 \mu^m$  diameter, engaged in absorption. e.g., intestinal cells, hepatic cell, mesothelial cells. The surface having microvilli is called striated border or brush border.

(ii) **Lomasomes** : They are plasmalemma foldings found in fungal cells.

(iii) **Mesosomes** : It serves as site for cellular respiration in prokaryotes.

(iv) **Tight junctions** : Plasma membrane of two adjacent cells are fused at a series of points with a network of ridges or sealing strands. e.g., capillaries, brain cells collecting tubules etc.

(v) **Plasmodesmata** : They are protoplasmic bridges amongst plant cells, which occur in area of cell wall pits. It was discovered and reported by Tangle and Strasburger respectively.

(vi) **Desmosomes** : concerned with cell adherence.

(9) **Functions**

(i) They control the flow of material through them and provides passage for different substances.

(ii) It is differentially permeable, solute particles ( $1-15 \text{ \AA}$ ) can pass through it.

(iii) It is not only provides mechanical strength but also acts as a protective layer.

(iv) Plasma membrane is responsible for the transportation of materials, molecules, ions etc.

(v) It helps in osmoregulation.

(vi) Diffusion of gases take place through plasma membrane by simple and facilitated diffusion.

(vii) Transport of ions, small polar molecules through active (energy used) and passive transport (energy not used).

(viii) Gases like  $O_2$  and  $CO_2$  diffuse rapidly in solutions through membranes.

(ix) Ions and small polar molecules diffuse slowly through the membranes.

(x) Some solute molecules or ions first bind with certain specific carrier or transport proteins called permeases.

(xi) Water as well as some solute molecules and ion pass through membranes pores; pores are always bordered by channel proteins.

(xii) When diffusion takes place through channel, called simple diffusion and through carrier proteins, called facilitated diffusion.

---

## 3.2 Principles of Membrane Transport

---

**Membrane transport :** It is passage of metabolites, by-products and biochemicals across biomembrane. Membrane transport occurs through four methods—passive, facilitated, active and bulk. Size of the particles passing through plasmalemma is generally 1 – 15 Å.

(i) **Passive transport :** No energy spent. Passive transport occurs through diffusion and osmosis.

(a) **Diffusion :** It is movement of particles from the region of their higher concentration or electrochemical potential to the region of their lower concentration or electrochemical potential. Electrochemical potential operates in case of charged particles like ions. Diffusion can be observed by opening a bottle of scent or ammonia in one corner, placing a crystal of copper sulphate in a beaker of water or a crystal of  $KMnO_4$  on a piece of gelatin. Simple diffusion does not require carrier molecules.

**Independent Diffusion :** In a system having two or more diffusion substances, each individual substance will diffuse independent of others as per gradient of its own concentration, diffusion pressure or partial pressure from region of higher one to region of lower one.

Rate of diffusion is proportional to difference in concentration and inversely to distance between the two ends of the system, inversely to square root of relative density of substance and density of medium, directly to temperature and pressure.



(b) **Osmosis** is diffusion of water across a semipermeable membrane that occurs under the influence of an osmotically active solution.

(c) **Mechanism of passive transport** : Passive transport can continue to occur if the absorbed solute is immobilised. Cations have a tendency to passively pass from electropositive to electronegative side. While anions can pass from electronegative to electropositive side. There are two modes of passive transports.

**Lipid matrix permeability** : Lipid soluble substances pass through the cell membrane according to their solubility and concentration gradient, e.g., triethyl citrate, ethyl alcohol, methane.

**Hydrophilic membrane channels** : They are narrow channels formed in the membrane by tunnel proteins. The channels make the membrane semipermeable. Water passes inwardly or outwardly from a cell through these channels according to osmotic gradients.  $CO_2$  and  $O_2$  also diffuse through these channels as per their concentration gradients. Certain small ions and other small water soluble solutes may also do so.

(d) **Ultrafiltration** is fine filtration that occurs under pressure as from blood capillaries, epithelia and endothelia. It is of two types : –

Paracellular through leaky junctions or gaps in between cells.

Transcellular through fenestrations in the cells. ‘Dialysis’ is removal of waste products and toxins from blood by means of diffusion between blood and an isotonic dialysing solution.

(e) **Facilitated transport or Facilitated diffusion** : It is passage of substances along the concentration gradient without expenditure of energy that occurs with the help of special permeating substances called permeases. Permeases form pathways for movement of certain substances without involving any expenditure of energy. At times certain substances are transported alongwith the ones requiring active transport. The latter phenomenon called cotransport. Facilitated transport occurs in case of some sugars, amino acids and nucleotides.

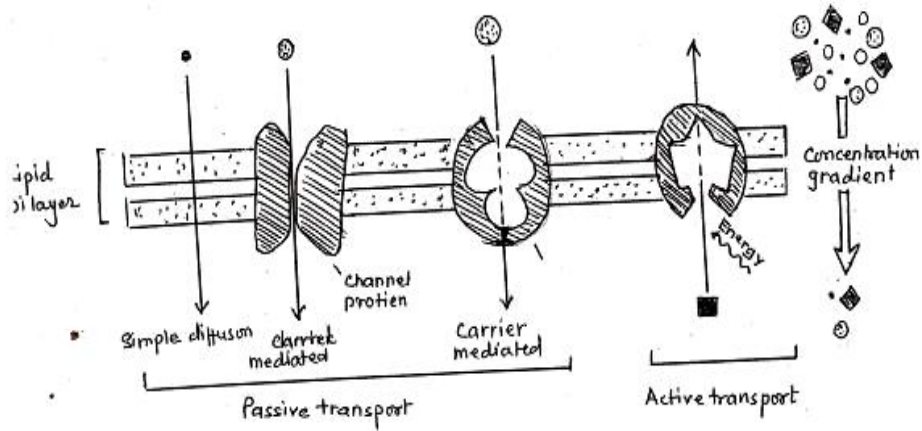

(ii) **Active transport** : It occurs with the help of energy, usually against concentration gradient. For this, cell membranes possess carriers and gated channels.

---

### 3.3 Carrier particles or Proteins

---

They are integral protein particles which have affinity for specific solutes. A solute particles combines with a carrier to form carrier solute complex. The latter undergoes conformational change in such a way as to transport the solute to the inner side where it is released into cytoplasm.

3.4 Ion Channels / **Gated channels** : The channels are opened by either change in electrical potential or specific substances, e.g., Calcium channels.

Active transport systems are also called pumps, e.g.,  $H^+$  pump,  $K^+$  pump,  $Cl^-$  pump,  $Na^+ - K^+$  pump. The pumps operate with the help of ATP.  $K^+ - H^+$  exchange pump occurs in guard cells.  $Na^+ - K^+$  exchange pump operates across many animal membranes. For every ATP hydrolysed, three  $Na^+$  ions are passed out while two  $K^+$  ions are pumped in. Sea Gulls and Penguins operate  $Na^+ - K^+$  pump for excreting NaCl through their nasal glands. Active transport of one substance is often accompanied by permeation of other substances. The phenomenon is called secondary active transport. It is of two main types, cotransport (e.g., glucose and some amino acids alongwith inward pushing of excess  $Na^+$ ) and counter-transport ( $Ca^{2+}$  and  $H^+$  movement outwardly as excess  $Na^+$  passes inwardly).

---

### 3.4 Endoplasmic Reticulum

---

Though Endoplasmic Reticulum (E.R), a part of cytoplasm vesicular system was first observed by Grainier (1897) and named it as ergastoplasm, but its ultrastructure was first given by Porter, Claude and Fullan (1945) term ER was coined by K.R. porter (1953).Porter defined ER as a “well developed electron microscopic network of interconnected cisternae, tubules and vesicles present throughout the cytoplasm, especially in the endoplasm.

The ER is found almost all animal and plant cells. The only exceptions are mature erythrocytes and prokaryote. It can be recognised as early as in the two celled stage.Development of ER depends upon the metabolic state and stage of differentiation of the cells eg. absent from embryonic cells, less developed in spermatocytes (only a few vesicles) well developed in fully differentiated and metabolically active cells like animal cells of pancreas, hepatocytes of liver etc.

#### **Types of Endoplasmic Reticulum**

There are two basic morphological types of the ER, rough ER (RER) or granular form (ergastoplasm) and the smooth ER (SER) or agranular form. Originally the Golgi complex was included in the SER but was later considered as a separate system. The rough ER is so called because the membrane are covered with ribosomes, giving them a rough appearance in sections. The smooth ER membranes are not covered with ribosomes. Depending upon the metabolic requirements of the cell, RER and SER are inter convertible.

#### **1. Rough Endoplasmic Reticulum (RER)**

The RER is predominant in cells which actively synthesize proteins eg. The enzyme secreting cells. Generally it is found in that part of cytoplasm which is basophilic (ergostoplasm) a property which is attributed to attached ribosomes which contain RNA. Only rarely it has been found that basophilic region is devoid of ER, since in these regions ribosomes are free. Such regions are found in embryonic animal and plant cells.RER is particularly well developed in pancreatic and liver cells where secretory proteins are synthesized on the attached ribosomes and are translocated through cisternae to different sites in the cells.

#### **2. Smooth Endoplasmic Reticulam SER ( AGLANULAR )**

The SER is characteristic of cells in which synthesis of non protein substances like phospholipids, glycolipids and steroid hormones takes place e.g. adipose tissue cells, adrenocortical cells and interstitial cells

of the testis. Smooth ER forms a continuous system with rough ER, but was of different morphology. It consists of smooth membrane segments and found in regions rich in glycogen. SER is used for the formation of transport vesicles, which carry proteins and lipids to the Golgi complex.

**Differences between RER and SER**

Character	SER	RER
Ribosomes	Absent	Present
Position	Mainly present near the cell membrane	Mainly present near the nucleus
Components	Mainly formed of tubules	Mainly formed of cisternae
Occurrence	Mainly found in lipids or steroids forming cells or glycogen ( fat cells of adipose connective tissue) interstitial cells (of testis) glycogen-storing cells (of liver ) muscle cells, leucocytes, retinal cells etc.	Mainly found in protein forming cells e.g. animal cells ( pancreas) goblet cells ( gut cells secreting mucus) plasma cells ( antibodies producing cells ), Nissil granules of endocrine cells ( anteriorpituitary) etc.
5) Function	Lipid synthesis	Protein synthesis

**Ultra structure**

Electron microscopic studied showed the presence of 3 types of Element's in ER.

**Cisternae** : These are narrow, two-layered and unbranched elements generally present near the nucleus. These lie one upon the other and may be interconnected. Each is about 40-50um in diameter and studded with ribosomes.

Ribosomes attached to ER by a glycoprotein are called ribophorin.

These are abundant in protein forming cells.

Each cisternal of ER has two surfaces :

Cytoplasm or protoplasmic face cis with ribosomes and in direct contact with cytosol )

Luminal face ( towards the cisternal space and borders the cavities of cisternal )

**Vesicles** – These are oval or spherical elements scattered in the cytoplasm. Size ranges from 25-500  $\mu\text{m}$  in diameters.

These often occur isolated in the cytoplasm and are also studded with ribosomes thus mainly found in protein forming cells.

### **Tubules**

These are wider, tubular and branched elements mainly present near the cell membrane. Each is about 50-100  $\mu\text{m}$  in diameters.

These are without ribosome so are more in lipid and steroids forming cells and the cells involved in glycogen metabolism.

In liver cells, fine tubules with glycogen granules are called glycosomes.

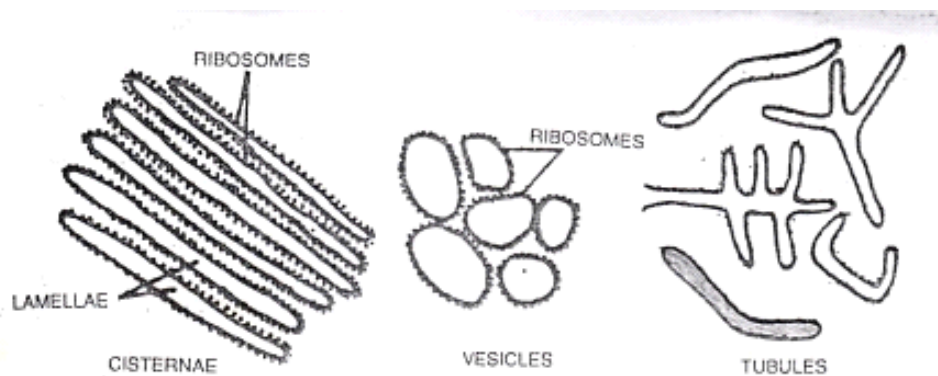

Three types of elements of ER may be present within the same cell and are interconnected with one another, and are also connected with the membrane of other cell organelles like Golgi body, mitochondria, nuclear membrane and even with the cell membrane to form a cytoplasm vacuole system.

ER forms about 30% to 60% (average 50% ) of the cytoplasm vascular system and 10% of total cell volume. ER also contains a fluid called endoplasmic matrix in the elements.

## 1. Modifications of ER

Sarcoplasmic reticulum – A modified form of the SER is the sarcoplasmic reticulum found in striated muscles. (Fig 1) this is a delicate plexus surrounding the myofibrils. The longitudinal sarcoplasmic tubules merge to form terminal cisternae. A terminal cisternae from each sarcomere, together with a small transverse tubule between them, constitute a triad, which lies over the I band. Along the H band level is a central cisternae which have pores. The central cisternae are formed by confluence of the longitudinal sarcoplasmic tubules. In some muscles the triad lies over the functions of A and I bands, and thus there are two triads per sarcoma.

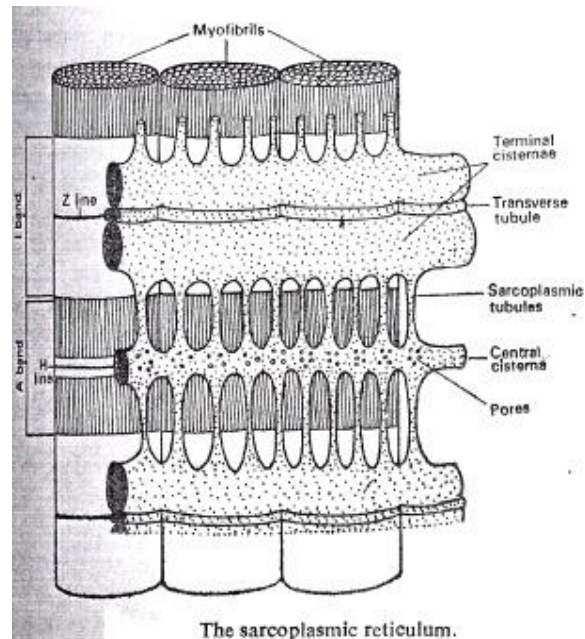

It helps in distributing energy-rich material from muscular contraction. It provides channels for conducting the nerve impulses on the whole muscle fibers. It also helps in expelling of lactic acid formed during muscle contraction. So prevents muscle fatigue.

## 2. **Ergastoplasm or Basoplasm or Chromodial Substance**

It is an accumulated mass of cisternae with ribosomes (i.e. RER) present in the cytoplasm of some metabolically active cells. Term ergastoplasm was coined by Garnier (1899). In the cyton of neurons, such bodies are called Nissl granules (also called trigoid granules). Casperson (1955) found it to be basophilic in nature due to the presence of RNA

**Function** It is involved in protein synthesis.

3. **Myeloid bodies** – These are found in retinal cells. Each myeloid body is a biconvex, about 4-5  $\mu\text{m}$  long formed from stacks of packed tubules so are modified SER and not associated with ribosomes.

**Function** These are probably related with photoreception.

### **Annulated lamella –**

These are found in immature oocytes and spermatocytes (afzelius, 1955) and were first reported in the oocytes of sea Urchin -Arbacia.

These occur either in the form of free unstacked vesicles in the cytoplasm or as stacked annulated lamella (2-12 in number) near the nucleus. Two membranes are interspaced by 20-40nm.

### **Interrelationship between ER and other membrane**

Watson (1955) demonstrated continuity between the outer nuclear membrane and the ER. The ER also shows connections with the plasma membrane and Golgi complex. It is suggested that :

Ectokaryotheca of nucleus form vesicles by blebbing.

These vesicles fuse to form annulated lamella.

Annulated lamella loses their pore complexes, become associated with the ribosomes and form RER cisternae.

RER produces transition vesicles which fuse to form the cisternae of Golgi complex.

Golgi body forms the vesicles which fuse to form the plasma lemma (Northcote, 1971).

Golgi body also gives rise to secretory granules and primary lysosomes by blebbing.

Plasmalemma invaginates to form pinocytotic vesicles.

Pinocytotic vesicles and primary lysosomes fuse to form the secondary lysosomes (Novikoff, 1962).

RER loses the ribosomes to form SER.

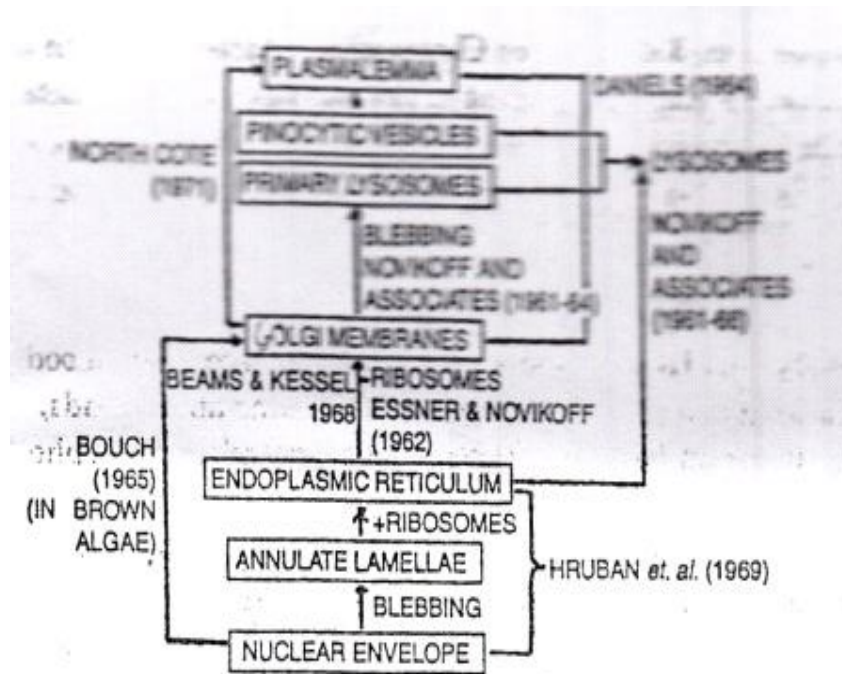

Interrelationship of the different cells.

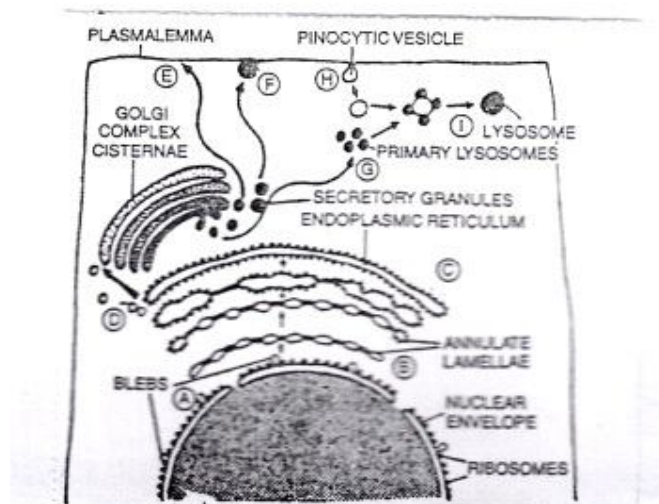

Interrelationships between different membranes of the cell.

### Origin

Most accepted view, regarding the origin of ER is that RER arises as an evagination of outer nuclear membrane (Palade, 1956) while SER is formed



from RER by the loss of ribosomes. This view is supported by the following similarities between ER and nuclear membrane.

Both are similar in chemical composition (lipoproteinous and trilaminar).

Intercisternal space of ER is continuous with perinuclear space.

Both RER and ectokaryotheca of nuclear envelope are studded with ribosomes.

Fluid present in the ER cisternae and per nuclear space is of similar nature.

Derivation of SER from RER is further proved by the use of radioactively labelled amino acids.

### **Function of ER**

Common function of ER

**Intracellular transport** – ER acts as cell-circulatory system (Palade, 1956) and helps in transportation of materials inside the cell. Eisner and Novikoff (1962) suggested a directional flow of materials as under.

**RER SER Golgi body** Primary lysosome \_\_\_\_ out of cell(exocytosis).

**Storage** – ER helps in storage of metabolic products of cell. eg. glycogen

**ATP Synthesis** – ER is the site of ATP synthesis to provide energy for intracellular transport materials or RNA metabolism.

**Cytoskeleton** – ER is the major component of cytoplasm – vacuole system which acts as cytoskeleton and provides mechanical support and a definite shape to the cell.

**Formation of cell plate** – During cytokinesis in the plant cells, ER provides small sized phragmoplasts which arrange themselves at the equator and later fuse to form the cell plate which changes into the middle lamella at the end.

**Transportation of genetic information** – ER acts as a passage for the transportation of genetic informations from the nucleus through various cell organelles to control biosynthesis of proteins, fats and carbohydrates.

**Photoreception** – ER of pigmented epithelial cells of retina act as a photoreceptor.

**Formation of primary lysosome** –It forms primary lysosomes with hydrolytic enzymes (Novikoff, 1965).

### **Functions of RER –**

**Protein synthesis** – Palade (1951) reported that there is a direct and close correlation between the RNA content of the microsomal fraction and rate of

protein synthesis. RER provides two dimensional arrangement of the ribosomes and increases the of protein synthesis.

Formation of SER from RER by the loss of ribosomes.

RER packages the polypeptides into the proteins.

**Formation of transition vesicles** – RER forms the transition or transport vesicles which carry the materials like the proteins to the cisternae of Golgi apparatus for their condensation into secretory vesicles.

**Formation of nuclear envelope** – Porter and machado (1960) reported that nuclear membrane break into a number of fragments which merge with the ER elements during later stages of prophase of mitosis and meiosis. Nuclear envelope is reformed from the cisternae of ER during telophase of cell division.

### **Function of SER**

**Lipid synthesis** – Christensen (1963) reported a correlation between the relative amount of a granular ER and rate of lipid (e.g. triglyceride) synthesis in the adipocytes.

**Detoxification of drugs** – Claude (1970) demonstrated that there is considerable hypertrophy of SER when drugs like phenalbital, steroid hormones, carcinogens etc are administered.

SER is also involved in synthesis of ascorbic acid.

**Fat oxidation** - SER membrane have enzymes to regulate the initial reactions in the oxidation of fats.

**Synthesis of steroid hormones** – Amount of SER has been found to be well developed in those cells which are involved in the biosynthesis of steroid hormones. E.g. corticoids in adrenal cortex ( Rodin, 1971) ; testosterone in the interstitial cells of testes of opossum ( Christensen and Fawcett, 1961) and estrogens in the follicular cells of mature ovarian follicle.

---

## **3.5 Signal Recognition Particles**

---

The signal recognition particle (SRP) is an abundant, cytosolic, universally conserved ribonucleoprotein( protein-RNA complex ) that recognizes and targets specific proteins to the ER in eukaryotes and the plasma membrane in prokaryotes. The eukaryotic SRP is composed of 6 distinct polypeptides bound to an RNA molecule with GTase activity. The components are SRP6

SRP14, SRP19, SRP54, SRP68, SRP72 & SRPRNA while in prokaryotes it is composed of only one polypeptide bound to an RNA molecule, its components of the complex are FtsH and 4.5SRNA.

### Signal Hypothesis

Free ribosomes synthesize mostly soluble proteins whereas RER bound ribosomes manufacture transmembrane proteins and proteins destined for secretion. These large protein molecules pass through the RER membrane. Gunter Blobel, Cesar Milstein, and David Sabatini formulated “signal hypothesis” which partially explains how this happens. These proteins are synthesized with a leading (N-terminal) signal peptide. A signal peptide first protrudes beyond the ribosomal surface after a little growth. At this stage a complex of polypeptide and RNA molecule called signal recognition particle binds to ribosome which arrests further polypeptide growth and prevents it from being released in the cytosol. The SRP-ribosome complex diffuses to the RER surface, where it is bound by the SRP receptor, which stimulates the bound ribosome to resume polypeptide elongation and facilitates the passage of growing polypeptides N-terminal through the membrane into the lumen of RER. After entry of polypeptide, signal peptide is removed in the presence of signal peptidase enzyme. The other enzymes of lumen cause post-translational modification of still growing polypeptide chain. When protein synthesis is completed, secretory, ER and lysosomal proteins pass completely through the RER membrane into the lumen. Transmembrane proteins remain embedded in the ER membrane with their C-terminal on its cytoplasmic side.

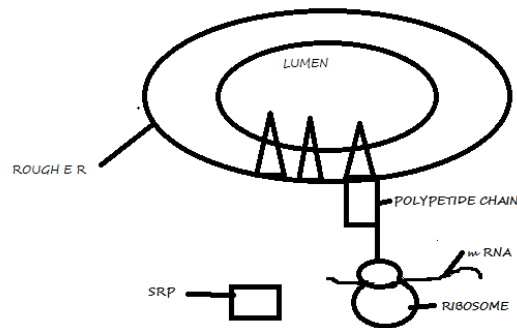

SIGNAL HYPOTHESIS-ENTRANCE OF POLYPEPTIDE CHAIN IN LUMEN OF RER THROUGH SRP RECEPTOR.

---

### 3.6 ER. Signal Peptides & Signal Transduction

---

Permeability of plasma membrane is one of the most crucial feature of any cell. It is impermeable to certain water soluble materials as they have to react with protein resident in the plasma membrane. The extracellular material is called a legend and the target protein to which it binds is known as receptor. When membrane bound receptor respond to legend binding by triggering a response pathway in the cytosol, the process is designated as signal transduction. It amplifies the original signal and convert it from an inactive to an active form. In its active form, the receptor stimulates a catalytic activity that generates a cytosolic signal whose amplitude is much greater than the original extracellular signal( the ligand ). A molecule produce in response to transduction of an extracellular signal is called a second messenger ( ligand first messenger).

The receptor may be a transmembrane protein with domain on both the extracellular side and cytoplasmic side. The receptor may interact with a G–protein that is associated with the membrane. It causes a chain of events in cytoplasm which often stimulate the production of second messenger, the classic example being the production of cyclic AMP ligand –binding may trigger the process of internalization,in which the receptor–ligand combination is brought into the cell by the process of endocytosis.

---

### 3.8 Glossary

---

- **Plasma membrane** ; A sheet-like membrane,7.5-10nm thick, that forms a selectively permeable barrier enclosing and delimiting the protoplasm of a cell. It is a living structure consisting of lipid molecules in a fluid bilayer, and associated proteins.
- **Active Transport**; The transport of substances across a membrane against a concentration gradient .Such process require, the source of energy often being ATP.
- **Passive Transport**; The transport of molecules across a membrane from higher conc. To lower conc. by diffusion, facilitated-diffusion, filtration or across a semipermeable membrane by osmosis.
- **Endoplasmic reticulum**; A complex network of cytoplasmic membranaeous sacs and tubules which appears to be continuous with both the nuclear and cell membranes .It occurs in two forms; that bearing ribosomes are termed as rough ER; that without ribosomes are

smooth ER. Both are involved in the synthesis, transport and storage of cells.

- **Signal Transduction;** Conversion of a signal from one physical or chemical form to another. It is the process by which a cell produces a response to an extracellular signal.

---

### 3.9 Self Learning Exercise

---

#### Section A (Very Short Answer Type)

1. Term Plasma membrane was given by-----.
2. Sandwich model of PM was given by -----.
3. The mostly widely accepted model of plasma membrane was given by ---  
-----.
4. The membrane which allows only solvent molecules to pass through is known as -----.
5. Energy is required in which transport mechanism .
6. SER is responsible for ----- synthesis.
7. RER is responsible for ----- synthesis.
8. Endoplasmic reticulum term was coined by -----.

(Ans.: Plowe in 1937, Davson & Danielli in 1935, Singer & Nicolson in 1972, Semipermeable membrane, Active Transport, Lipid, Protein, K.R. Porter )

#### Section B ( Short Answer Type)

1. Define Plasma membrane.
2. Describe Robertson's unit membrane model of plasma membrane.
3. Differentiate between active and passive transport mechanism.
4. What are the carrier proteins.
5. What is the Signal hypothesis.

#### Section C ( Long Answer Type)

1. Explain the Fluid mosaic model in detail.
2. What are the functions of plasma membrane.
3. Differentiate between RER and SER.
4. Give an account of function of ER.

5. Explain Signal transduction in detail.

---

### 3.10 References

---

- Campbell, Essential Biology (Abridged), Cambridge.
- Starr & Taggart, Biology : The Unity and Diversity of Life.
- Lehninger : Principles of Biochemistry.
- Lubert Stinger : Biochemistry
- Donald Voet & Judith.G.Voet – Biochemistry.
- Murary : Harper’s Biochemistry
- Geoffry.M Cooper and Robert.E.Hansmann : The Cell
- McDanel TG. MicroRNA: Mechanism of gene regulation and application to livestock.J. Anim. Sci. 2009. 87(E. Suppl.):E21–E28.
- Watson et al. Molecular Biology of the Gene, Sixth Edition, 2008. Watson JD, Baker TA, Bell SP, Gann A, Levine M, Losick R. (Benjamin Cummings, San Francisco).

# Unit - 4

---

## Vesicular Traffic Organelles

---

### Structure of the Unit

- 4.0 Objective
- 4.1 Golgi Complex
  - 4.1.1 Structure
  - 4.1.2 Functions
- 4.2 Lysosomes
  - 4.2.1 Structure
  - 4.2.2 Functions
- 4.3 Transport From Golgi Bodies To Lysomes
- 4.4 Endocytosis & Exocytosis
- 4.5 Microbodies
  - 4.5.1 Glyoxysomes
    - (A) Structure
    - (B) Functions
  - 4.5.2 Peroxysomes
    - (A) Structure
    - (B) Functions
  - 4.5.3 Spherosomes
    - (A) Structure
    - (B) Functions
- 4.6 Summary
- 4.7 Glossary
- 4.8 Self Learning Exercise
- 4.9 References

---

## 4.0 Objective

---

After going through the unit you will be able to understand the structure and function of the Golgi complex, Lysosomes and the phenomenon of endo and exo cytosis .Later in the unit the microbodies of the cell which are important in vesicular transport have been described .

---

## 4.1 Golgi Complex

---

The Golgi apparatus was one of the first organelles to be discovered and studied in detail. In 1898, Italian physician Camillo Golgi while investigating the nervous system of Barn owl, discovered this structure termed as internal reticular apparatus. But later in 1890, this apparatus was named after him. (Previously as this apparatus was known to be network, they were also called dictyosomes (Greek, dactyls = net)

The number, shape & position of the Golgi complex varies according to its function it performs. In varies in form from a compact mass to a disperse filament as network. The size is also linked to the functional state. It is large in nerve and gland cells but small in muscles.

The formation of Golgi complex may be from the pre-existing stacks by division of fragmentation or from the rough ER, which changes to smooth ER and then eventually becomes the Golgi Cisternae.

The Golgi complex is usually situated near the nucleus, receives proteins and lipids from the ER, modifies them and then dispatches them to other destinations in the cell.

In animal cells, Golgi complex breaks up and disappears following the onset of mitosis. It reappears during telophase of mitosis. In plants and yeast the Golgi complex remain intact throughout the cell cycle



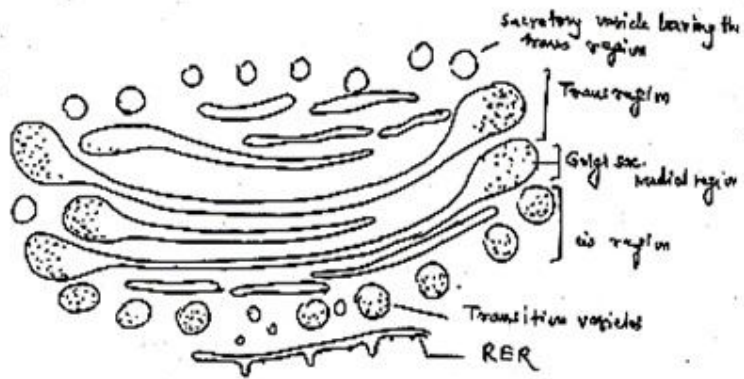

**Function**

Golgi complex have several functions, they are as following:

1. It plays important role in protein secretion.
2. It plays role in secretion as it secretes granules which in turn fuse to
3. form large secretory granules In many cases the individual cisternae on the maturing face may be completely filled with secretory products and forms secretory granules.
4. Synthesizes and seretes of polysaccharides
5. Sulphation Sulphotransferases enzymes have been found in the Golgi complex, hence it takes part in sulphate metabolism.
5. Plasma membrane formation

The Golgi complex renews the plasma membrane constituents and also synthesis carbohydrate components of the plasma membrane.

6. Plant cell wall formation

The fibrils which make the cell well of plants are made of polysacchrides are formed in the Golgi complex. Substances like formed in the Golgi complex. Substances like pectin and nemmicelluloges are also formed by the Golgi complex.

7. Lipid packaging and secretion

Golgi complex plays important role in concentrating and modifying the secretory material (formation of chylomicrons). These Golgi complex derived vesicles act as transport vesicles for lipoid to the plasma membrane and the intercellular space.

8. Acrosome formation

It form spherical body with parallel flattened cisternae and vacuoles appear at the anterior end of the developing spermatid called acrosome.

Proacrosomal granules appear in the centre of the Golgi complex and ultimately fuse to form acrosome. This acrosome have lytic substances which help in penetration of the sperm into the Ovum.

9. Lysosomes formation

The cisternae of the Golgi complex form vesicles by blebbing which in turn with other pinocytic vesicles or with autophagic vesicles form lysosomes. Lysosomes may also arise directly from ER.

10. Regulation of fluid balance

The Golgi complex in Metazoans works similarly as contractile vacuole of Protozoan's, it expels surplus water from the cells.

11. The Golgi complex have Golgi anti apoptotic protein which protects cells from apoptosis.

---

## 4.2 Lysosome

---

Lysosomes are membrane bound organelles found in animals. Lysosomes are storage organelles for hydrolases remain an inactive form. Activation takes place when the lysosome fuses with a specific organelle to form a hybrid structure.

De Duve in 1955 reported them for the first time. Lysosomes are a combined product of the endoplasmic reticulum and the Golgi apparatus and contain a large number of hydrolytic enzymes.

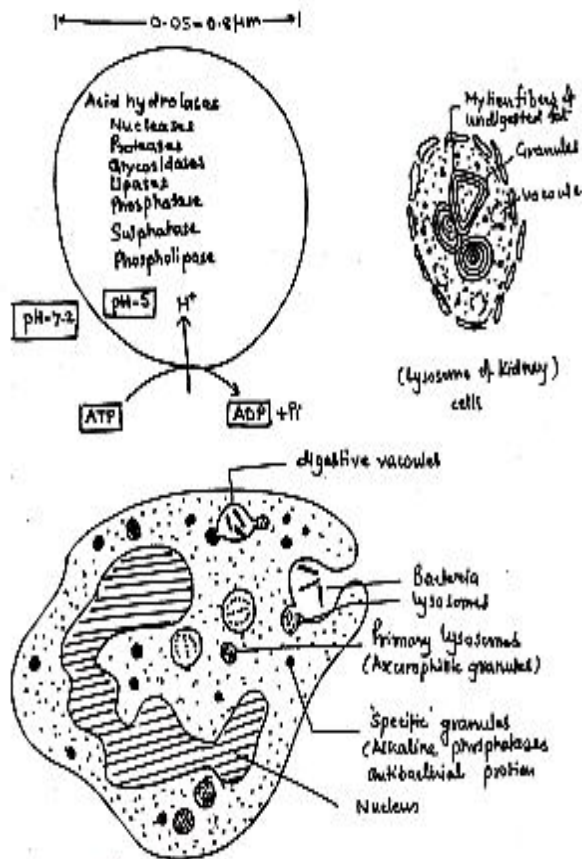

and hydrolases that  
maintained by an H<sup>+</sup>  
pH = 5 (Albert's text).

### Kinds of Lysosomes (Polymorphism Of Lysosomes)

De Robertis et al. (1971) gave the concept of polymorphism of lysosomes. According to him, This polymorphism is due to the association of primary lysosomes with the different materials that are engulfed by the cells.

They are of four types:

- (i) Primary
- (ii) Secondary
- (iii) Residual bodies
- (iv) Autophagosomes or cytolysosomes

#### (1) Primary Lysosomes : (Storage granules)

They are also known as storage granules as they are small sac like filled with enzymatic contents that are synthesized by ribosome and accumulated in ER. From there they enter the Golgi in GERL region which is known to be involved in the production of lysosomes. These lysosomes comprise only one type of enzyme or another.

(2) **Secondary lysosomes : (Digestive Vacuole or Heterophagosome)**

The phagosomes or pinosomes when fuse with primary lysosomes, they are known as secondary lysosomes. These lysosomes have engulfed material and hydrolytic enzyme within its membrane. These lysosomes digest the engulfed material and passes through the lysosomal membrane into the cytoplasm for metabolic uses.

(3) **Residual bodies :**

Due to lack of certain enzymes in the lysosomes, its own digestion is incomplete thus they form residual bodies. These bodies are eliminated by the organism and sometimes, they are retained in the body causing ageing. These residual bodies may cause fever, hepatitis, hypertension etc in human beings or may form myelin figures, due to accumulation of debris which are mostly lipid in nature.

(4) **Autophagic vacuole (Cytolysosome or autophagosomes)**

Sometimes, intracellular parts such as mitochondria or endoplasmic reticulum may be digested by the lysosomes. Such lysosomes are known as cytolysosomes or autolysosomes or autophagic vacuoles, Under physiologic or pathologic conditions, these autophagic vacuoles may cause digestion without irreparable damage. During starvation, liver cells. shows numerous autophagosomes.

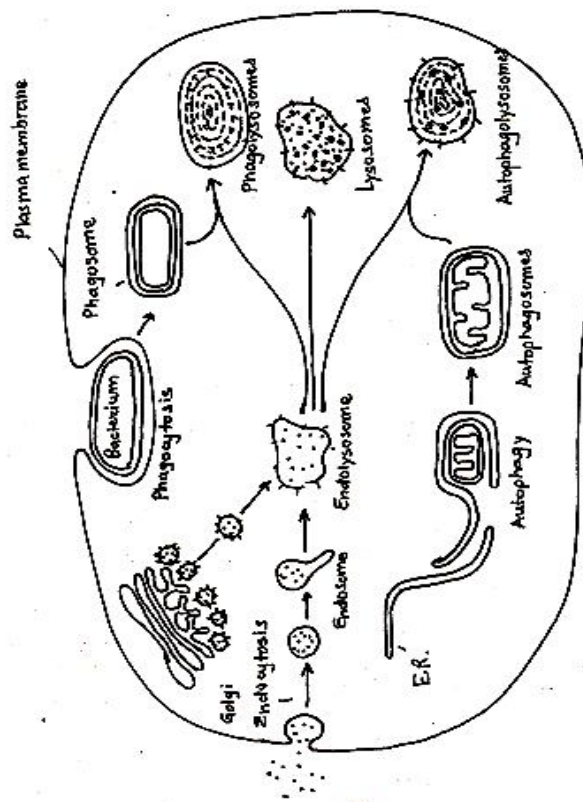

(ORIGIN OF THREE TYPE OF LYSOSOMES)

## **Functions:**

### **1. Intracellular Digestion :**

The endocytosed macromolecules formed by the process of phagocytosis or pinocytosis are digested by the lysosomes. Phagosomes or pinosomes fuse with the lysosomes to bring about the digestion.

Sometimes, the cell organelle of the same cell fuses with the cell's own lysosome to form autophagosomes which are then by the action of certain proteolytic enzymes, (Catepsins) are digested.

To get rid of cell debris of the dead cells, the cells have a mechanism of autodigestion. During autodigestion, when a cell dies, the lysosome membrane ruptures and the enzymes are liberated, which then digest the dead cell.

### **Extracellular Digestion:**

### **3. Role In The Process Of Fertilization :**

During the penetration of sperm into the ovum, the lysosomal enzymes play the important role. Acrosome contains protease, hyaluronidase and acid phosphatases which digest the zona pellucida making a passage through which sperm nucleus penetrates.

### **4 Role In Osteogenesis:**

The lysosomal enzymes degrade the osteoclast of the bone to the organic matrix. The ageing of cells and parthenogenetic development are also due to the lysosome's activity.

### **5 Lysosome Function Disorders:**

There are about 30 fairly rare disorders in humans that are due to defects in lysosomal function. These disorders are due to lysosomal storage problems or errors in the genetic codes.

Genetically driven disorders of the lysosomes can cause impaired platelet synthesis and hypopigmentation.

---

## **4.3 Transport From The Golgi Apparatus to Lysosomes**

---

Proteins, lipids and polysaccharides are transported from the Golgi apparatus to their final destinations through the secretory pathway. Proteins are sorted into

different kinds of transport vesicles, which bud from the *trans* Golgi network and deliver their contents to the appropriate cellular locations. Some proteins are carried from the Golgi apparatus to the plasma membrane by a constitutive secretory pathway and some proteins are transported to the cell surface by a distinct pathway of regulated secretion or are specifically targeted to other intracellular destinations, such as lysosomes in animal cells or vacuoles in yeast.

Proteins are sorted into the regulated secretory pathway in the *trans* Golgi network, where they are packaged into specialized secretory vesicles. These immature secretory vesicles are larger than the transport vesicles, often fuse with each other while further processing their protein contents. The sorting of proteins into the regulated secretory pathway appears to involve the recognition of signal patches shared by multiple proteins that enter this pathway.

The cisternal maturation model proposed for transport of proteins through the Golgi apparatus deals with the fact that the cisternae of the Golgi apparatus move by being built at the *cis* face and destroyed at the *trans* face. Vesicles from the endoplasmic reticulum fuse with each other to form a cisterna at the *cis* face, consequently this cisterna would appear to move through the Golgi stack when a new cisterna is formed at the *cis* face. This model is supported by the fact that structures larger than the transport vesicles, such as collagen rods, were observed microscopically to progress through the Golgi apparatus.

The vesicular transport model views the Golgi as a very stable organelle, divided into compartments in the *cis* to *trans* direction. Membrane bound carriers transport material between the endoplasmic reticulum and the different compartments of the Golgi. Experimental evidence includes the abundance of small vesicles also known as shuttle vesicles in proximity to the Golgi apparatus. To direct the vesicles, actin filaments connect packaging proteins to the membrane to ensure that they fuse with the correct compartment.

The cisternal maturation model and the vesicular transport model may actually work in conjunction with each other and sometimes referred to as the combined model.

The vesicles that leave the rough endoplasmic reticulum are transported to the *cis* face of the Golgi apparatus, where they fuse with the Golgi membrane and empty their contents into the lumen. Once inside the lumen, the molecules are modified, then sorted for transport to their next destinations. The Golgi apparatus tends to be larger and more numerous in cells that synthesise and

secrete large amounts of substances; for example, the plasma B cells and the antibody-secreting cells of the immune system have prominent Golgi complexes. Those proteins destined for areas of the cell other than either the endoplasmic reticulum or Golgi apparatus are moved towards the *trans* face, to a complex network of membranes and associated vesicles known as the trans-Golgi network (TGN). This area of the Golgi is the point at which proteins are sorted and shipped to their intended destinations by their placement into one of at least three different types of vesicles, depending upon the molecular marker they carry.

---

#### 4.4 Endocytosis and exocytosis

---

It is transport of large quantities of micromolecules, macromolecules and food particles through the membrane. It is accompanied by formation of transport or carrier vesicles. The latter are endocytotic and perform bulk transport inwardly. The phenomenon is called endocytosis. Endocytosis is of two types, pinocytosis and phagocytosis. Exocytic vesicle perform bulk transport outwardly. It is called exocytosis. Exocytosis performs secretion, excretion and ephagy.

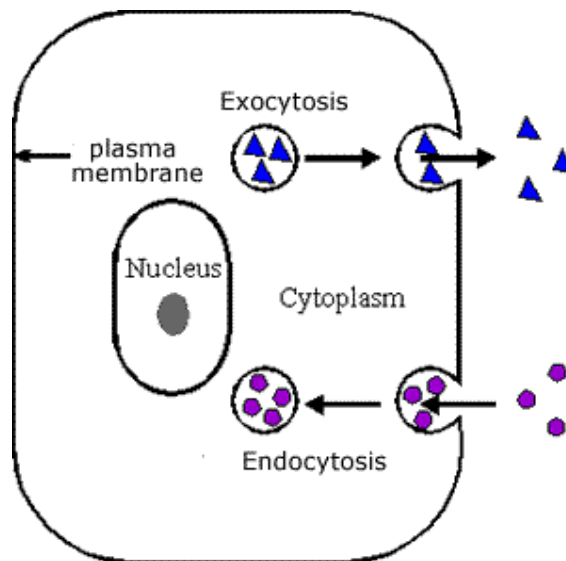

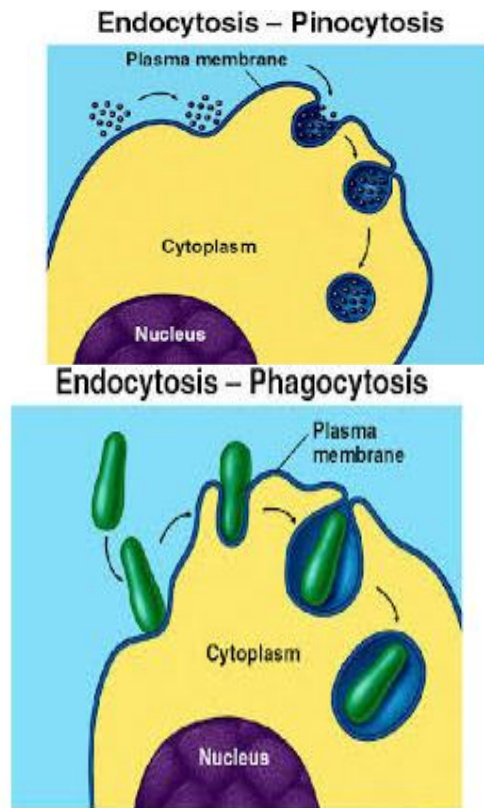

- (a) **Pinocytosis** : (Lewis, 1931). It is bulk intake of fluid, ions and molecules through development of small endocytotic vesicles of 100 – 200 nm in diameter. ATP,  $Ca^{2+}$ , fibrillar protein clathrin and contractile protein actin are required. Fluid-phase pinocytosis is also called cell drinking. It is generally nonselective. For ions and molecules the membrane has special receptor or adsorptive sites located in small pits. They perform adsorptive pinocytosis. After coming in contact with specific substance, the area of plasma membrane having adsorptive sites, invaginates and forms vesicle. The vesicle separates. It is called pinosome. Pinosome may burst in cytosol, come in contact with tonoplast and pass its contents into vacuole, form digestive vacuole with lysosome or deliver its contents to Golgi apparatus when it is called receptosome.
- (b) **Phagocytosis** : (Metchnikoff, 1883). It is cell eating or ingestion of large particles by living cells, e.g., white blood corpuscles (neutrophils, monocytes), Kupffer's cells of liver, reticular cells of spleen, histiocytes of connective tissues, macrophages, Amoeba and some other protists, feeding cells of sponges and coelentrates. Plasma membrane has receptors. As



soon as the food particle comes in contact with the receptor site, the edges of the latter evaginate, form a vesicle which pinches off as phagosome.

One or more lysosomes fuse with a phagosome, form digestive vacuole or food vacuole. Digestion occurs inside the vacuole. The digested substances diffuse out, while the residual vacuole passes out, comes in contact with plasma membrane for throwing out its contents through exocytosis or ephagy.

---

## 4.5 Microbodies

---

### Introduction

Microbodies are single membrane bounded small spherical or oval organelles, which take part in oxidation reactions other than those of respiration. They can only be seen by electron microscope. Microbodies possess a crystalline core and granules matrix. They are following types :-

(1) **Glyoxysomes**

(i) **Discovery** : These were discovered by Beevers in 1961 and Briedenbach in 1967.

(ii) **Occurrence** : These are found in fungi, some protists and germinating seeds especially in germinating fatty seeds where insoluble lipid food reserves must be turned into soluble sugars.

Animals cannot execute this conversion because they do not possess glyoxylate enzymes.

(iii) **Shape, size and structure** : These are spherical in shape, about 0.5-1  $\mu\text{m}$  in size, they contain enzymes of metabolism of glycolic acid via glyoxylate cycle and bounded by a unit membrane. These are also contain enzymes for  $\beta$ -oxidation of fatty acids.

(iv) **Functions** : The main function of glyoxysomes is conversion of fats into carbohydrates.

(2) **Peroxisomes (Uricosomes)**

(i) **Discovery** : These were first discovered by J. Rhodin (1954) in the cells of mouse kidney with the help of electron microscope, and were called microbodies. De Duve (1965) isolated certain sac like organelles from various types of animals and plants. These were called

peroxisomes because these contain peroxide producing enzymes (oxidases) and peroxide destroying enzymes (catalases).

(ii) **Occurrence** : These are found in photosynthetic cells of plants. In animals peroxisomes are abundant in the liver and kidney cells of vertebrates. They are also found in other organs like brain, small intestine, testis and adrenal cortex. They also occur in invertebrates and protozoans e.g., Paramecium.

(iii) **Shape, size and structure** : These are spherical in shape, about 1.5  $\mu\text{m}$  in size. They are bounded by a single unit membrane. They contains granular contents condensing in the centre. Their membrane is permeable to amino acids, uric acids, etc. They contain four enzymes of  $\text{H}_2\text{O}_2$  metabolism. The enzymes urate oxidase, d-amino oxidase,  $\alpha$ -hydroxy acid oxidase produce  $\text{H}_2\text{O}_2$  whereas the catalases plays a significant protective role because  $\text{H}_2\text{O}_2$  is toxic for cells.

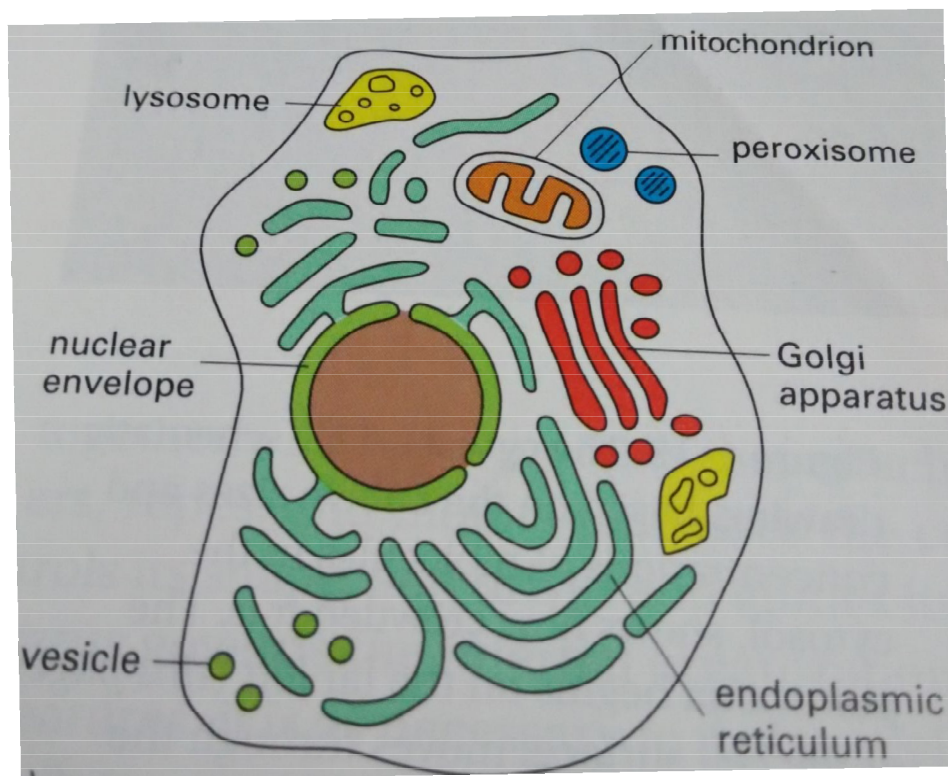
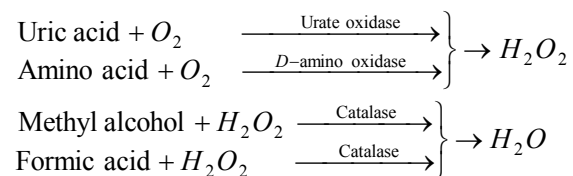

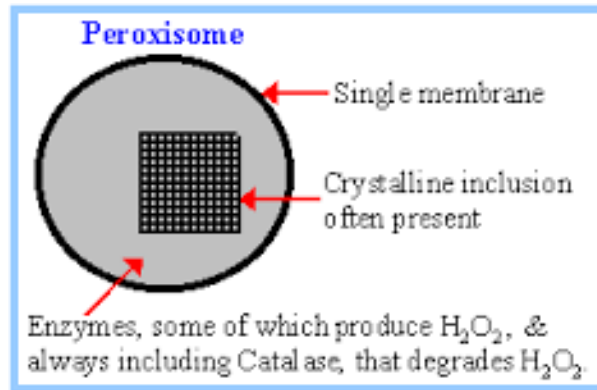

(v) **Function** : These are involved in the formation and degrading of  $H_2O_2$ . Plant peroxisomes are also involved in photorespiration. In which glycolic acid oxidase enzyme oxidises the glycolic acid to glyoxylic acid. In case of plants peroxisomes is also known as glyoxisomes.

### (3) Sphaerosomes

(i) **Discovery** : These were first observed by Hanstein (1880) but discovered by Perner (1953). Term sphaerosomes was given by Dangeard.

(ii) **Occurrence** : These are found in all the plant cells which involves in the synthesis and storage of lipids i.e. endosperm and cotyledon.

(iii) **Shape, size and structure** : These are spherical or oval in shape about 0.5-2.5  $\mu\text{m}$  in diameter. They contain hydrolytic enzymes like protease, ribonuclease, phosphatase, esterase etc. They are bounded by a single unit membrane.

(iv) **Function** : The main function of sphaerosomes is to help in lipid metabolism. These are also known as plant lysosomes.

---

## 4.7 Glossary

---

- **Golgi Complex**; Membrane bound organelle in eukaryotic cells, where the proteins and lipids made in the ER are modified and sorted.

- Lysosome; Membrane bound organelle containing digestive enzymes. Lysosomal enzymes are active at an acid pH.
- **Endocytosis**; Engulfment of material into a cell by invagination of the plasma membrane leading to formation of a membrane bounded vesicle. Pinocytosis (cell drinking) and phagocytosis (cell eating).
- **Glyoxysome** ; Single membrane bounded microbody responsible for conversion of fats into carbohydrates in fungi, some protist and germinating seeds.
- **Peroxisome** ; Small single membrane bounded organelle that utilises molecular oxygen to oxidize organic molecules. It contains the enzymes that produce hydrogen peroxide.
- **Spherosome**; Single membrane bounded spherical microbody present in plant cells involved in synthesis and storage of lipids. It is responsible for synthesis of cutin and wax.

---

## 4.8 Self Learning Exercise

---

### Section A (Very Short Answer Type)

1. Name the scientist who discovered the golgi complex.
2. GERL stands for -----.
3. Name different types of lysosomes .
4. Which cell organelle stores hydrolase enzyme.
5. The process of cell drinking is also known as-----.
6. Metchnikoff discovered -----.
7. ----- utilizes the molecular oxygen to oxidize organic molecules.
8. Which microbody is responsible for cutin formation.  
(Camillo golgi, Golgi complex-endoplasmic reticulum-lysosome, Primary lysosome ,secondary lysosome, residual lysosome & autophagic vacuole, Lysosomes, Pinocytosis, Phagocytosis, Peroxisomes & Spherosomes )

### Section B ( Short Answer Type)

1. Where do you find the golgi complex?
2. Draw a labeled diagram of golgi complex.

3. Why lysosomes often described as suicidal bags ?
4. What is exocytosis ?
5. What is the role of peroxysome in cell function ?

#### **Section C ( Long Answer Type)**

1. Describe the vesicular transportation by golgi complex.
2. Discuss the functions of the golgi complex.
3. Mention different types of lysosomes.
4. Describe the process of endocytosis in the cell.
5. Describe the various types of the microbodies and their functions.

---

### **4.9 References**

---

- Campbell, Essential Biology (Abridged), Cambridge.
- Starr & Taggart, Biology : The Unity and Diversity of Life.
- Lehninger : Principles of Biochemistry.
- Lubert Stinger : Biochemistry
- Donald Voet & Judith.G.Voet – Biochemistry.
- Murary : Harper’s Biochemistry
- Geoffry.M Cooper and Robert.E.Hansmann : The Cell
- McDaneld TG. MicroRNA: Mechanism of gene regulation and application to livestock.J. Anim. Sci. 2009. 87(E. Suppl.):E21–E28.
- Watson et al. Molecular Biology of the Gene, Sixth Edition, 2008. Watson JD, Baker TA, Bell SP, Gann A, Levine M, Losick R. (Benjamin Cummings, San Francisco).

## Unit - 5

---

### Energy transducers and other organelles

---

#### Structure of the Unit

- 5.0 Objective
- 5.1 Introduction
- 5.2 History of Mitochondria
- 5.3 Structure of Mitochondria
- 5.4 Dysfunction of mitochondria
- 5.5 Role of Mitochondria in Energy Transduction
  - 5.5.1 Sequence of electron transport
  - 5.5.2 Mechanism of ATP synthesis
- 5.6 Summary
- 5.7 Glossary
- 5.8 Self-Learning Exercise
- 5.9 References

---

#### 5.0 Objective

---

After going through this unit you will be able to understand

- What is Energy transduction?
- Structure of mitochondria
- Where ATP are formed?
- Role of Mitochondria
- Function of Mitochondria
- ATP generation in Mitochondria
- Chemo osmotic coupling

---

#### 5.1 Introduction

---

The free energy released upon the enzymatic hydrolysis of adenosine triphosphate (ATP) is the main source of energy for the functioning of the living cell and all multicellular organisms. The majority of ATP molecules are formed by proton ATP synthases, which are the smallest macromolecular

electric motors in Nature. The molecular machine is a macromolecular structure, typically of natural origin that converts chemical energy into the energy of directional motion of macromolecules or their fragments, transfers molecules and ions across biological membranes, and so on.

The membrane that is used to produce ATP in procaryotes is the plasma membrane. But in eukaryotic cells, the plasma membrane is reserved for the transport processes. Instead, the specialized membranes inside energy-converting organelles are employed for the production of ATP. The membrane-enclosed organelles are mitochondria, which are present in the cells of virtually all eukaryotic organisms (including fungi, animals, and plants), and chloroplasts (occurs only in plants). In electron micrographs the most striking morphological feature of mitochondria and chloroplasts is that they contain large amount of internal membrane. This internal membrane provides the framework for an elaborate set of electron-transport processes that produce most of the cell's ATP.

Mitochondria have captured the interest of biochemists for more than 50 years. They have been studied intensively in the past decades. Mitochondria play a central role in cellular energy metabolism that attracted the attention of cell physiologists and physiological chemists, and led to Nobel Prizewinning work such as Peter Mitchell's chemiosmotic theory. Since the days of classical physiological chemistry, bioenergetics research has gone a long way. Contributions from structural biology, biophysics and mathematical biology increase our still incomplete understanding of mitochondrial metabolism and its regulation in ever more detail.

---

## **5.2 History of Mitochondria**

---

The first observations of intracellular structures that probably represent mitochondria were published in the 1840s. The term "mitochondria" was coined by Carl Benda in 1898. Richard Altmann, in 1894, established them as cell organelles and called them "bioblasts". Friedrich Meves, in 1904, made the first recorded observation of mitochondria in plants (*Nymphaea alba*). In 1913 particles from extracts of guinea-pig liver were linked to respiration by Otto Heinrich Warburg, which he called "grana". In 1939, experiments using minced muscle cells demonstrated that one oxygen atom can form two adenosine triphosphate molecules, and, in 1941, the concept of phosphate bonds being a form of energy in cellular metabolism was developed by Fritz Albert Lipmann. In the following years, the mechanism behind cellular respiration was further

elaborated, although its link to the mitochondria was not known. The introduction of tissue fractionation by Albert Claude allowed mitochondria to be isolated from other cell fractions and biochemical analysis to be conducted on them alone. In 1946, he concluded that cytochrome oxidase and other enzymes responsible for the respiratory chain were isolated to the mitochondria. Over time, the fractionation method was tweaked, improving the quality of the mitochondria isolated, and other elements of cell respiration were determined to occur in the mitochondria. The first high-resolution micrographs appeared in 1952, this led to a more detailed analysis of the structure of the mitochondria, including confirmation that they were surrounded by a membrane. It also showed a second membrane inside the mitochondria that folded up in ridges dividing up the inner chamber and that the size and shape of the mitochondria varied from cell to cell. The popular term "powerhouse of the cell" was coined by Philip Siekevitz in 1957. In 1968, methods were developed for mapping the mitochondrial genes, with the genetic and physical map of yeast mitochondria being completed in 1976.

---

### **5.3 Structure of mitochondria**

---

Mitochondria are about 0.5–1  $\mu\text{m}$  in diameter and up to 7  $\mu\text{m}$  long. Their shape and number per cell depends on the particular tissue. They may appear as spheres, rods or filamentous bodies, but the general architecture is the same in all species. The double-membraned mitochondrion can be loosely described as a large wrinkled bag packed inside of a smaller, unwrinkled bag. The two membranes create distinct compartments within the organelle, and are themselves very different in structure and in function.

The major component of mitochondrion are:

1. Outer Membrane
2. Inner Membrane
3. Matrix
  1. Outer Membrane: The outer membrane is a relatively simple phospholipid bilayer, containing protein structures called porins which render it permeable to molecules of about 10 kilodaltons or less (the size of the smallest proteins). Ions, nutrient molecules, ATP, ADP, etc. can pass through the outer membrane with ease.
  2. Inner Membrane: The inner membrane is freely permeable only to oxygen, carbon dioxide, and water. Its structure is highly complex,



including all of the complexes of the electron transport system, the ATP synthetase complex, and transport proteins. The wrinkles, or folds, are organized into lamillae (layers), called the cristae (singular: crista). The cristae greatly increase the total surface area of the inner membrane. The larger surface area makes room for many more of the above-named structures than if the inner membrane were shaped like the outer membrane.

The membranes create two compartment with the intermembrane space, it is the region between the inner and outer membranes. It has an important role in the primary function of mitochondria (oxidative phosphorylation).

3. Matrix: The matrix is a complex mixture of enzymes that are important for the synthesis of ATP molecules, special mitochondrial ribosomes, tRNAs and the mitochondrial DNA. Besides these, it has oxygen, carbon dioxide and other recyclable intermediates.

Mitochondria are sometimes described as "the powerhouse of the cell" because they generate most of the cell's supply of adenosine triphosphate (ATP), used as a source of chemical energy. In addition to supplying cellular energy, mitochondria are involved in other tasks such as signaling, cellular differentiation, cell death, as well as maintaining the control of the cell cycle and cell growth.

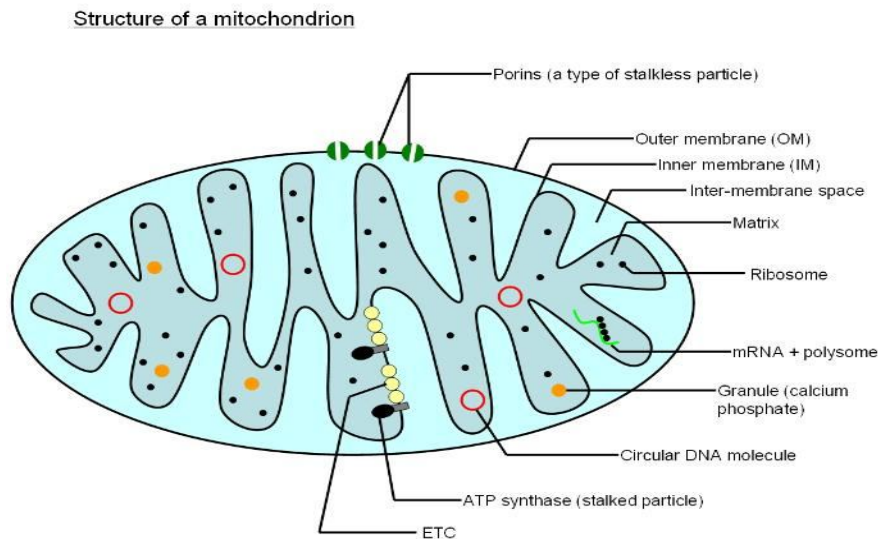

**Figure1: Structure of Mitochondria Source:**  
[ronodon.com/BioTech/Respiration.html](http://ronodon.com/BioTech/Respiration.html)

---

### 5.3 Function of Mitochondria

---

The major function of the mitochondria are vary in different cell types but major role of mitochondrion in most of animals are as follows:

1. The most important function of the mitochondria is to produce energy. The food that we eat is broken into simpler molecules. These are sent to the mitochondrion where they are further processed to produce charged molecules that combine with oxygen and produce ATP molecules. This entire process is known as oxidative phosphorylation.

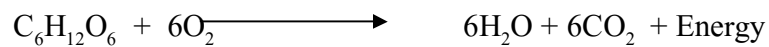

2. Another important function of mitochondria is to store calcium ion and whenever required within various compartments of the cell it provide calcium ions in appropriate quantity.
3. Mitochondria also help in the building of certain parts of the blood, and hormones like testosterone and estrogen.
4. Mitochondria in the liver cells have enzymes that detoxify ammonia.
5. Mitochondria play an important role in the process of programmed cell death. Abnormal cell death due to mitochondrial dysfunction can affect the function of the organ.

---

### 5.4 Dysfunction of mitochondria

---

Dysfunction of mitochondria can affect the production of cell-specific products that are essential for proper cell functioning and energy production. This can eventually lead to cell death and failure of the organ system. It can even prove to be fatal in some cases. When the ability of the mitochondria to produce energy is reduced due to certain defects (a genetic mutation in either the mitochondrial DNA or the nuclear DNA), the condition is described as 'mitochondrial disease'. Reduced production of energy can lead to dysfunction of brain, vision problems, weak muscles, restricted movement of limbs, etc. It can destroy heart health, digestive health of the person. Any person at any age can have mitochondrial disease. Some of the symptoms are recurring infections (weak immune system), reduced capacity of the heart, strokes, seizures, muscle fatigue, gastrointestinal problems, liver problems, diabetes, obesity, blindness and deafness. Various environmental factors or certain medicines can affect the function of mitochondria adversely.

---

## 5.5 Role of Mitochondria in Energy Transduction

---

The oxidation of glucose carbon atoms is carried out in glycolysis and the citric acid cycle, and the produced protons and electrons are stored in NADH and FADH<sub>2</sub> molecules. The electrons from NADH and FADH<sub>2</sub> are injected into the electron-transport chain in the inner membrane of mitochondrion. When the electron passes through the electron-transport chain into the O<sub>2</sub> reduction chamber (a protein complex), the protons in the mitochondrial matrix are expelled to the intermembrane space so as to generate the pH gradient between the matrix and the intermembrane space of a mitochondrion. The free energy stored in the resulting pH gradient drives the synthesis of ATP from ADP and Pi. This process is called oxidative phosphorylation.

Oxidation of NADH by O<sub>2</sub> (2e<sup>-</sup> transfer) under standard biochemical condition releases 218 kJ of free energy, and an ATP synthesis (ADP + Pi → ATP) requires 30.5 kJ/mol free energy. Thus, several moles of ATP can be synthesized from 218 kJ of free energy of (½O<sub>2</sub> + NADH → NAD<sup>+</sup> + H<sub>2</sub>O) reaction. Actually, 218 kJ free energy is broken up into three packets. Each of packets is coupled with one ATP synthesis.

For the explanation of oxidative phosphorylation and electron transport chain, Chemiosmotic hypothesis was proposed by Peter Mitchell (1961). According to this theory the free energy of electron transport is conserved by pumping H<sup>+</sup> (proton) from the mitochondrial matrix to the intermembrane space so as to create an electrochemical H<sup>+</sup> gradient across the inner mitochondrial membrane. The electrochemical potential of this gradient is harnessed to synthesize ATP.

### 5.5.1 Sequence of electron transport

The electrons of NADH are injected into the Complex I (NADH-Coenzyme Q reductase), which is a transmembrane multisubunit protein complex. Complex I is probably the largest protein component in mitochondria. The received electrons are then passed to FMN and to various Fe-S clusters, and then to CoQ.

The electrons of FADH<sub>2</sub> are transferred into the Complex II (Succinate-Coenzyme Q Reductase). It passes electrons from succinate to CoQ. Complex II contains succinate dehydrogenase, three hydrophobic subunit and also contains covalently bound FAD, one [4Fe-4S], one [2Fe-2S], one cytochrome

b560. The bound FAD is reduced to FADH<sub>2</sub> in the citric acid cycle by the oxidation of succinate to fumarate.

Electrons are then carried by a CoQ (coenzyme Q (ubiquinone)) to the Complex III (Coenzyme Q-Cytochrome c Reductase). It passes electron from reduced CoQ to cytochrome c. Complex III contains two b-cytochromes (bL (566 nm) and bH (562 nm)), one cytochrome c1, and one[2Fe-2S] cluster.

The electrons are further transferred to the Complex IV (Cytochrome c oxidase) which is a O<sub>2</sub> reduction chamber. It catalyzes one-electron oxidations by four consecutive reduced cytochrome c molecules and concomitant four-electron reduction of one O<sub>2</sub> molecule.

When the electron passes through each Complex (Complex I, III and IV), an amount of H<sup>+</sup> is pumped out from the mitochondrial matrix to the inner membrane space, which can produce one mole of ATP.

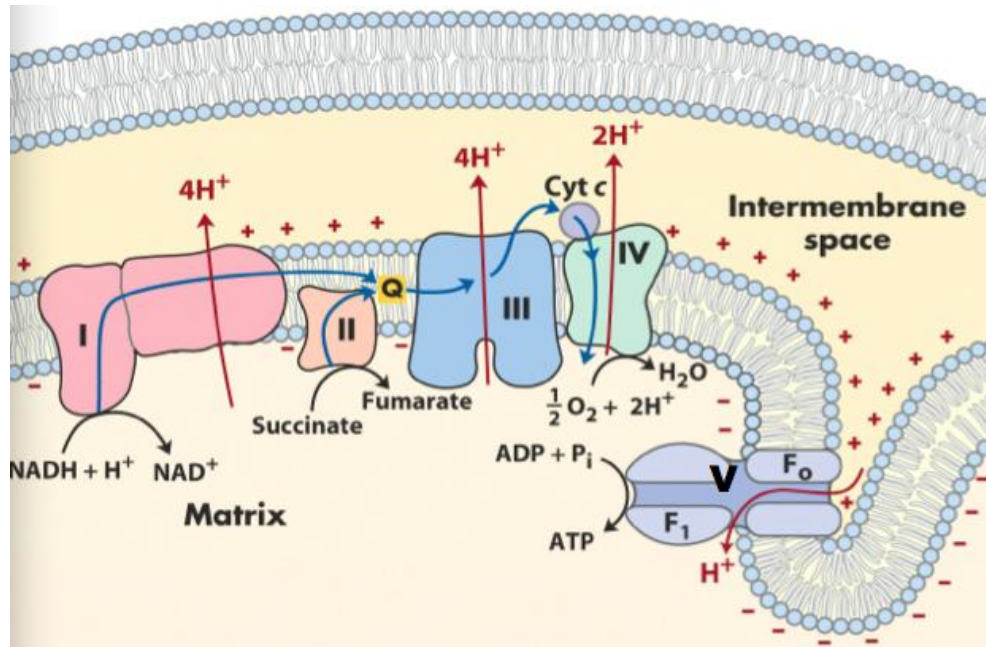
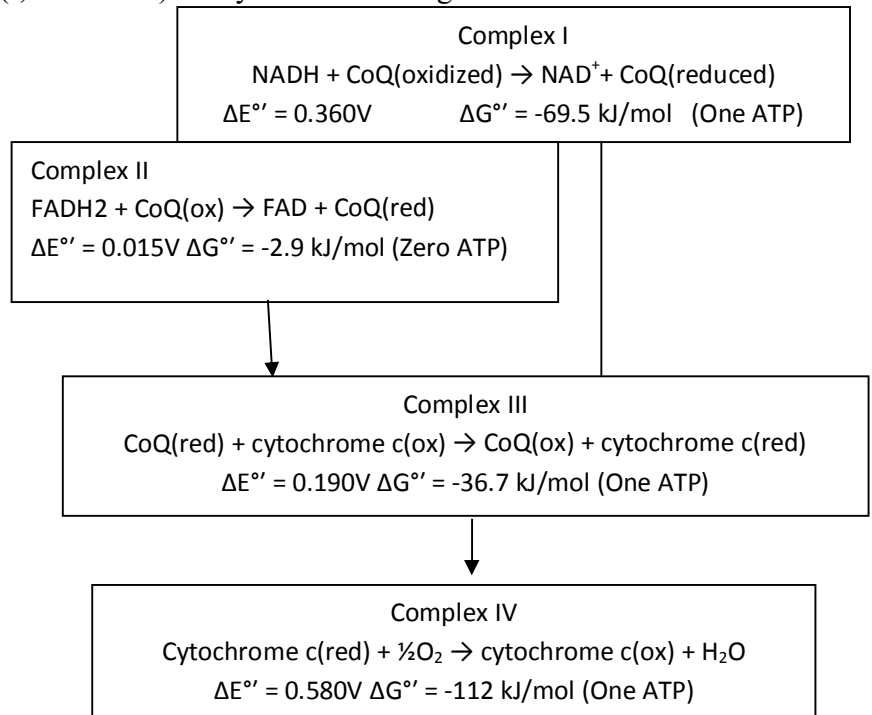

Fig:2 The electrons of NADH are injected into the Complex I The received electrons are then passed to to CoQ. The electrons of FADH<sub>2</sub> are transferred into the Complex II, it also passes electrons from succinate to CoQ. The electrons are then move through complex III and complex IV and develop epectric potential and proton motive force and generate ATP via ATPase.

$\Delta G$  of electron transport is conserved by pumping H<sup>+</sup> from mitochondrial matrix to intermembrane space, creating electrochemical H<sup>+</sup> gradient across innermembrane, which drive ATP synthesis. The respiratory chain is arranged in three loops corresponding to the three coupling sites. By a special vectorial

arrangement of the electron-carrying molecules, an  $H^+$  adsorbing reaction occurs on the inside surface of the inner mitochondrial membrane (i.e., the surface facing the matrix). A concomitant  $H^+$ -releasing reaction occurs on the outside surface of that membrane. As a result, an  $H^+$  gradient develops, with the higher concentration of  $H^+$  on the outside of the inner membrane. A reversible ATPase complex on the mitochondrial inner membrane is located in a region impermeable to water but accessible to  $OH^-$  from one side of the inner membrane and accessible to  $H^+$  from the other side. Thus ATP hydrolysis would be reversibly coupled to the translocation of  $OH^-$  ions across the system with a stoichiometry of one  $OH^-$  translocated per ATP molecule hydrolyzed. The proton gradient provides energy for synthesis of ATP.

Protein complexes (I, III and IV) catalyze the following reactions:



**5.6.2 Mechanism of ATP synthesis:** ATP is synthesized by proton-translocating ATP synthase (proton pumping ATPase, F<sub>1</sub>F<sub>0</sub>-ATPase). It is located in the inner mitochondrial membrane. Proton-translocating ATP synthase is a multi-subunit transmembrane protein. It has two major substructures, i.e., F<sub>1</sub> and F<sub>0</sub>. F<sub>1</sub> is water soluble peripheral membrane protein composed of 9 subunits ( $\alpha\beta\gamma\delta\epsilon$ ), and F<sub>0</sub> is water insoluble transmembrane protein composed of 10-12 subunits. In between the F<sub>1</sub> and F<sub>0</sub> stalk is present

which contains oligomycin-sensitivity-cofactors protein (OSCP) and coupling factor 6 (CF6).

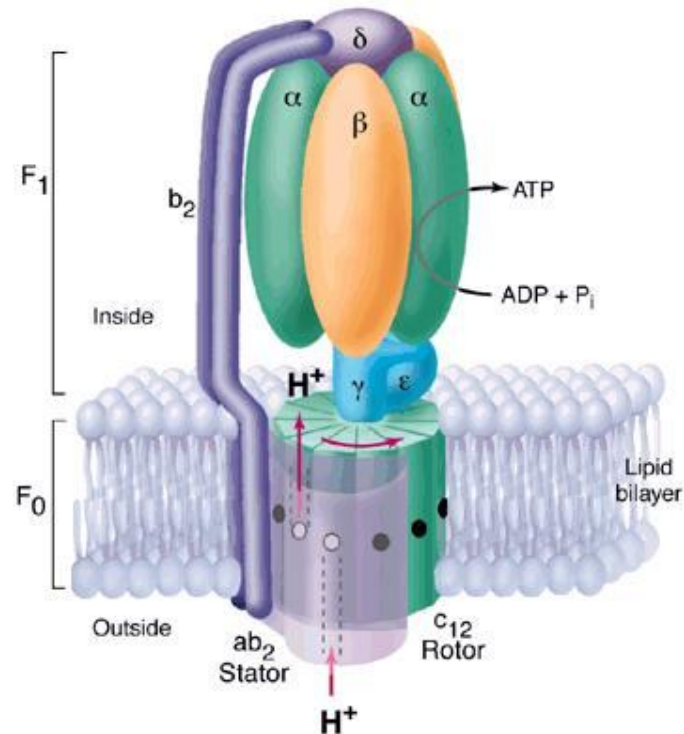

**Fig. 3 Structure of ATPase.**

Catalytic sites on  $\beta$  subunits assume different conformation every 120° turn. One of them binds ADP and P<sub>i</sub> and another one catalyses addition of P<sub>i</sub> to ADP and one of them releases ATP.

---

## 5.6 Summary

---

The mitochondria is called as powerhouse of cell as it generates ATP for the functioning of cell. It is double membrane bound organelle. During respiration krebs cycle take place in the matrix; electron transport takes place on the inner membrane; a gradient is maintained across the inner membrane; ATP synthesis takes place in the matrix as protons cross the inner membrane from the intermembrane space. Krebs reactions transfer energy from the progressive oxidation of substrates to two types of energy carriers, NAD and FAD. Energy carriers donate electrons and free energy to the electron transport system (ETS). Each successive carrier in the ETS, when reduced, carries less available free energy than the one upstream. Electron transport cannot take place without pumping protons out of the matrix. Proton pumping produces a chemiosmotic

gradient that in turn restricts the rate of electron transport. The most important process that exploits the gradient is ATP synthesis.

---

## 5.7 Glossary

---

- **ATP:** Adenosine triphosphate
- **ADP:** Adenosine diphosphate
- **NADH:** Nicotinamide adenine dehydrogenase

---

## 5.8 Self-Learning Exercise

---

### Section -A (Very Short Answer Type)

1. Who coined the term mitochondria?  
(a) Benda      (b) Altmann      (c) Brown      (d) None of above
2. Oxidative metabolism is carried out \_\_\_\_ of mitochondria  
(a) in the intermembrane space      (c) in the inside of the outer membrane  
(b) on the surface of the inner membrane      (d) in the matrix
3. Mitochondrial enzymes for oxidative metabolism are  
(a) on or within the surface of cristae      (c) in the matrix  
(b) located on the outer membrane      (d) floating freely in intermembrane space
4. ATP is synthesized by proton-translocating.....
5. Mitochondria play a central role in cellular ..... metabolism
6. ....is the main source of energy for the functioning of the living cell and all multicellular organisms.

### Section -B (Short Answer Type)

1. Draw well labeled diagram of mitochondria
2. Write the functions of mitochondria
3. What do you understand with ATP and its role in human cell
4. Where ATP are formed in cell?

### Section -C (Long Answer Type)

1. Discuss in detail about electron transport chain.
2. What do you understand with chemo osmotic coupling?
3. How ATP are generated in mitochondria

4. Discuss in detail about the structure of mitochondria.

**Answer Key of Section-A**

1. a
2. a
3. a
4. ATP synthase
5. energy

---

**5.9 References**

---

- Molecular Biology of Cell, Alberts B et al. Garland Publishers, (2001)
- Molecular Cell Biology, Lodish et al. Scientific American Books (1995)



# Unit - 6

---

## Cell Signalling

---

### Structure of the Unit

- 6.0 Objective
- 6.1 Introduction
- 6.2 Types of Cell Signalling
- 6.3 Cell signalling Molecules and Their mechanism of action
- 6.4 Cell surface receptors and their mechanism of action
- 6.5 Major Pathways of Cell Signalling
  - 6.5.1 The cAMP pathway
  - 6.5.2 The cGMP pathway
  - 6.5.3 Phospholipase C-Ca<sup>2+</sup> pathway
  - 6.5.4 NF- $\kappa$ B Transcription factor pathway
  - 6.5.5 Ca<sup>2+</sup> - Calmodulin pathway
  - 6.5.6 MAP Kinase pathway
  - 6.5.7 JAK-STAT pathway
- 6.6 Programmed Cell Death
- 6.7 Summary
- 6.8 Exercise
- 6.9 Glossary
- 6.10 Further readings

---

### 6.0 Objective

---

After reading this unit you will come to know about how cells receive the signal ? What are the molecules and mechanisms by which cells communicate the messages to other cells. You will also read the concept of programmed cell death in this unit.

---

### 6.1 Introduction

---

Cells respond to extracellular signals produced by other cells or by themselves. This mechanism, called cell signalling, allows cell-cell communication and is necessary for the functional regulation and integration of multi-cellular organisms. We will discuss in this unit the basis for understanding normal cell function. Signalling molecules are either secreted or expressed at the cell

surface of cell. Signalling molecules can bind to receptors on the surface of another cell or the same cell.

Different type of signalling molecules transmit information in multi-cellular organisms, and their mechanisms of action on their cells can be diverse. Some signalling molecules can act on the cell surface after binding to cell surface receptors; others can cross the plasma membrane and bind on intracellular receptors in the cytoplasm and nucleus.

When a signalling molecule binds to its receptor, it initiates a cascade of intracellular reactions to regulate critical functions such as cell proliferation, differentiation, movement, metabolism, and behaviour. Because of their critical role in the control of normal cell growth and differentiation, signalling molecules have acquired significant relevance in cancer research.

---

## 6.2 Types of Cell Signalling

---

Five major types of cell-cell signalling are considered:

1. **Endocrine cell signalling** involves a signalling molecule, called a **hormone**, secreted by an **endocrine cell and transported through the circulation to act on distant target** cells. As example is the steroid hormone testosterone produced in the testes that stimulate the development and maintenance of the male reproductive tract.
2. **Paracrine Cell signalling** is mediated by a signalling molecule acting locally to regulate the behaviour of a nearby cell. An example is the action neurotransmitters produced by nerve cells and released at a synapse.
3. **Autocrine cell signalling** is defined by cells **responding to signalling molecules that they themselves produce**. A classic example is the response of cells of the immune system to foreign antigens or growth factors that trigger their own proliferation and differentiation. Abnormal autocrine signalling leads to the unregulated growth of cancer cells.
4. **Neurotransmitter cell signalling** a specific form of paracrine signalling.
5. **Neuroendocriner cell signalling**, a specific form of endocrine signalling.

---

## 6.3 Cell signalling molecules and their mechanism of action

---

Cell signalling molecules exert their action after binding to receptors expressed by their target cells, can determine either a negative or positive feedback action to regulate the release of the targeting hormone.

Cell receptors can be expressed on the cell surface of the target cells. Some receptors are intracellular proteins in the cytosol or the nucleus of target cells. Intracellular receptors require that the signalling molecules diffuse across the plasma membrane.

Steroid hormones belong to this class of signalling molecules. Steroid hormones are synthesized from cholesterol and include testosterone, estrogen, progesterone, and corticosteroids.

Testosterone, estrogen, and progesterone are sex steroids and are produced by the gonads. Corticosteroids are produced by the cortex of the adrenal gland and include two major classes: glucocorticoids, which stimulate the production of glucose, and mineralocorticoids, which act on the kidney to regulate water and salt balance.

There are three cell signalling molecules that are structurally and functionally distinct from steroids but act on target cells by binding to intracellular receptors after entering the cell by diffusion across the plasma membrane. They include thyroid hormone (produced in the thyroid gland to regulate development and metabolism), Vitamin D (regulates calcium metabolism and bone growth), and retinoids (synthesized from vitamin A to regulate development).

Steroid receptors are members of the steroid receptor super family. They act as transcription factors through their DNA binding domains, which have transcription activation or repression functions. Steroid hormones and related molecules can therefore regulate gene expression.

In the androgen insensitivity syndrome (also known as the testicular feminization syndrome [Tfm]) there is a mutation in the gene expressing the testosterone receptor such that the receptor cannot bind the hormone, and hence the cells do not respond to the hormone. Although genetically male, the individual develops the secondary sexual characteristics of a female.

Nitric oxide is also a signalling molecule. It is a simple gas synthesized from the amino acid arginine by the enzyme nitric oxide synthase. It acts as a paracrine signalling molecule in the nervous, immune, and circulatory systems. Like steroid hormones, nitric oxide can diffuse across the plasma membrane of its target cells. Unlike steroids, nitric oxide does not bind to an intracellular receptor to regulate transcription. Instead, it regulates the activity of intracellular target enzymes.

Nitric oxide increases the activity of the second messenger cyclic guanosine monophosphate in smooth muscle cells, which then causes cell muscle relaxation and blood vessel dilation. Nitroglycerin, a pharmacologic agent used

in the treatment of heart disease, is converted to nitric oxide, which increases heart blood flow by dilation of the coronary blood vessels.

---

## 6.4 Cell Surface Receptors and their mechanism of action

---

When a cell signalling molecule binds to a specific receptor, it activates a series of intracellular targets located downstream of the receptor. Several molecules associated with receptors have been identified:

1. G protein-coupled receptors (guanine nucleotide-binding proteins): Members of a large family of G proteins (more than 1000 proteins) are present at the inner leaflet of the plasma membrane. When a signalling molecule or receptor ligand binds to the extracellular portion of a cell surface receptor, its cytosolic domain undergoes a conformational change that enables binding of the receptor to a G protein. This contact activates the G protein, which then dissociates from the receptor and triggers an intracellular signal to an enzyme or ion channel.
2. Tyrosine kinases as receptor proteins: These surface receptors are themselves enzymes that phosphorylate substrate proteins on tyrosine residues. EGF, NGF, PDGF, insulin, and several growth factors are receptor protein tyrosine kinases. Most of the receptor protein tyrosine kinases consist of single polypeptides, although the insulin receptor and other growth factors consist of a pair of polypeptide chains. Binding of a ligand (a growth factor) to the extracellular domain of these receptors induces receptor dimerization that results in receptor autophosphorylation (the two polypeptide chains phosphorylate one another). The autophosphorylation of these receptors determines the binding of the tyrosine kinase domain to downstream signalling molecules. Downstream signalling molecules bind to phosphotyrosine residues through domains called SH2 domains (for Sre homology2). Sre (for sarcoma) is a gene present in the tumor-producing Rous sarcoma virus and encodes a protein that function as a protein tyrosine kinase.
3. Cytokine receptors: This family of receptors stimulates intracellular protein tyrosine kinases, which are not intrinsic components of the receptor. A growth factor ligand induces the dimerization and cross-phosphorylation of the associated tyrosine kinases. Activated kinases phosphorylate the receptors, providing binding sites for downstream signalling molecules that contain the SH2 domain.
4. Receptors linked to other enzymes (protein tyrosine phosphatases and protein serine and threonine kinases): Some receptors associate with

protein tyrosine phosphatases to remove phosphate groups from phosphotyrosine residues. Therefore, they regulate the effect of protein tyrosine kinases by arresting signals initiated by protein tyrosine phosphorylation.

Members of the transforming growth factor- $\beta$  (TGF- $\beta$ ) family are protein kinases that phosphorylate serine and threonine residues (rather than tyrosine). TGF- $\beta$  inhibits the proliferation of their target cells.

---

## 6.5 Major pathways of Intracellular Cell Signalling

---

Upon ligand binding, most cell surface receptors stimulate intracellular target enzymes to transmit and amplify a signal. An amplified signal can be propagated to the nucleus to regulate gene expression in response to an external cell stimulus.

The major intracellular signalling pathways include the cAMP and cGMP pathways, the phospholipase C- $\text{Ca}^{2+}$  pathway, the NF- $\kappa\text{B}$  (for nuclear factor involved in the transcription of the  $\kappa$  light chain gene in  $\text{B}$  lymphocytes) transcription factor pathway, the  $\text{Ca}^{2+}$ -calmodulin pathway, the MAP (for mitogen-activated protein) kinase pathway, and the JAK-STAT (for signal transducers and activators of transcription) pathway.

### 6.5.1 The cAMP pathway

The intracellular signalling pathway mediated by cAMP was discovered in 1958 by Earl Sutherland while studying the action of epinephrine, a hormone that breaks down glycogen into glucose before muscle contraction.

When epinephrine binds to its receptor, there is an increase in the intracellular concentration of cAMP. cAMP is formed from adenosine triphosphate (ATP) by the action of the enzyme adenylyl cyclase and degraded to adenosine monophosphate (AMP) by the enzyme cAMP phosphodiesterase. This mechanism led to the concept of a first messenger mediating a cell-signalling effect by a second messenger, cAMP. The epinephrine receptor is linked to adenylyl cyclase by G protein, which stimulates cyclase activity upon epinephrine binding.

The intracellular signalling effects of cAMP (Figure 6.1) are mediated by the enzyme cAMP-dependent protein kinase (or protein kinase A). In its inactive form, protein kinase A is a tetramer composed of two regulatory subunits (to which cAMP-binds) and two catalytic subunits. Binding of cAMP results in the dissociation of the catalytic subunits. Free catalytic subunits can phosphorylate serine residues on target proteins.

In the epinephrine-dependent regulation of glycogen metabolism, protein kinase A phosphorylates two enzymes:

1. **Phosphorylase kinase**, which in turn phosphorylates glycogen phosphorylase to break down glycogen into glucose-1-phosphate.
2. **Glycogen synthase**, which is involved in the synthesis of glycogen. Phosphorylation of glycogen synthase prevents the synthesis of glycogen.

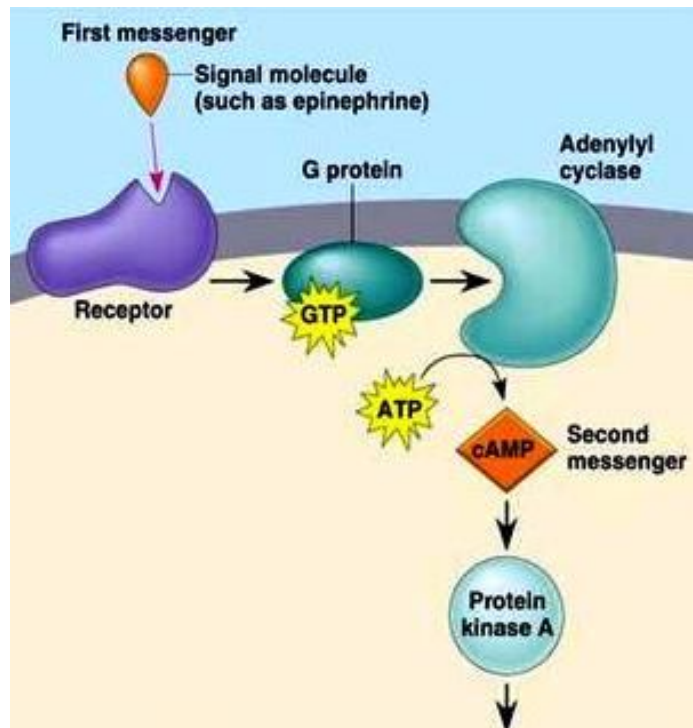

Figure: 6.1: CAMP Pathway

### 6.5.2 The cGMP pathway

cGMP is also a second messenger. It is produced from guanosine triphosphate (GTP) by guanylate cyclase and degraded to GMP by a phosphodiesterase. Guanylate cyclases are activated by nitric oxide and peptide signalling molecules. (Figure 6.2)

The best characterized role of cGMP is in photoreceptor rod cells of the retina, where it converts light signals to nerve impulses.

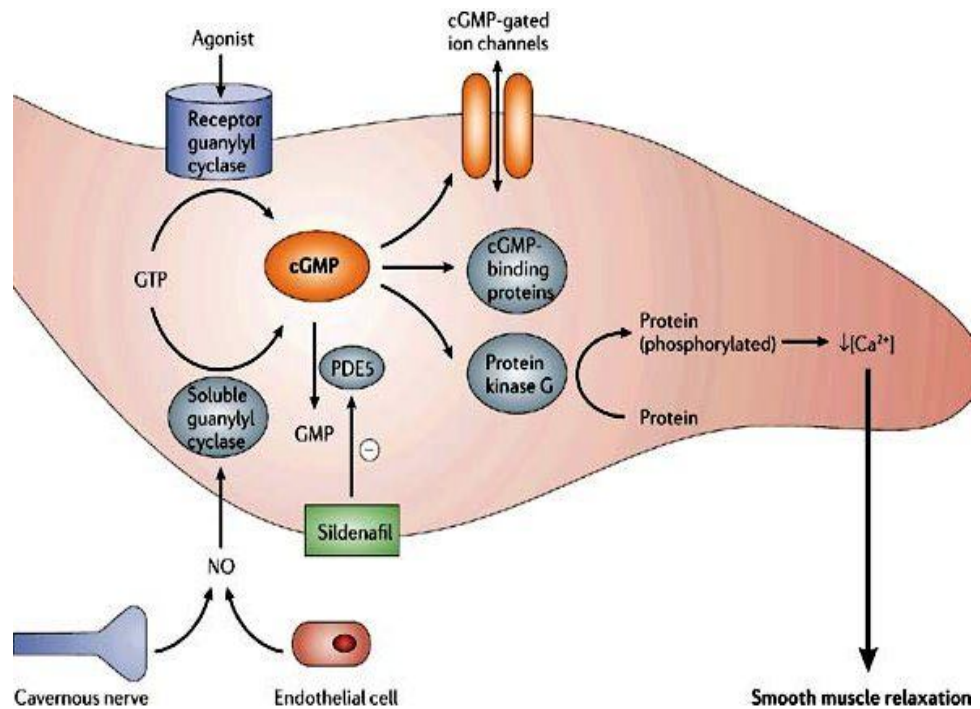

Figure 6.2: cGMP Pathway

### 6.5.3 Phospholipase C-Ca<sup>2+</sup> pathway

Another second messenger involved in intracellular signalling derives from the phospholipid phosphatidylinositol 4,5-bisphosphate (PIP<sub>2</sub>) present in the inner leaflet of the plasma membrane (Figure 6.3).

The hydrolysis of PIP<sub>2</sub> by the enzyme phospholipase C (PLC)- stimulated by a number of hormones and growth factors-produced two second messengers: diacylglycerol and inositol 1,4,5- trisphosphate (IP<sub>3</sub>).

These two messengers stimulate two downstream signalling pathway cascades: protein kinase C and Ca<sup>2+</sup> mobilization.

Two forms of PLC exist: PLC-β and PLC-γ. PLC-β is activated by G protein. PLC-γ contains SH2 domains that enable association with receptor protein tyrosine kinases. Tyrosine phosphorylation increases PLC-γ activity, which in turn stimulates the breakdown of PIP<sub>2</sub>. Diacylglycerol, derived from PIP<sub>2</sub> hydrolysis, activates members of the protein kinase C family (protein serine and threonine kinases).

Phorbol esters are tumor growth- promoting agents acting, like diacylglycerol, by stimulation of protein kinase C activities. Protein kinase C activates other intracellular targets such as protein kinases of the MAP

kinase pathway to produce the phosphorylation of transcription factors leading to changes in gene expression and cell proliferation.

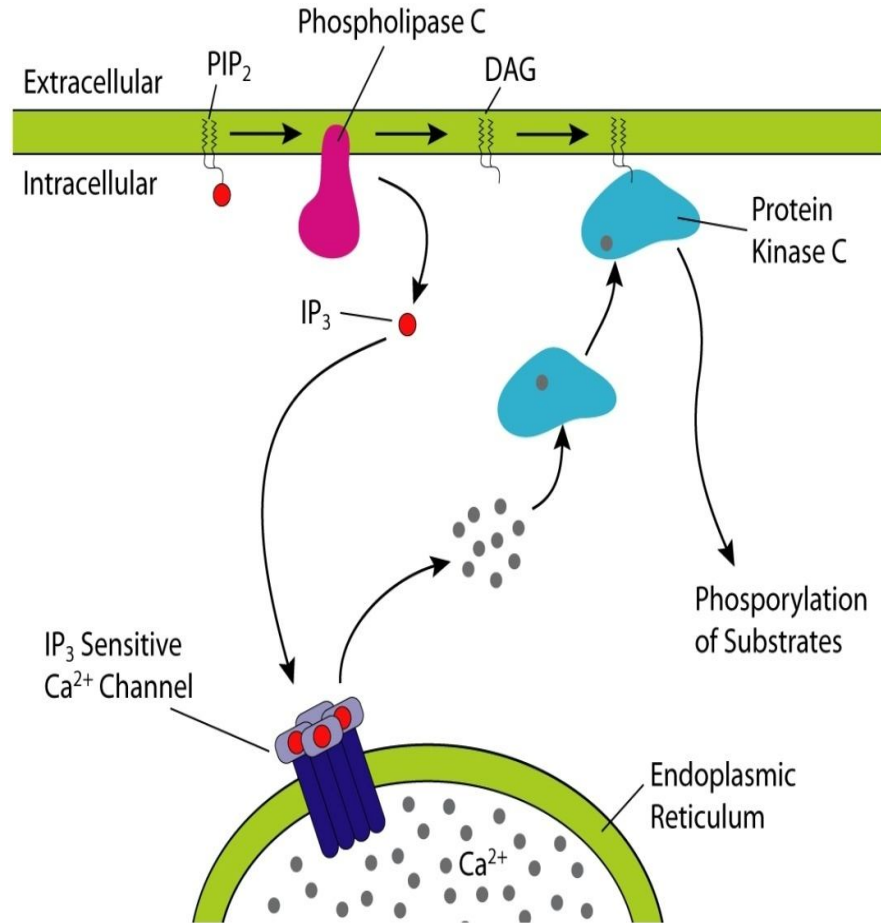

Figure 6.3: Phospholipase C-Ca<sup>2+</sup> pathway

#### 6.5.4 NF- $\kappa$ B transcription factor pathway

NF- $\kappa$ B is a transcription factor involved in immune responses in several cells and is stimulated by protein kinase C (Figure 6.4)

In its inactive state, the NF- $\kappa$ B and the complex is retained in the cytoplasm. The phosphorylation of I- $\kappa$ B—triggered by I- $\kappa$ B kinase—leads to the destruction of I- $\kappa$ B by the 26S proteasome and the release of NF- $\kappa$ B. The free NF- $\kappa$ B heterodimer translocates into the nucleus to activate gene transcription in response to immunologic and inflammatory signalling.



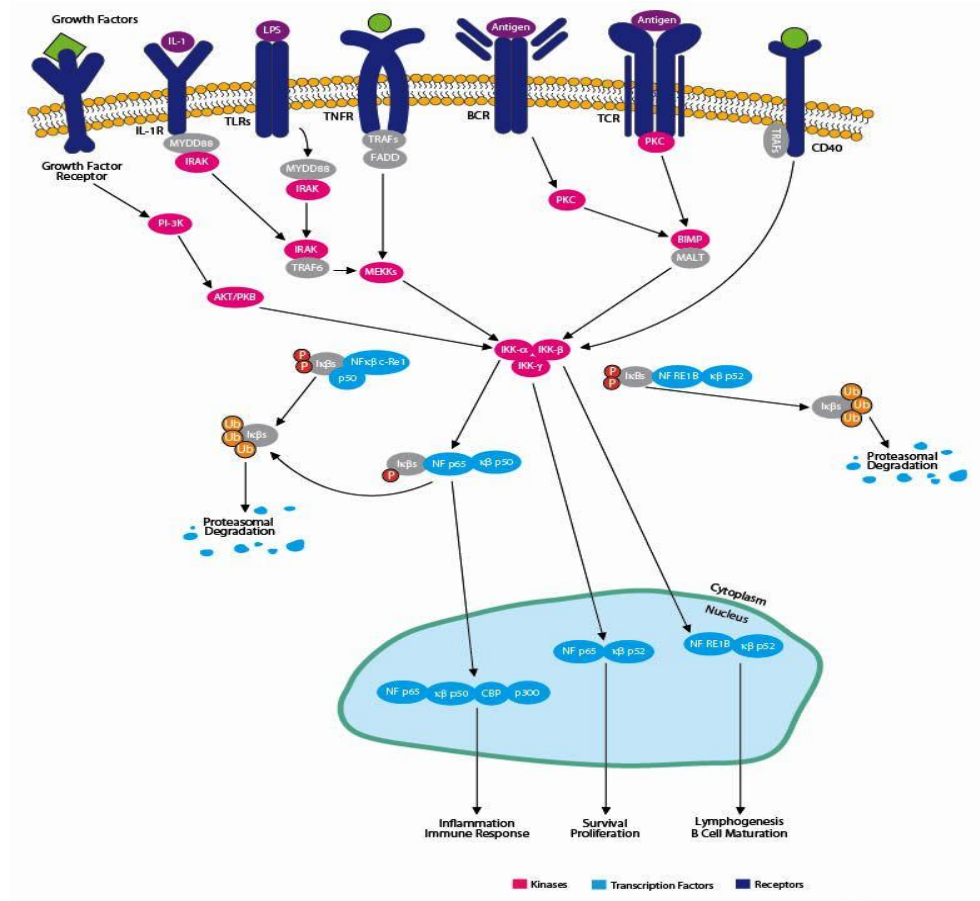

Figure 6.4: NF-κB Transcription factor pathway

### 6.5.5 Ca<sup>2+</sup>- calmodulin pathway

Although the second messenger diacylglycerol remains associated with the plasma membrane, the other second messenger IP<sub>3</sub>, derived from PIP<sub>2</sub>, is released into the cytosol to activate ion pumps and free Ca<sup>2+</sup> from intracellular storage sites. High cytosolic Ca<sup>2+</sup> concentrations (from a basal level of 0.1 μM to an increased 1.0 μM concentration after cytosolic release) activate several Ca<sup>2+</sup> dependent protein kinases and phosphatases. (Figure 6.5)

Calmodulin is a Ca<sup>2+</sup> - dependent protein that is activated when the Ca<sup>2+</sup> concentration increases to 0.5 μM. Ca<sup>2+</sup> - calmodulin complexes bind to a number of cytosolic target proteins to regulate cell responses. Note that Ca<sup>2+</sup> is an important second messenger and that its intracellular concentration can be increased not only by its release from intracellular storage sites but also by increasing the entry of Ca<sup>2+</sup> into the cell from the extracellular space.

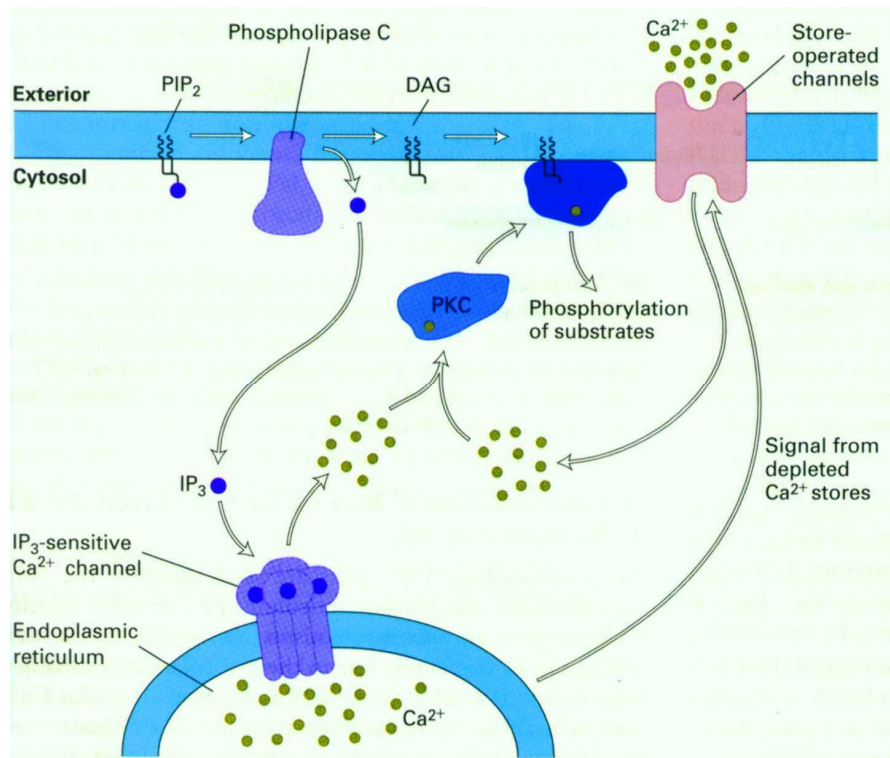

Figure 6.5: Ca<sup>2+</sup>- Calmodulin pathway

### 6.5.6 MAP kinase pathway

This pathway involves evolutionarily conserved protein kinases (yeast to humans) with roles in cell growth and differentiation. MAP kinases are protein serine and threonine kinases activated by growth factors and other signalling molecules (Figure 6.6).

A well- characterized form of MAP kinase is the ERK family. Members of the ERK (for extracellular signal- regulated kinase) family act through either protein tyrosine kinase or G protein—associated receptors. Both cAMP and Ca<sup>2+</sup> - dependent pathways can stimulate or inhibit the ERK pathway in different cell types.

The activation of ERK is mediated by two protein kinases: Raf, a protein serine or threonine kinase, which, in turn, activates a second kinase called MEK (for MAP kinase or ERK kinase). Stimulation of a growth factor receptor leads to the activation of the GTPbinding protein Ras (for rat sarcoma virus), which interacts with Raf. Raf phosphorylates and activates MEK, which then activates ERK by phosphorylation of serine and threonine residues. ERK then phosphorylates nuclear and cytosolic target proteins.

In the nucleus, activated ERK phosphorylates the transcription factors E1K-1 (for E-26-like protein I) and serum response factor (SRF). Which recognize the regulatory sequence called serum response element (SRE).

In addition to ERK, mammalian cells contain two other MAP Kinases called JNK and p38 MAP kinases. Cytokines and ultraviolet irradiation stimulate JNK and p38 MAP kinase activation mediated by small GTP-binding proteins different from Ras. These kinases are not activated by MEK but by a distinct dual kinase called MKK (for MAP kinase Kinase).

A key element in the ERK pathway are the Ras proteins, a group of oncogenic proteins of tumor viruses that cause sarcomas in rats. Mutations in the Ras gene have been linked to human cancer. Ras proteins are guanine nucleotide-binding protein with functional properties similar to the G protein A subunits (activated by GTP and inactivated by guanosine diphosphate[GDP]).

A difference with G protein is that Ras proteins do not associate with by subunits. Ras is activated by guanine nucleotide exchange factors to facilitate the release of GDP in exchange for GTP. The Activity of the Ras GTP complex is terminated by GTP hydrolysis, which is stimulated by GTPase-activating proteins.

In human cancers, mutation f Ras genes results in a breakdown failure of GTP and , therefore, the mutated Ras protein remains continuously in the active GRP-bound form.

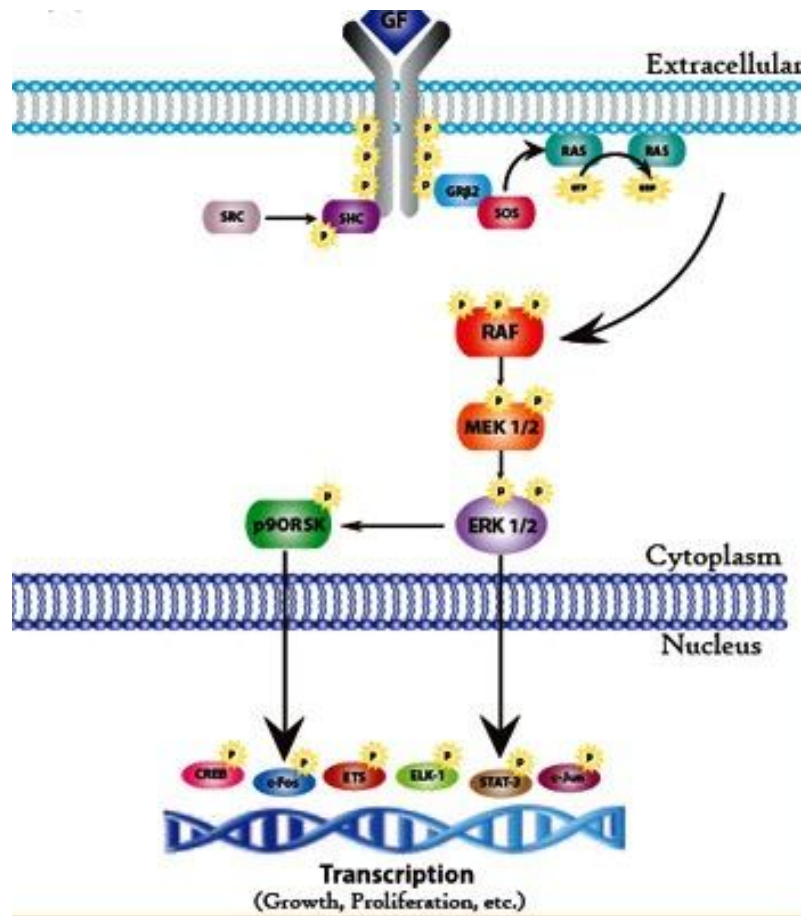

Figure 6.6: MAP Kinase pathway

### 6.5.7 JAK-STAT pathway

The preceding MAP kinase pathway links the cell surface to the nucleus signalling mediated by a protein kinase cascade leading to the phosphorylation of transcription factors.

The JAK-STAT pathway provides a close connection between protein tyrosine kinases and transcription factors by directly affecting transcription factors (Figure 6.7)

STAT (for signal transducers and activators of transcription) proteins are transcription factors with an SH2 domain and are present in the cytoplasm in an inactive state. Stimulation of a receptor by ligand binding recruits STAT proteins, which bind to the cytoplasmic portion of receptor-associated JAK protein tyrosine kinase through their SH2 domain and become phosphorylated. Phosphorylated STAT proteins then dimerize and translocate into the nucleus, where they activate the transcription of target genes.

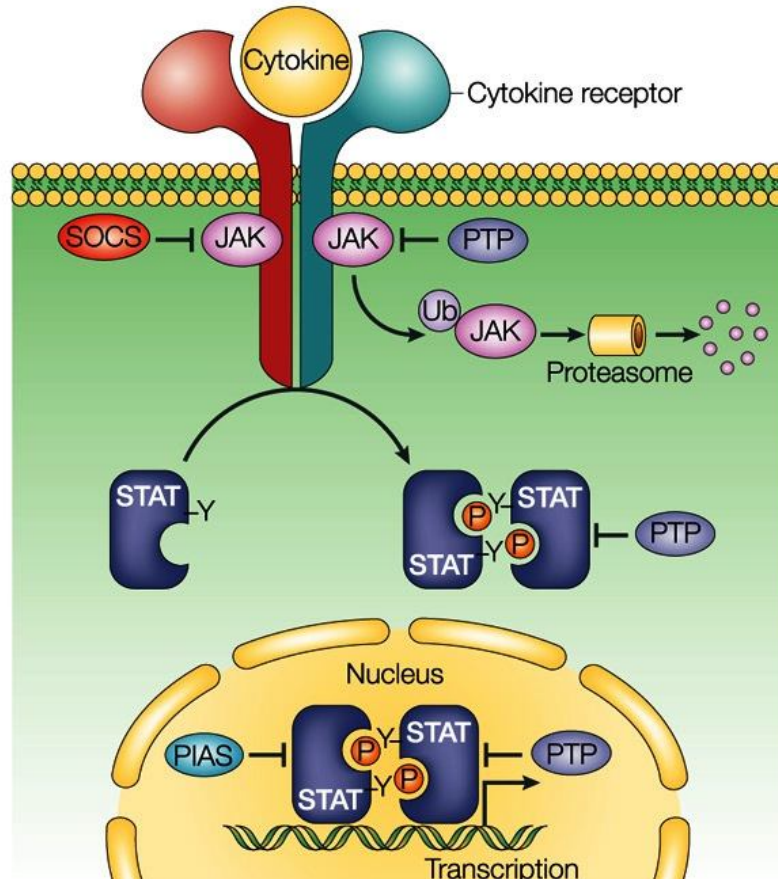

Figure 6.7: MAP Kinase pathway

## 6.6 Programmed Cell Death

The cells of a multi-cellular organism are members of a highly organized community. The number of cells in this community is tightly regulated—not simply by controlling the rate of cell division, but also by controlling the rate of cell death. If cells are no longer needed, they commit suicide by activating an intracellular death program. This process is therefore called programmed cell death, although it is more commonly called apoptosis (from a Greek word meaning “falling off,” as leaves from a tree).

In this section, we are going to learn what is apoptosis ?

Cells those die as a result of acute injury typically swell and burst. They spill their contents all over their neighbours—a process called *cell necrosis*—causing a potentially damaging inflammatory response. By contrast, a cell that undergoes apoptosis dies neatly, without damaging its neighbours. The cell shrinks and condenses. The cytoskeleton collapses, the nuclear envelope disassembles, and the nuclear DNA breaks up into fragments. Most

importantly, the cell surface is altered, displaying properties that cause the dying cell to be rapidly phagocytosed, either by a neighbouring cell or by a macrophage before any leakage of its contents occurs. This not only avoids the damaging consequences of cell necrosis but also allows the organic components of the dead cell to be recycled by the cell that ingests it.

The intracellular machinery responsible for apoptosis seems to be similar in all animal cells. This machinery depends on a family of proteases that have a cysteine at their active site and cleave their target proteins at specific aspartic acids. They are therefore called caspases. Caspases are synthesized in the cell as inactive precursors, or *procaspases*, which are usually activated by cleavage at aspartic acids by other caspases. Once activated, caspases cleave, and thereby activate, other procaspases, resulting in an amplifying proteolytic cascade. Some of the activated caspases then cleave other key proteins in the cell. Some cleave the nuclear lamins, for example, causing the irreversible breakdown of the nuclear lamina; another cleaves a protein that normally holds a DNA-degrading enzyme (a DNase) in an inactive form, freeing the DNase to cut up the DNA in the cell nucleus. In this way, the cell dismantles itself quickly and neatly, and its corpse is rapidly taken up and digested by another cell.

---

## 6.7 Summary

---

Cell signalling is a way of cell-cell communication. This is necessary for all functional regulations. Signal molecules and cell surface receptors facilitate this communication. Most of the hormones serves this purpose. For cell signalling important pathways are : cAMP pathway, cGMP pathway, Phospholipase C-Ca<sup>2+</sup> pathway, NF- $\kappa$ B transcription factor pathway, Ca<sup>2+</sup> -calmodulin pathway, MAP kinase pathway and JAK-STAT pathway.

In multicellular organisms, cells that are no longer needed or are a threat to the organism are destroyed by a tightly regulated cell suicide process known as programmed cell death, or apoptosis. Apoptosis is mediated by proteolytic enzymes called caspases, which trigger cell death by cleaving specific proteins in the cytoplasm and nucleus. Caspases exist in all cells as inactive precursors, or procaspases, which are usually activated by cleavage by other caspases, producing a proteolytic caspase cascade. The activation process is initiated by either extracellular or intracellular death signals, which cause intracellular adaptor molecules to aggregate and activate procaspases. Caspase activation is regulated by members of the Bcl-2 and IAP protein families.

---

## 6.8 Exercise

---

### Section A:

1. Name different types of cell signalling.
2. Write the name of sex steroids produced by gonads.
3. What is G-coupled receptors?
4. What are cytokinase receptors?
5. Name the major pathways of Intracellular Cell Signalling.
6. Define Apoptosis.

### Section B:

1. Explain JAK-SAT pathway.
2. Write a note on NF-kB factor pathway.
3. Enumerate Cell Surface Receptors and their mechanism of action.
4. Comment upon mechanism of action of cell signalling molecules.

### Section C:

1. Explain in detail calcium-calmodulin pathway.
2. Write an essay on cell surface receptors.

---

## 6.9 Glossary

---

- Signal Transduction
  - Receptors
  - Signal Molecules
  - Primary and Secondary messengers
  - Apoptosis
- 

## **6.10 Further readings**

---

- Freifelder D., Molecular Biology, Narosa Publishing House, New Delhi (1995)
- Alberts B., Bray D., Johnson A., Lewis J., Raff M., Roberts K. and Walter P., Essential of cell biology, Garland Publishing, Inc. New York (1997)
- Watson D.J, Baker T.A., Bell S.P., Gann A., Levine M. and Losick R,



## Unit- 7

---

# Signaling pathways in malignant transformation of cells, cell transformation, role of oncogenes, siRNA and miRNA basics, regulation of transcription and translation of proteins by miRNA

---

### Structure of the Unit

- 7.1 Objectives
- 7.2 Introduction
  - 7.2.1 Types of Cancer
  - 7.2.2 Causes of cancer
- 7.3 Oncogenes
  - 7.3.1 Proto-oncogenes
  - 7.3.2 Transformation of proto-oncogenes to oncogenes
  - 7.3.3 Retroviral oncogenes
- 7.4 Tumor suppressor genes
- 7.5 Signaling pathways in malignant transformation of cells
- 7.6 Cell transformation and cancer
- 7.7 miRNA
  - 7.7.1 Biogenesis of miRNA
- 7.8 siRNA
- 7.9 Regulation of transcription and translation of proteins by miRNA.
  - 7.9.1 mRNA degradation
  - 7.9.2 Translation Arrest
  - 7.9.3 Applications of RNAi

- 7.10 Summary
- 7.11 Glossary
- 7.12 Self-Learning Exercise
- 7.13 References

---

## 7.1 Objectives

---

After going through this unit you will be able to understand:

- Types and causes of cancer
- Genetic control of cancer: oncogenes and tumor suppressor genes
- Signaling pathways in malignant transformation of cells
- Cell Transformation
- mi and si RNA
- Regulation of transcription and translation of proteins by miRNA

---

## 7.2 Introduction

---

Cancer is a class of diseases characterized by out-of-control cell growth. The fundamental abnormality resulting in the development of cancer is the continual unregulated proliferation of cells. Rather than responding appropriately to the signals that control normal cell behavior cancer cells grow and divide in an uncontrolled manner, invading normal tissues and organs and eventually spreading throughout the body. The loss of growth control by cancer cells is a result of accumulation of abnormalities in the cell regulatory mechanisms. In almost all cases of cancer these losses occur due to genetic damage.

**Carcinogenesis/Oncogenesis/Tumorigenesis:** It is the process by which normal cells are transformed into cancer cells. It is characterized by a progression of changes at the cellular, genetic and epigenetic level that ultimately reprogram a cell to undergo uncontrolled cell division, thus forming a malignant mass.

### 7.2.1 Types of cancer

Cancer can result from abnormal proliferation of any of the different kinds of cell in the body, so there can be more than 100 types of cancers which can vary in their behavior and response to treatment. The most important issue in cancer pathology is the distinction between benign and malignant tumors. A tumor may be defined as any abnormal proliferation of cells, which may be benign or malignant. A benign tumor, such as a common skin wart remains confined to its

original location, neither invading normal tissues nor spreading to distant body sites. A malignant tumor, however, is capable of both invading, surrounding normal tissue and spreading throughout the body via the circulatory or lymphatic system (metastasis). Only malignant tumors are referred to as cancers, and it is their ability to invade and metastasize that makes them so dangerous.

Both benign and malignant tumors are classified according to the type of cells from which they arise:

Type of cancer	Originating cell type
Carcinomas	Epithelial cells
Sarcomas	Connective tissue (muscle, bone, cartilage)
Leukemias and Lymphomas	Blood forming cells and cells of the immune system respectively

### 7.2.2 Causes of cancer/ Carcinogen

A carcinogen is any substance or agent that is directly involved in causing cancer or increases the risk factor involved in carcinogenesis. This may be due to their ability to damage the genome or to disrupt cellular metabolic processes. Carcinogens increase the risk of cancer by altering cellular metabolism or damaging DNA directly in cells, which interferes with biological processes, and induces the uncontrolled, malignant division, ultimately leading to the formation of tumors. Carcinogens have been identified both by studies in experimental animals and by epidemiological analysis of cancer frequencies in human populations (e.g., the high incidence of lung cancer among cigarette smokers). Malignancy is a complex process involving many factors. The most common carcinogens include radiations (gamma radiations, alpha particles), cigarette smoke, alcohol, arsenic, dioxins. Although the general public perception is to associate cancer with synthetic compounds / xenobiotics, the natural agents can be equally responsible. There are many natural carcinogens. Aflatoxin B1, which is produced by the fungus *Aspergillus flavus* growing on stored grains, nuts and peanut butter, is an example of a potent, naturally occurring microbial carcinogen. Certain viruses such as hepatitis B and human papilloma virus have been found to cause cancer in humans.

Mutation in two broad classes of genes have been implicated in the onset of cancer: proto-oncogenes and tumor suppressor genes. Proto-oncogenes are activated to become oncogenes by mutations that cause the gene to be excessively active in growth promotion. Either increased gene expression or production of a hyperactive product will do it. Tumor suppressor genes normally restrain growth, so damage to them allows inappropriate growth. Many of the genes in both classes encode proteins that help regulate cell birth (i.e., entry into and progression through the cell cycle) or cell death by apoptosis; others encode proteins that participate in repairing damaged DNA.

---

## **7.3 Oncogenes**

---

Cancer results from alterations in critical regulatory genes that control cell proliferation, differentiation, and survival. Mutations in two broad classes of genes: proto-oncogenes (e.g., ras) and tumor-suppressor genes (e.g., Anaphase Promoting Complex; APC)—play key roles in cancer induction. These genes encode many kinds of proteins that help control cell growth and proliferation. Virtually all human tumors have inactivating mutations in genes that normally act at various cell-cycle checkpoints to stop a cell's progress through the cell cycle if a previous step has occurred incorrectly or if DNA has been damaged.

### **7.3.1 Proto-oncogene**

Proto-oncogene is a normal gene regulating cell growth and differentiation. Proto-oncogenes are involved in signal transduction and execution of mitogenic signals, usually through their protein products. Six types of proteins encoded by proto-oncogenes participate in control of cell growth:

Class I: Growth Factors

Class II: Receptors for Growth Factors and Hormones

Class III: Intracellular Signal Transducers

Class IV: Cell-Cycle Control Proteins

Class V: Proteins that affect apoptosis

Class V: Nuclear Transcription Factors

### **7.3.2 Transformation of proto-oncogenes to oncogenes**

A proto-oncogene converts to an oncogene due to mutation. Conversion, or activation, of a proto-oncogene into an oncogene generally involves a gain-of-function mutation. A gain of function mutation is a mutation that increases gene

expression enhancing activity of a protein, contrary, loss of function mutation result in reduced or abolished protein function.

Following mechanisms can produce oncogenes from the corresponding proto-oncogenes:

1. **Point mutation** (i.e., change in a single base pair) in a proto-oncogene that results in a constitutively active protein product.
2. **Chromosomal translocation** that fuses two genes together to produce a hybrid gene encoding a chimeric protein whose activity, unlike that of the parent proteins, often is constitutive (continuous expression of a gene).
3. **Chromosomal translocation** that brings a growth regulatory gene under the control of a different promoter that causes inappropriate expression of the gene.
4. **Amplification** (i.e., abnormal DNA replication) of a DNA segment including a proto-oncogene, so that numerous copies exist, leading to overproduction of the encoded protein.

An oncogene formed by either of the first two mechanisms encodes an “oncoprotein” that differs from the normal protein encoded by the corresponding proto-oncogene. In contrast, the other two mechanisms generate oncogenes whose protein products are identical with the normal proteins; their oncogenic effect is due to production at higher than normal levels or production in cells where they normally are not produced.

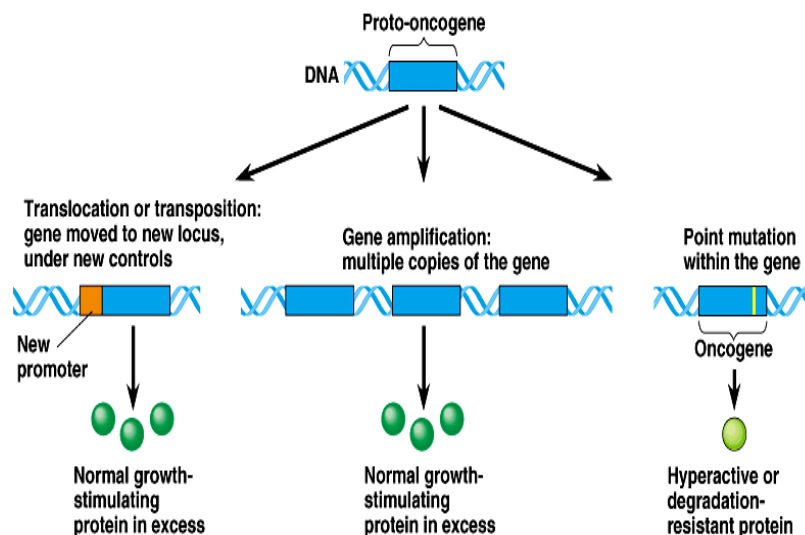

**Fig. 1. Mechanisms of transformation of proto-oncogene to oncogene**

### 7.3.3 Retroviral Oncogenes

Pioneering studies by Peyton Rous beginning in 1911 led to the initial recognition that a virus could cause cancer when injected into a suitable host animal. Many years later molecular biologists showed that Rous sarcoma virus (RSV) is a retrovirus whose RNA genome is reverse-transcribed into DNA, which is incorporated into the host-cell genome. RSV is one of the best studied retroviruses which infect chicken. RSV contains specific genetic information responsible for transformation of infected cell and this oncogene found in this retrovirus causes sarcoma and is therefore called src. Subsequent studies with mutant forms of RSV demonstrated that only the v-src gene, not the other viral genes, was required for cancer induction. The product of this gene is a protein kinase that phosphorylates tyrosine residues in other proteins. More than 40 different oncogenic retroviruses have been isolated from a variety of animals including chickens, turkeys, mice, rats, cats and monkeys.

---

## 7.4 Tumor Suppressor genes

---

Tumor-suppressor genes generally encode proteins that in one way or another inhibit cell proliferation. Five broad classes of proteins are generally recognized as being encoded by tumor-suppressor genes:

1. Intracellular proteins that regulate or inhibit progression through a specific stage of the cell cycle (e.g., p16 and Rb, retinoblastoma).
2. Receptors or signal transducers for secreted hormones or developmental signals that inhibit cell proliferation (e.g., TGF- $\beta$ , the hedgehog receptor patched).
3. Checkpoint-control proteins that arrest the cell cycle if DNA is damaged or chromosomes are abnormal (e.g., p53).
4. Proteins that promote apoptosis.
5. Enzymes that participate in DNA repair.

Although DNA-repair enzymes do not directly inhibit cell proliferation, cells that have lost the ability to repair errors, gaps, or broken ends in DNA accumulate mutations in many genes, including those that are critical in controlling cell growth and proliferation. Thus loss-of-function mutations in the genes encoding DNA-repair enzymes prevent cells from correcting mutations that inactivate tumor suppressor genes or activate oncogenes.

Generally one copy of a tumor-suppressor gene suffices to control cell proliferation, therefore, both alleles of a tumor suppressor gene must be lost or inactivated in order to promote tumor development. Thus, oncogenic loss-of-function mutations in tumor-suppressor genes are genetically recessive. In many cancers, tumor-suppressor genes have deletions or point mutations that prevent production of any protein or lead to production of a nonfunctional protein

Examples of tumor suppressor genes

**i) Rb (Retinoblastoma)**

Rb is a tumor suppressor gene. The Rb protein controls cell cycle moving past the G1 checkpoint. Rb protein binds to the regulatory transcription factor E2F. The factor E2F is required for synthesis of replication enzymes. Upon binding of Rb to E2F, no transcription/ replication can take place. Rb restricts the cell's ability to replicate DNA by preventing its progression from the G1 (first gap phase) to S (synthesis phase) phase of the cell division cycle. Rb is phosphorylated to pRb by certain Cyclin Dependent Kinases (CDKs). The phosphorylated/ mutated form of Rb (pRb) is unable to complex E2F and therefore, unable to restrict progression from the G1 phase to the S phase of the cell cycle. When E2F is free it activates factors like cyclins (e.g. Cyclin E and A), which push the cell through the cell cycle by activating cyclin-dependent kinases, this leads to cell division and progression of cancer.

**ii) p53**

Tumor protein p53, also known as p53, cellular tumor antigen p53, phosphoprotein p53 is a tumor suppressor gene. The name p53 is in reference to its apparent molecular mass: SDS-PAGE analysis indicates that it is a 53-kilodalton (kDa) protein. p53 has many mechanisms of anticancer function, and also plays a role in apoptosis, genomic stability, and inhibition of angiogenesis. p53 acts as a transcription factor for gene p21. It activates p21 which in turn binds to CDK I (cyclin dependent kinase 1). When p21 is complexed with CDK1 the cell cannot continue to the next stage of cell division. A mutant p53 can not bind DNA in an effective way, and, as a consequence, the p21 protein will not be available to act as the "stop signal" for cell division. This leads to uncontrolled cell proliferation and cancer. More than 50% cases of cancer involve mutation of p53 gene.

---

## 7.5 Signaling pathways in malignant transformation of cells

---

During normal development secreted signals such as Wnt (wingless), TGF- $\beta$  (Transforming growth factor- $\beta$ ), and Hedgehog (Hh) are frequently used to direct cells to particular developmental fates, which may include the property of rapid mitosis. The effects of such signals must be regulated so that growth is limited to the right time and place. Cellular signaling pathways are not isolated from each other but are interconnected to form complex signaling networks. Cells receive information from many different growth factor receptors and from cell-matrix and cell-cell contacts. They must then integrate this information to regulate diverse processes, such as protein synthesis and cell growth, motility, cell architecture and polarity, differentiation, and programmed cell death. The same signaling molecules are used to control different processes within different signaling complexes or at different intracellular locations. Moreover, signaling pathways are subject to developmental regulation and generate different outcomes in different cell types; the activation of a signaling molecule may have distinct consequences, depending on the cellular context. Understanding how these extraordinarily complex signaling networks function in vivo and how they are altered in cancer cells represents a major intellectual challenge.

The ability of intracellular signaling networks to integrate and distribute regulatory information requires that individual signaling proteins must act as nodes, responding to multiple inputs and regulating multiple effector outputs. One of the major advances in the last decade has been the recognition that many signaling proteins contain modular protein domains that mediate protein-protein interactions. These interaction modules serve to target signaling proteins to their substrates or to specific intracellular locations, to respond to posttranslational modifications, such as phosphorylation, acetylation and methylation, and to link polypeptides into multi-protein signaling complexes and pathways.

The intricacy of cellular signaling networks has major implications for our understanding of tumor cell behavior and for our ability to use this knowledge for cancer therapy. Cell proliferation, motility, and survival are regulated by multiple pathways, and the changes that occur in cancer cells are the result of multiple alterations in cellular signaling machinery.



The following section gives an account of the most prominent signaling pathways involved in malignant transformation of cells.

### **1) Mitogen-activated protein kinases/extracellular signal-regulated kinases (MAP/ ERK) pathway**

The MAPK/ERK pathway (also known as the Ras-Raf-MEK-ERK pathway) is a chain of proteins in the cell that communicates a signal from a receptor on the surface of the cell to the DNA in the nucleus of the cell. The signal starts when a signaling molecule binds to the receptor on the cell surface and ends when the DNA in the nucleus expresses a protein and produces some change in the cell, such as cell division. The pathway includes many proteins, including MAPK (mitogen-activated protein kinases, originally called ERK, extracellular signal-regulated kinases), which communicate by adding phosphate groups to a neighboring protein, which acts as an "on" or "off" switch. Aberrant activation of the pathway is frequently seen in human cancers. The RAF–MAPK/(MEK)–ERK signaling cascade has been the most extensively studied, its role in a variety of human cancers is well established particularly those associated with activation of RAS protein (ras is an oncogene) which binds to and activates the RAF kinase, triggering engagement of this pathway. Upon RAS activation, RAF is recruited to the cell membrane where subsequent changes in RAF phosphorylation status result in stimulation of its serine-threonine kinase activity. Activated RAF triggers sequential phosphorylation and activation of the MEK1/MEK2 dual-specificity protein kinases and ERK, which translocates to the nucleus where they regulate the activity of several transcription factors that induce the expression of multiple genes required for survival and proliferation. Mutation in any protein of this signaling pathway leads to development of many cancers.

### **2) Epidermal growth factor receptor (EGFR) and Human Epidermal Growth Factor (HER2/ErbB-2) pathway**

The epidermal growth factor receptor (EGFR; ErbB-1; HER1 in humans) is the cell-surface receptor for members of the epidermal growth factor family (EGF-family) of extracellular protein ligands. Growth factor peptides and their receptors are involved in cell proliferation, differentiation and survival and are often overexpressed in human cancer cells. The EGFR is a 170-kDa transmembrane protein able to bind several ligands, such as endothelial growth factor (EGF), transforming growth factor- $\alpha$  (TGF- $\alpha$ ), heparin-binding EGF, amphiregulin, betacellulin, epiregulin and neuregulin G2b. Ligand binding is

followed by receptor dimerization and Tyrosine Kinase (TK) auto-activation which in turn, triggers a cascade of intracellular signaling pathways. Activation of EGFR or HER2 signaling triggers multiple and integrated biological responses, including mitogenesis, apoptosis, cellular motility, angiogenesis and regulation of differentiation. Deregulation of these tightly regulated ErbB receptor signaling pathways contributes to malignant transformation.

Several mechanisms lead to aberrant receptor activation, including receptor overexpression, gene amplification, activating mutations, overexpression of receptor ligands, and/or loss of negative regulatory mechanisms.

One of the most studied growth factor receptor systems is the HER (also defined ErbB) family. Amplification or overexpression of this oncogene has been shown to play an important role in the development and progression of certain aggressive types of breast cancer. In recent years the protein has become an important biomarker and target of therapy for approx. 30% of breast cancer patients.

### **3) Ras**

The signal transduction cascade activated by growth factor receptors, cytokines (Interleukin 2, 3), and hormones (insulin, Insulin-like growth factor-IGF), involves the 21-kDa guanine-nucleotide-binding proteins encoded by the ras proto-oncogene. Ras (abbreviated form of Rat sarcoma) is the name given to a family of related proteins which are ubiquitously expressed in all cell lineages and organs. All Ras protein family members belong to a class of protein called small GTPase, and are involved in transmitting signals within cells. The aberrant activation of Ras proteins is implicated in facilitating virtually all aspects of the malignant phenotype, including cellular proliferation, transformation, invasion and metastasis. Ras activity is regulated by cycling between inactive GDP-bound and active GTP-bound forms. Once in its GTP-bound form, RAS activates several effector pathways that mediate cell proliferation and suppression of apoptosis. Hydrolysis of GTP by Ras is facilitated by GTPase-activating proteins (GAPs) such as p120GAP and NF1. Point mutations in the ras gene (at residues 12, 13 or 61) are oncogenic because they render Ras insensitive to GAP stimulation, resulting in a permanently active GTP-bound Ras form, which continuously activates the downstream pathways in the absence of any upstream stimulation resulting in unchecked cell proliferation leading to development of cancer. Mutation of the ras gene is

involved in many tumor types, including roughly half of all colon cancers and 90% of pancreatic carcinomas (Goodsell, 1999).

#### 4) Protein Kinase C (PKC)

PKC belongs to a class of serine–threonine kinases composed of 12 closely related isozymes that have distinct and, in some cases, opposing roles in cell growth and differentiation. Based on their structural and activation characteristics, this protein family can be further classified into three subfamilies: conventional or classic PKC isozymes (cPKCs:  $\alpha$ ,  $\beta$  and  $\gamma$ ), novel (nPKCs:  $\delta$ ,  $\epsilon$ ,  $\eta$  and  $\theta$ ) and atypical (aPKCs:  $\zeta$ ,  $\iota$  and  $\lambda$ ). Activation of classical enzymes (cPKC) depends on  $\text{Ca}^{+2}$  and diacylglycerol (DAG), novel enzymes (nPKC) are activated by diacylglycerol (DAG), and atypical enzyme (aPKC) activation takes place independently of calcium or DAG, but they may be activated by other PKC.

PKC isozymes are involved in multiple signal transduction systems that respond to a variety of external stimulators, including hormones, growth factors, and other membrane receptor ligands. In general, PKCs are involved in various physiological processes of cells. Short-term activation of PKC is often associated with short-term events such as secretion and ion-influx. In contrast, sustained activation is suggested to induce long-term effects such as proliferation, differentiation, apoptosis, migration, or tumorigenesis. PKC isoenzymes have been shown to display variable expression profiles during cancer progression depending on a particular cancer type. The most common isoenzymes displaying alterations in expression during cancer progression are  $\alpha$ ,  $\beta$ , and  $\delta$ , but abnormal expression of other isoenzymes may also take place.

#### 5) Protein kinase B (PKB)/Akt

Protein kinase B (PKB), also known as Akt, is a serine/threonine-specific protein kinase that plays a key role in multiple cellular processes such as glucose metabolism, apoptosis, cell proliferation, transcription and cell migration. It is an important pathway that regulates the signaling of multiple essential biological processes. Akt is an indirect positive regulator of the mammalian target of rapamycin (mTOR), a central controller of eukaryotic cell growth and proliferation, through the phosphorylation and inactivation of mTOR inhibitors, such as tuberin (TSC2). The activation of Akt provides cells with a survival signal that allows them to withstand apoptotic stimuli, through phosphorylation/inactivation of pro-apoptotic proteins, such as BAD and Caspase 9, and transcriptional factors. Moreover, Akt is involved in the

regulation of cell metabolism through inhibition of glycogen synthase kinase 3 (GSK3). AKT and its regulators play an important role in cancer pathogenesis: Akt is overexpressed in a variety of human cancer types and it confers chemoresistance.

### **6) Transforming growth factor beta (TGF- $\beta$ )**

Transforming growth factor-beta (TGF- $\beta$ ) is a multifunctional regulatory polypeptide that is the member of a large family of cytokines that controls many aspects of cellular function, including cellular proliferation, differentiation, migration, apoptosis, adhesion, angiogenesis, immune surveillance, and survival. The actions of TGF- $\beta$  are dependent on several factors including cell type, growth conditions, and the presence of other polypeptide growth factors. One of the biological effects of TGF- $\beta$  is the inhibition of proliferation of most normal epithelial cells using an autocrine mechanism of action, and this suggests a tumor suppressor role for TGF- $\beta$ . Loss of autocrine TGF- $\beta$  activity and/or responsiveness to exogenous TGF- $\beta$  provide epithelial cells with a growth advantage leading to malignant progression. This suggests a pro-oncogenic role for TGF-beta in addition to its tumor suppressor role.

In normal cells, TGF- $\beta$ , acting through its signaling pathway, stops the cell cycle at the G1 stage to stop proliferation, induce differentiation, or promote apoptosis. When a cell is transformed into a cancer cell, parts of the TGF- $\beta$  signaling pathway are mutated, and TGF- $\beta$  no longer controls the cell. These cancer cells proliferate. The surrounding stromal cells (fibroblasts) also proliferate. Both cells increase their production of TGF- $\beta$ . This TGF- $\beta$  acts on the surrounding stromal cells, immune cells, endothelial and smooth-muscle cells. It causes immunosuppression and angiogenesis, which makes the cancer more invasive. TGF- $\beta$  also converts effector T-cells, which normally attack cancer with an inflammatory (immune) reaction, into regulatory (suppressor) T-cells, which turn off the inflammatory reaction.

---

## **7.6 Cell transformation and cancer**

---

The morphology and growth properties of tumor cells clearly differ from those of their normal counterparts; some of these differences are also evident when cells are cultured. The study of tumor induction by radiation, chemicals or viruses requires experimental systems in which the effects of a carcinogenic

agent can be observed. Although the activity of carcinogens can be assayed in intact animals, such experiments are difficult to quantitate and control. The development of in vitro assays to detect the conversion of normal cells to tumor cells in culture is called cell transformation; it is a major advance in cancer research. Such assays are designed to detect transformed cells, displaying the in vitro growth properties of tumor cells, following exposure of normal cells to a carcinogenic agent. The conversion of normal cells into tumor cells involves changes in the activity of number of distinct genes and proteins in the cell.

The first and most widely used assay of cell transformation is the “Focus assay”, developed by Howard Temin and Harry Rubin in 1958. This assay is based on the ability to recognize a group of transformed cells as a morphologically distinct “focus” against a background of cells on the surface of a culture dish. The focus assay takes advantage of three properties of transformed cells: altered morphology, loss of contact inhibition, and loss of density-dependent inhibition of growth. The result is the formation of a colony of morphologically altered transformed cells that overgrow the background of normal cells in the culture. Such foci of transformed cells can usually be detected and quantified within a week or two after exposure to a carcinogenic agent. In general, cells transformed in vitro are able to form tumors following inoculation into susceptible animals, supporting in vitro transformation as a valid indicator of the formation of cancer cells.

---

## **7.7 mi RNA**

---

In addition to messenger RNA (mRNA), ribosomal RNA (rRNA) and transfer RNA (tRNA), which play central roles within cells, there are a number of regulatory, non-coding RNAs (ncRNAs). These non-coding RNAs are of variable length and have no long open reading frame. They do not code proteins, but they may act as riboregulators, and their main function is posttranscriptional regulation of gene expression. Many ncRNAs have been identified and characterized both in prokaryotes and eukaryotes, and are involved in the specific recognition of cellular nucleic acid targets through complementary base pairing, controlling cell growth and differentiation. The mechanism of gene regulation by RNAs is called RNA interference (RNAi). Two types of small ribonucleic acid (RNA) molecules – microRNA (miRNA) and small interfering RNA (siRNA) are central to RNA interference. These small RNAs can bind to other specific mRNA molecules and either increase or decrease their activity, for example by preventing an mRNA from producing a

protein. RNA interference has an important role in defending cells against parasitic nucleotide sequences – viruses and transposons. It also influences development.

RNA interference (RNAi) is manifested in several ways: by inhibiting translation of mRNA, through destruction of mRNA, or by transcriptional silencing of the promoter that directs expression of that mRNA. The roles of these RNAs range from developmental control in the worm *Caenorhabditiselegans* and the plant *Arabidopsis* to mechanisms that protect organisms against viral infections.

### 7.7.1 Biogenesis of miRNA

miRNA is a small non-coding RNA molecule found in plants, animals, and some viruses, which functions in RNA silencing and post-transcriptional regulation of gene expression. It is typically 21-22 nucleotides long. microRNA genes are predominately located in intergenic regions. However, they have also been identified in introns and exons of protein-coding genes.

miRNA genes are transcribed by RNA Polymerase II. The polymerase binds to a promoter near the DNA sequence encoding the hairpin loop of the primary RNA (pri-miRNA). The resulting transcript undergoes post-transcriptional modification: capping and polyadenylation and splicing.

The short RNAs are generated by two RNA cleavage reactions from this long RNA transcript, pri-miRNA which has a hairpin-shaped secondary structure. The first cleavage liberates the stem loop, called the pre-miRNA; the second generates the mature miRNA from the pre-miRNA. The two cleavage reactions required to generate the miRNA from these primary transcript are mediated by two distinct RNases. One is Dicer and the other is Drosha.

Two-step nucleolytic processing to generate an active mi RNA:

Two specialized RNA cleaving enzymes are required to process the initial pri-miRNA transcript, containing the stem loop structure, into the mature miRNA. The first enzyme is Drosha, a member of RNase III family of enzymes. Drosha makes two cleavages that cut the stem loop region of the RNA (pre-miRNA) out of the primary transcript RNA (pri-miRNA). This enzyme works together with an essential subunit protein (called Pasha in some organisms and DGCR8 in others), and together these two proteins form an active **microprocessor complex**. The pre-miRNA generated by Drosha is approximately 65-70 nucleotides long. Drosha resides in the nucleus and so this cleavage step takes place in the nucleus.

The base-paired stem in the pri-miRNA is about 33bp long, the loop at the top of this stem is of variable size. The stem region is divided into two functional segments: lower stem (11 bp long) and upper stem (22 bp long). Drosha cleaves 11 bp away from the dsRNA-ssRNA junction, that is, between the lower and upper stems in the pri-miRNA.

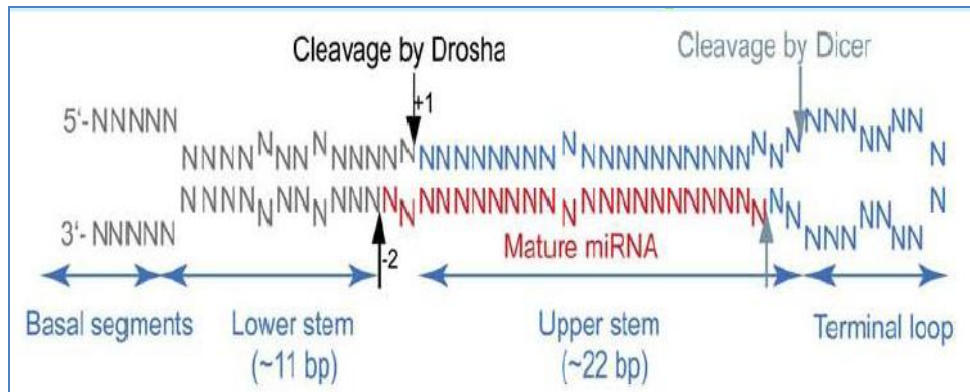

**Fig. Structure of pri-miRNA showing Drosha and Dicer cleavage sites.**

The pre-miRNA liberated by Drosha is exported to the cytoplasm where the second RNA cleavage reaction takes place. Pre-miRNA hairpins are exported out of the nucleus in a process involving the nucleocytoplasmic shuttler Exportin-5. This protein, a member of the karyopherin family, recognizes a two-nucleotide overhang left by the RNase III enzyme Drosha at the 3' end of the pre-miRNA hairpin. Exportin-5-mediated transport to the cytoplasm is energy-dependent, using GTP bound to the Ran protein. In the cytoplasm, the pre-miRNA hairpin is cleaved by the RNase III enzyme Dicer. This endoribonuclease interacts with the 3' end of the hairpin and cuts away the loop joining the 3' and 5' arms, yielding an imperfect miRNA:miRNA duplex about 22 nucleotides in length. The action of Drosha and Dicer generates a 21-25 nucleotide RNA molecule that guides regulation of gene expression. The regulatory RNAs regulate gene expression by forming the RNA-induced silencing complex (RISC). The miRNA is denatured to give a "guide RNA" (active form of miRNA), a component of RISC and a passenger RNA, which usually gets discarded. RISC is a multicomponent complex which includes the guide RNA, and a protein called Argonaute, which is the RNA cleaving enzyme. Argonaute is often called "Slicer" and mRNA cleavage is called "slicing".

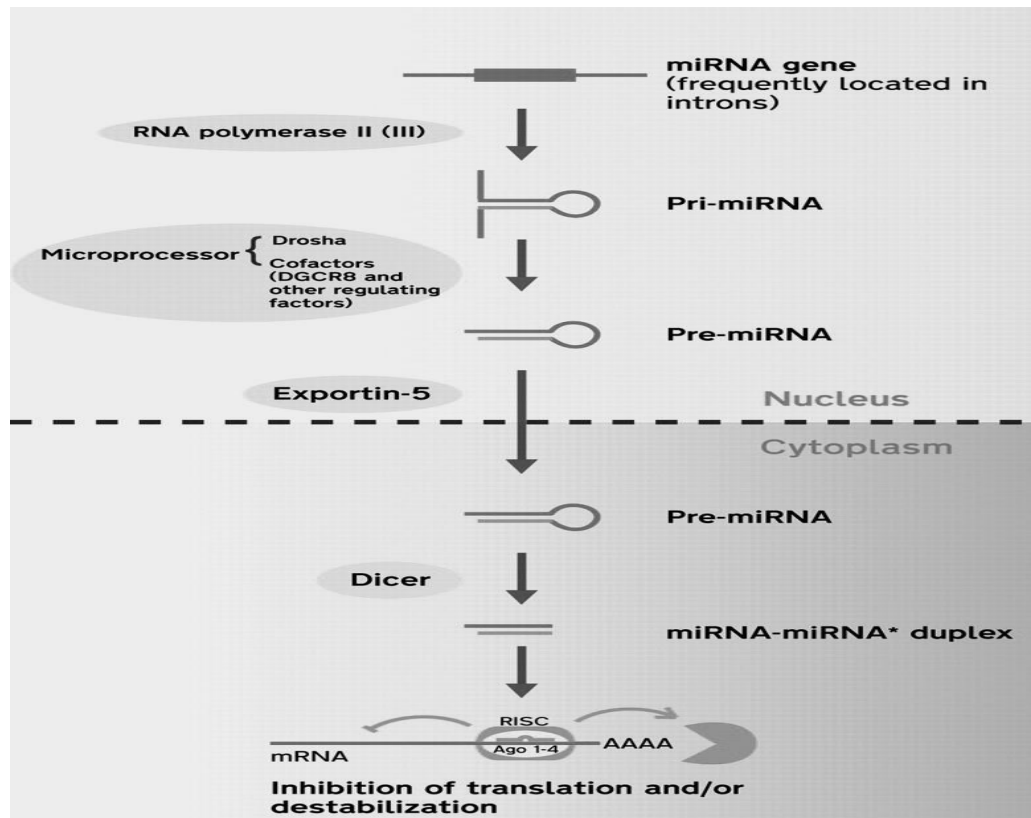

**Fig. Biogenesis of miRNA and mechanism of gene control**

## 7.8 Small interfering RNAs (siRNA)

Small interfering RNA (siRNA), sometimes known as short interfering RNA or silencing RNA, is a class of double-stranded RNA molecules, 20-25 base pairs in length. siRNA plays many roles, most notable being RNA interference (RNAi) pathway, where it interferes with the expression of specific genes with complementary nucleotide sequences. siRNA functions by breaking down the mRNA after transcription resulting in no translation. siRNAs have a well-defined structure: a short (usually 20 to 24 bp) double-stranded RNA (dsRNA) with phosphorylated 5' ends and hydroxylated 3' ends with two overhanging nucleotides. The Dicer enzyme catalyzes production of siRNAs from long dsRNAs and small hairpin RNAs.

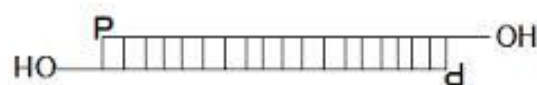

Schematic representation of a siRNA molecule: a ~19-21 base pair RNA core duplex that is followed by a 2 nucleotide 3' overhang on each strand. OH: 3' hydroxyl, P: 5' phosphate.



---

## 7.9 Regulation of transcription and translation of proteins by miRNA

---

RNA interference (RNAi) is a biological process in which RNA molecules inhibit gene expression, typically by causing the destruction of specific mRNA molecules. Historically, it was known by other names, including co-suppression, post transcriptional gene silencing (PTGS), and quelling. Andrew Fire and Craig C. Mello shared the 2006 Nobel Prize in Physiology or Medicine for their work on RNA interference in the nematode worm *Caenorhabditiselegans*, which they published in 1998.

miRNAs (microRNAs) are short non-coding RNAs that regulate gene expression post-transcriptionally. They generally bind to the 3'-UTR (untranslated region) of their target mRNAs and repress protein production by destabilizing the mRNA and translational silencing. Following biogenesis of the miRNA and formation of RISC, the RISC complex is directed towards the mRNA to be degraded. The miRNA loaded in the complex targets the RISC to specific binding sites in the 3' untranslated region (UTR) of mRNA transcripts by base-pairing interaction across the seed sequence, the 7- to 8-nt sequence of the mature miRNA that dictates miRNA:mRNA binding. The RISC is a ribonucleoprotein complex required for miRNA:mRNA interaction and miRNA-mediated gene silencing. Multiple proteins have been identified as components of the RISC including argonaute protein (AGO1 through AGO4) and Dicer. The argonaute protein has a major role in the RISC, functioning as the catalytic component of endonucleolytic cleavage. Dicer, functions as a ribonuclease in miRNA biogenesis leading to release of the mature miRNA duplex.

The regulatory RNAs regulate gene expression by following two mechanisms:

1. Degradation of mRNA
2. Translation Arrest

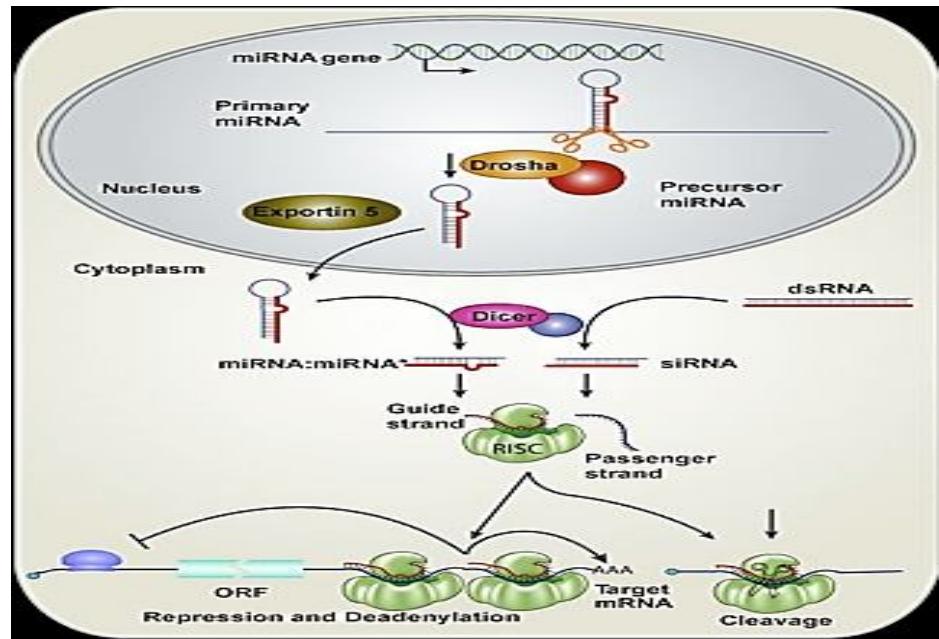

### 7.9.1 Degradation of mRNA

Regulation of translation via degradation of the mRNA sequence by small RNA has been well characterized. The RISC with a bound siRNA recognizes complementary messenger RNA (mRNA) molecules and degrades them, resulting in substantially decreased levels of protein translation and effectively turning off the gene. Unlike miRNA, which are produced from genome-encoded precursors as discussed previously, siRNA are short RNA sequences (~21 nt) produced from long double-stranded RNA precursors. The siRNA has sequences homologous to the mRNA to be degraded. This shared homology across the complete siRNA:mRNA sequence results in post-transcriptional regulation of gene expression through endonucleolytic cleavage of the target mRNA sequence at the binding site by utilizing components of the miRNA machinery, including Dicer.

The active components of an RNA-induced silencing complex (RISC) are endonucleases called argonaute proteins, which cleave the target mRNA strand complementary to their bound siRNA. As the fragments produced by dicer are double-stranded, they could each in theory produce a functional siRNA. However, only one of the two strands, which is known as the guide strand, binds the argonaute protein and directs gene silencing. The other anti-guide strand or passenger strand is degraded during RISC activation. The separation of strands is ATP-independent and performed directly by the protein components of RISC.

## 7.9.2 Translation Arrest

The miRNA controls translation by multiple mechanisms:

- (i) **Deadenylation:** Repression of translation via miRNA is a result of deadenylation of the poly-A tail and subsequent decapping of the mRNA sequence. As a result, the mRNA sequence becomes unstable and is susceptible to degradation, resulting in decreased mRNA abundance and subsequent decrease translation. Evidences suggest that miRNA.

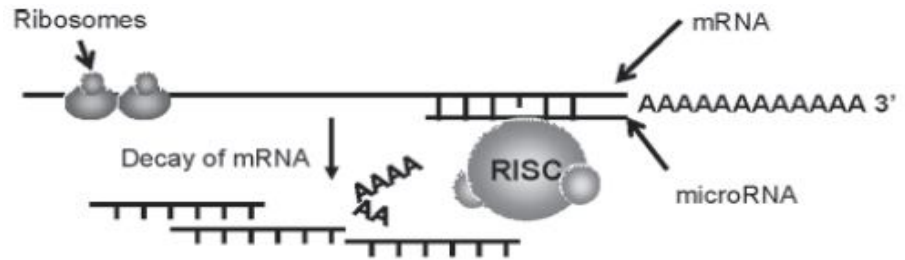

- (ii) **Blocking of initiation:** Similar to the previously discussed mechanism, the miRNA binds to the RISC and targets the 3' UTR of the mRNA sequence. However, instead of inducing degradation of the mRNA by deadenylation, targeting the miRNA:RISC complex to the 3' UTR is thought to activate a sequence of events that block initiation proteins from binding to the 5' cap of the mRNA.

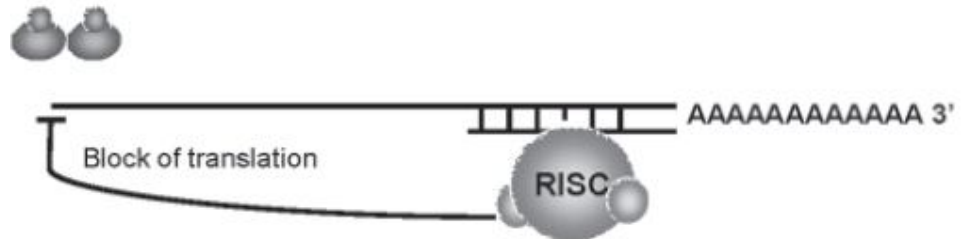

- (iii) **Translocation to Processing Bodies:** A third proposed mechanism of miRNA action involves posttranscriptional regulation by translocation of the miRNA:mRNA complex to cytoplasmic foci in the cell, known as processing bodies (P-bodies), after the miRNA:RISC complex binds the mRNA target. P-bodies do not contain ribosomal proteins for translation but possess enzymes and

factors for mRNA turnover and repression of translation.

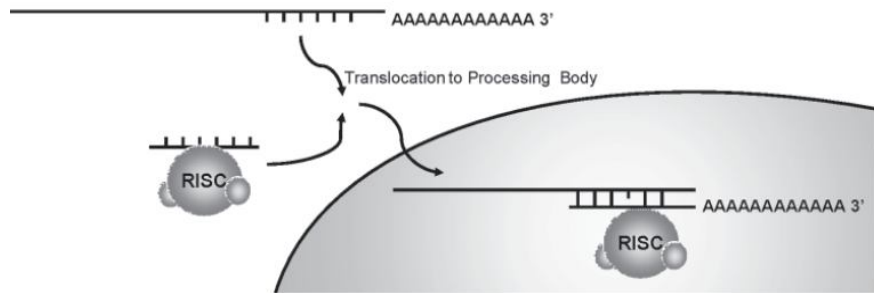

### 7.9.3 Applications of RNAi

- **Gene Knockdown:** The RNA interference pathway is often exploited in experimental biology to study the function of genes in cell culture and in vivo in model organisms. Double-stranded RNA is synthesized with a sequence complementary to a gene of interest and introduced into a cell or organism, where it is recognized as exogenous genetic material and activates the RNAi pathway. Using this mechanism, researchers can cause a drastic decrease in the expression of a targeted geneRNA. Studying the effects of this decrease can show the physiological role of the gene product.
- **Functional Genomics:** Functional genomics using RNAi is a particularly for genomic mapping.
- **Medical:** Potential antiviral therapies include topical microbicide treatments that use RNAi to treat infection. RNA interference is also a promising way to treat cancers by silencing genes differentially upregulated in tumor cells or genes involved in cell division.
- **Biotechnological Applications:** RNA interference has been used for applications in biotechnology like food, insecticides, transgenic plants etc.

---

## 7.10 Summary

---

Cancer is a class of diseases characterized by out-of-control cell growth. The fundamental abnormality resulting in the development of cancer is the continual unregulated proliferation of cells. The process by which normal cells are transformed into cancer cells is called carcinogenesis. A tumor may be defined as any abnormal proliferation of cells, which may be benign or malignant. A benign tumor,remains confined to its original location. A malignant tumor,

however, is capable of both invading, surrounding normal tissue and spreading throughout the body via the circulatory or lymphatic system. A carcinogen is any substance or agent that is directly involved in causing cancer or increases the risk factor involved in carcinogenesis. Cancer results from alterations in critical regulatory genes that control cell proliferation, differentiation, and survival- the proto-oncogenes and tumor suppressor genes.

Cellular signaling networks has major implications in the malignant transformation of cells. The MAPK, HER, Ras, TGF- $\beta$ , PKC are the major signaling pathways involved in malignant transformation.

miRNA and siRNA are regulatory, non-coding RNAs (ncRNAs) which act as riboregulators, and their main function is posttranscriptional regulation of gene expression. The mechanism of gene regulation by RNAs is called RNA interference (RNAi). These regulatory RNAs regulate gene expression by either degrading the mRNA or inhibiting translation.

---

## 7.11 Glossary

---

- **Metastasis:** The movement or spreading of cancer cells from one organ or tissue to another.
- **Carcinogenesis:** The process of tumor formation.
- **Apoptosis:** It is the process of programmed cell death (PCD) that occur in multicellular organisms. Biochemical events lead to characteristic cell changes (morphology) and death. These changes include blebbing, cell shrinkage, nuclear fragmentation, chromatin condensation, and chromosomal DNA fragmentation.
- **Cell surface receptors:** Cell surface receptors (membrane receptors, transmembrane receptors) are specialized integral membrane proteins that take part in communication between the cell and the outside world.
- **Constitutive expression/ gene:** A gene that is transcribed continually.
- **Promoter:** Promoter is a region of DNA that initiates transcription of a particular gene. Promoters are located near the transcription start sites of genes, on the same strand and upstream.
- **Angiogenesis:** Angiogenesis is the physiological process through which new blood vessels form from pre-existing vessels. It is a normal

and vital process in growth and development, it is also a fundamental step in the transition of tumors from a benign state to a malignant one.

- **Xenobiotics:** A xenobiotic is a foreign chemical substance found within an organism that is not normally naturally produced by or expected to be present within that organism.

---

## 7.12 Self-Learning Exercise

---

### Section -A (Very Short Answer Type)

1. Define oncogenes.
2. Write names of two tumor suppressor genes.
3. What are regulatory RNAs.
4. Write names of the proteins involved in miRNA biogenesis.
5. What is RISC.

### Section -B (Short Answer Type)

1. What are the different types of cancers based on the type of originating cell?
2. What are tumor suppressor genes?
3. Differentiate between benign and malignant tumor.
4. What is metastasis?
5. What is RNA interference?
6. What do you mean by cell transformation?

### Section -C (Long Answer Type)

1. Give a detailed account of oncogenes.
2. Describe the various signaling pathways involved in cellular transformation of malignant cell.
3. Give an account of regulation of transcription and translation of proteins by miRNA.
4. Explain the biogenesis of miRNA with suitable diagrams.

---

## 7.13 References

---

- Bianco R, Melisi D, Ciardiello F, Tortora G. Key cancer cell signal transduction pathways as therapeutic targets. *European Journal Of Cancer* 42 (2006). 290-294.
- Goodsell DS. The Molecular Perspective: The ras Oncogene. *The Oncologist* 1999;4:263-264.
- Martin GS. Cell signaling and cancer. *Cancer Cell*. 2009. 4:167-174.

- McDanel TG. MicroRNA: Mechanism of gene regulation and application to livestock. *J. Anim. Sci.* 2009. 87(E. Suppl.):E21–E28.
- Watson et al. *Molecular Biology of the Gene*, Sixth Edition, 2008. Watson JD, Baker TA, Bell SP, Gann A, Levine M, Losick R. (Benjamin Cummings, San Francisco).

# Unit - 8

---

## Chromosomes

---

### Structure of the Unit

- 8.0 Objective
- 8.1 Introduction
- 8.2 Chromosome
  - 8.2.1 History of Chromosome
  - 8.2.2 Size and shape of Chromosome
  - 8.2.3 Structure of Chromosome
  - 8.2.5 Autosome and Sex Chromosome
  - 8.2.6 Centromere
  - 8.2.7 Telomeres
- 8.3 Kinds of Chromosomes
- 8.4 Chromatin
  - 8.4.1 DNA
  - 8.4.2 Histones
  - 8.4.3 Non-histones
- 8.5 Solenoid model
  - 8.5.1 Types of chromatin
- 8.6 C-value paradox
- 8.7 Karyotype
- 8.8 Chromosome Banding
- 8.9 Summary
- 8.10 Glossary
- 8.11 Self-Learning Exercise
- 8.12 References

---

### 8.0 Objective

---

After going through this unit you will be able to understand:



- Chromatin organization in dividing and non-dividing cells
- Structure of chromosomes.
- Solenoid model
- Importance of C-value paradox,
- Centromere and telomere
- Karyotype, banding techniques.

---

## 8.1 Introduction

---

DNA stands for deoxyribonucleic acid and this is one of the most important kinds of molecules found in living organisms. DNA macromolecules contain instructions that determine the chemistry of the cell, as the production of different proteins in the cell is decided by the information contained in the DNA. Chromatin is a complex of macromolecules found in cells, consisting of DNA, protein and RNA. The primary functions of chromatin are:

- 1) To package DNA into a smaller volume to fit in the cell.
- 2) To reinforce the DNA macromolecule to allow mitosis
- 3) To prevent DNA damage.
- 4) To control gene expression and DNA replication.

The primary protein components of chromatin are histones that compact the DNA. Chromatin is only found in eukaryotic cells (cells with defined nuclei). In eukaryotes, the nucleus of every cell has several thread-like structures called chromosomes which are made up of DNA and proteins. However, in prokaryotes, the chromosome consists of a molecule of DNA which is in close contact with other components of the cell.

Every organism has a specific genome. The haploid set of DNA in an organism is called a genome. In fact, a genome is composed of long DNA molecules that are, in turn, the main components of chromosomes. Each chromosome contains one DNA molecule carrying many genes, which are responsible for characteristics of the organisms.

---

## 8.2 Chromosome

---

**8.2.1 History of Chromosome:** German biologist Walter Flemming in the early 1880s revealed that during cell division the nuclear material organize themselves into visible thread like structures which were named as

chromosomes and stains deep with basic dyes. The term chromosome was coined by W. Waldeyer in 1888. Chrome is coloured and soma is body, hence they mean “colored bodies” and can be defined as higher order organized arrangement of DNA and proteins. Chromosomes are the structures that contain the genetic material. It contains many genes or the hereditary units, regulatory elements and other nucleotide sequences. Chromosomes also contain DNA-bound proteins, which serve in packaging the DNA and control its functions. Chromosomes vary both in number and structure among organisms. They are complexes of DNA and proteins. The genome comprises all the genetic material that an organism possesses. In bacteria, it is typically a single circular chromosome while in eukaryotes, it refers to one complete set of nuclear chromosomes. The number of chromosomes is characteristic of every species. Benden and Bovery in 1887 reported that the number of chromosomes in each species is constant. W.S. Sutton and T. Boveri in 1902 suggested that chromosomes are the physical structures which acted as messengers of heredity.

### **8.2.2 Size and shape of Chromosome**

The size of chromosome is normally measured at mitotic metaphase and may be as short as  $0.25\mu\text{m}$  in fungi and birds to as long as  $30\mu\text{m}$  in some plants. However, most mitotic chromosome falls in the range of  $5\mu\text{m}$  in man and  $8-12\mu\text{m}$  in maize. The monocots contain large sized chromosomes as compared to dicots. Organisms with less number of chromosomes contain comparatively large sized chromosomes. The chromosomes in set vary in size. The shape of the chromosome changes from phase to phase in the continuous process of cell growth and cell division. During the resting/interphase stage of the cell, the chromosomes occur in the form of thin, coiled, elastic and contractile, thread like stainable structures, the chromatin threads. In the metaphase and the anaphase, the chromosome becomes thick and filamentous. Each chromosome contains a clear zone, known as centromere or kinetochore, along their length.

In species, chromosomes may differ considerably in size and may be categorized in groups. For example, in humans, the chromosomes are placed into seven groups from A to G. The largest chromosome is placed in group A and the smallest chromosome in group G. Between organisms, the size differences of chromosomes can be many fold and such differences even exist between species. Chromosomes can be observed inside the nucleus as thread like structures that become visible under the light microscope when the cell is stained with certain dyes. The number of chromosomes in each cell of a

particular species is always constant. Chromosomes are found to exhibit a characteristic splitting behaviour in which each daughter cell formed by cell division receives an identical complement of chromosomes. There is close relationship between the chromosomes and the DNA as the chromosomes contain DNA and proteins. While the amount of DNA per cell is constant, the amount and kinds of chromosomal proteins differ greatly from one cell type to another.

### **8.2.3 Structure of Chromosome**

A chromosome at mitotic metaphase consists of two symmetrical structures called chromatids. Each chromatid contains a single DNA molecule and both chromatids are attached to each other by centromere and become separated at the beginning of anaphase.

The spindle fibres act as molecular strings and are attached to chromosomes during cell division at a specialized region called centromere. It appears as a constriction that divides the chromosome into two arms ( the shorter is called p and the larger is called q ). Centromere in a chromosome contain specific DNA sequences with special proteins bound to them, forming a disc shaped structure, called kinetochore. In electron microscope the kinetochore appears as a plate or cup like disc, 0.20-0.25  $\mu$ m, in diameter situated upon the primary constriction or centromere. The chromosomes of most organisms contain only one centromere and are known as monocentric chromosomes. Telomere is the chromosomal ends which prevents other chromosomal segments to be fused with it. Besides the primary constrictions or centromeres, chromosomes also possess secondary constriction at any point of the chromosome and are constant in their position and extent. These constrictions are helpful in identifying particular chromosomes in a set. Chromosomes also contain nucleolar organizers which are certain secondary constrictions that contain the genes coding for 5.8S, 18S and 28S ribosomal RNA and induce the formation of nucleoli. Sometimes the chromosomes bear round, elongated or knob like appendages known as satellites. The satellite remains connected with the rest of the chromosomes by a thin chromatin filament.

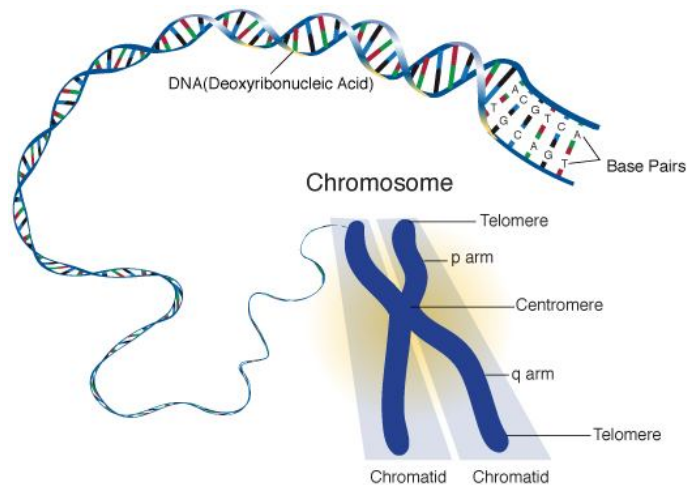

**Figure1: Structure of Chromosome**

### 8.2.4 Chromosome number

There are normally two copies of each chromosome present in every somatic cell. The number of unique chromosomes (N) in such a cell is known as its haploid number, and the total number of chromosomes (2N) is its diploid number. The suffix 'ploid' refers to chromosome 'sets'. The haploid set of the chromosome is also known as the genome. Structurally, eukaryotes possess large linear chromosomes unlike prokaryotes which have circular chromosomes. In Eukaryotes other than the nucleus chromosomes are present in mitochondria and chloroplast too. The number of chromosomes in each somatic cell is same for all members of a given species.

### 8.2.5 Autosome and Sex Chromosome

In a diploid cell, there are two of each kind of chromosome (termed homologous chromosomes) except the sex chromosomes. In humans one of the sex has two of the same kind of sex chromosomes and the other has one of each kind. In humans there are 23 pairs of homologous chromosomes ( $2n=46$ ). The human female has 44 non sex chromosomes, termed autosomes and one pair of homomorphic sex chromosomes given the designation XX. The human male has 44 autosomes and one pair of heteromorphic sex chromosomes, one X and one Y chromosome.

### 8.2.6 Centromere

Centromere refers to the most prominent region of condensed mitotic chromosomes called the primary constriction. This region was initially called centromere as it was invariably located in the middle between the ends of two chromosome arms. Later, the term was extended to describe the primary

constriction of all mitotic chromosomes even when it is not located in a central position. Centromeres have multiple roles during mitosis and are responsible for the accurate segregation of the replicated chromosome during mitosis and enabling the equal distribution of genetic material during cell division. When chromosomes are stained they typically show a dark-stained region that is the centromere. The actual location where the attachments of spindle fibres occur is called the kinetochore and is composed of both DNA and protein. On either side of the centromere, is a trilaminar plate structure called kinetochore. It is a multiprotein complex located at the surface of the chromosomes that binds spindle microtubules and regulates chromosome movement in mitosis. It is also the final site of sister chromatid pairing before segregation takes place. The centromere and the kinetochore help in ensuring the proper orientation of chromosomes at metaphase. Microtubules are attached to the kinetochores. Though centromeres have been conserved throughout evolution, they show structural variability and are classified into two different types. Centromeres may be diffused as is found in many arthropods and plants (*Luzula*) or localized as are generally present in eukaryotes. In diffused centromeres, spindle microtubules attach along the entire length of the chromatids while in localized centromeres, there is single region of attachment for spindle microtubules.

### **8.2.7 Telomeres**

The ends of linear chromosomes are called telomeres. These specialized structures play important role in protecting the ends of chromosomes from attack by nuclease enzymes. They also prevent the chromosomes from joining together as the broken chromosomes attach immediately. Moreover, extreme 5'-terminus of a linear DNA molecule comprises an RNA primer that is not replaced with DNA. A telomere is specialized to make the natural end of a linear chromosome behave differently from a simple double-stranded DNA break. Telomeres, or ends of eukaryotic chromosomes, contain no genes. Instead they are composed of many repeats of short, GC rich sequences. The exact sequence of the repeat in a telomere is species-specific. These repeats are added to the very 3'-ends of DNA strands, by semi-conservative replication by telomerase. Telomeric DNA is made up of multiple copies of a short sequence, 5'-AGGGTT-3' in humans which is repeated possibly a thousand times or more at the extreme ends of each chromosomal DNA molecule. Actual structure is different for each telomere. 5'-3' strand is G rich while 3'-5' strand is C rich. The repeat sequences act as binding sites for telomeric-specific proteins. The bound

proteins probably act as a cap, preventing the ends of the chromosomes being degraded or fusing with other chromosomes. The telomerase enzyme consists of a protein subunit and an RNA molecule. Telomerase RNA contains at one position a short sequence identical to one or more repeat sequences of the C-rich strand of telomere. It acts as a template for synthesis of repeat sequence of G-rich strand. Thus the shortening effect of DNA replication can be counterbalanced by repeatedly extending the G-rich strand.

Telomere is very important part of a chromosome. It is required for the complete replication of the chromosome. It forms caps that protect the chromosome from nuclease. It prevents the ends of chromosomes from fusing with one another. It facilitates interaction between the ends of the chromosome and the nuclear envelope in some types of cells.

---

### 8.3 Kinds of Chromosomes

---

**On the bases of position of centromere the chromosomes are classified into various types:**

1. Telocentric (centromere at one end), 2. acrocentric (centromere close to one end), 3. submetacentric (centromere close to middle) and 4. metacentric (centromere exactly in the middle). However, there are species in plants and animals that have holocentric chromosomes which have kinetic activity diffused throughout the length of the chromosome.

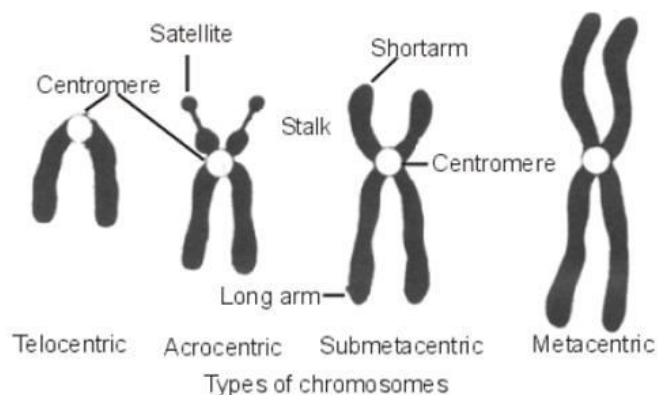

---

### 8.4 Chromatin

---

Chemically chromatin is consisted of DNA, RNA, protein and inorganic ions  $Mg^{2+}$ ,  $Ca^{2+}$ . The protein of chromatin could be of two types: histones and non histones.

### 8.4.1 DNA

DNA is the most important chemical component of chromatin, since it plays central role of controlling heredity and is most conveniently measured in picograms. In addition to describing the genome of an organism by its number of chromosomes, it is also described by the amount of DNA in a haploid cell. Lower eukaryotes in general have less DNA, such as nematode *Caenorhabditis elegans* which has 20 times more DNA than *E. coli*. Vertebrates have greater DNA content about 3pg, in general about 700 times more than *E. coli*. *Salamander amphiuma* has a very high DNA content of about 84pg. Man has about 3pg of DNA per haploid genome.

### 8.4.2 Histones

Histones are basic proteins as they are enriched with basic proteins arginine and lysine. At physiological pH they are cationic and can interact with anionic nucleic acids. They form a highly condensed structure. The histones are of five types called H1, H2A H2B, H3, and H4-which are very similar among different species of eukaryotes and have been highly conserved during evolution. H1 is the least conserved among all and is also loosely bound with DNA. H1 histone is absent in *Sacharomyces cerevisiae*. All histones can be separated by gel electrophoresis. Histones are basic proteins as these contain high proportion of basic amino acids.

### 8.4.3 Non-histones

In addition to histones the chromatin comprise of many different types of non-histone proteins, which are involved in a range of activities, including DNA replication and gene expression. They display more diversity or are not conserved. They may also differ between different tissues of same organism. Non-histone proteins associated with DNA are acidic in nature and include various enzymes and proteins involved in the process of replication and transcription.

Roger Kornberg in 1974 described the basic structural unit of chromatin which is called the nucleosome. DNA is folded into bead like structures called nucleosomes, which are repeating units of chromosome structure. These units are remarkably uniform in size, about 11 nm in diameter.

In general terms, there are three levels of chromatin organization:

1. DNA wraps around histone proteins forming nucleosomes; the "beads on a string" structure (euchromatin).

2. Multiple histones wrap into a 30 nm fibre consisting of nucleosome arrays in their most compact form (heterochromatin).
3. Higher-level DNA packaging of the 30 nm fibre into the metaphase chromosome (during mitosis and meiosis).

---

## 8.5 Solenoid model

---

The long sized DNA are accommodated in small areas (about 1  $\mu\text{m}$  in *E. coli* and 5  $\mu\text{m}$  nucleus in human beings) only through packing or compaction. The packaging of DNA in nucleosome is explained with solenoid model. DNA is acidic due to presence of a large number of phosphate groups. Compaction occurs by folding and attachment of DNA with basic proteins, non-histone in prokaryotes and histones in eukaryotes.

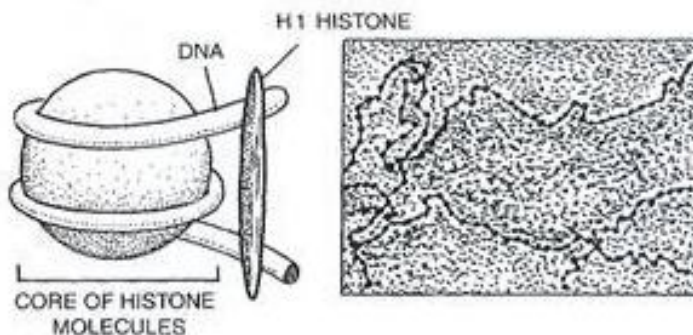

Nucleosome. A, Components of nucleosome. B, Beads on string appearance of nucleosome chain.

The packaging of DNA in nucleosome is carried out with help of histones. Out of five types of histone proteins, four ( $\text{H}_2\text{A}$ ,  $\text{H}_2\text{B}$ ,  $\text{H}_3$  and  $\text{H}_4$ ) occur in pairs to produce histone octamer, called nu body or core of nucleosome. Their positively charged ends (due to basic amino acids) are towards the outside. They attract negatively charged strands of DNA.

About 166 bp of DNA is wrapped over nu body for 1 $\frac{1}{2}$  turns to form nucleosome of size 110 x 60A (11x6 nm). DNA connecting two adjacent nucleosomes is called interbead or linker DNA. It bears  $\text{H}_1$  histone protein (called plugging protein and act as marker protein). Length of linker DNA is varied (about 145A with 70 bp). Nucleosome and linker DNA together constitute chromatosome.

Nucleosome chain gives a beads on string appearance under electron microscope. The beaded string is coiled to form cylindrical coil or solenoid having 6 nucleosomes per turn. Actually the nucleosomal organisation has



approximately 10nm thickness, which gets further condensed and coiled to produce a solenoid of a 30nm diameter. This solenoid structure undergoes further coiling to produce a chromatin fibre of 30-80 nm and then a chromatid of 700 nm.

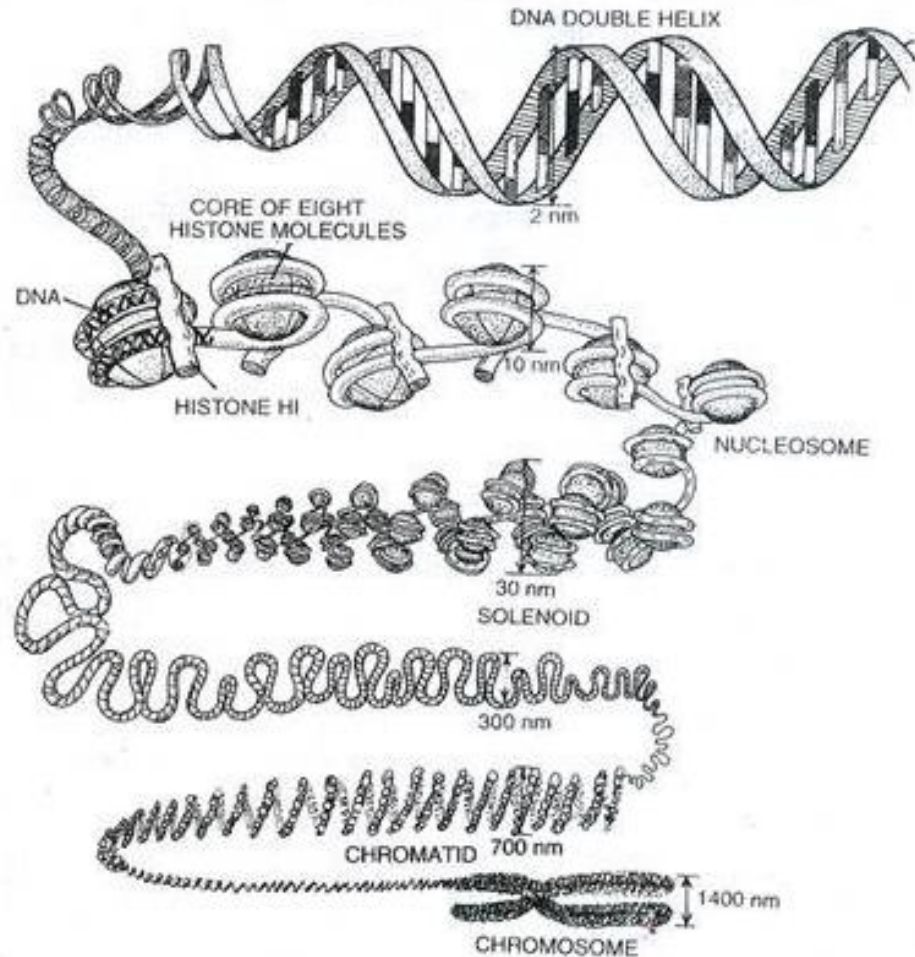

Solenoid model of folding and super folding of basic chromatin components to form eukaryotic chromosome.

DNA (2 nm diameter) → nucleosome (10 nm diameter) → solenoid (30 nm diameter) → chromatin fibre (30-80 nm diameter) → chromatid (700 nm diameter) → chromosome (1400 nm diameter)

Chromatin is held over a scaffold of nonhistone chromosomal or NHC proteins. At some places chromatin is densely packed to form darkly staining heterochromatin. At other places chromatin is loosely packed. It is called euchromatin. Euchromatin is lightly stained.

### 8.5.1 Types of chromatin

Two types of chromatin are found: 1. Euchromatin and 2. Heterochromatin

1. **Euchromatin:** The lightly-stained regions in chromosome when stained with basic dyes are called euchromatin and contain single-copy of genetically-active DNA. The extent of chromatin condensation varies during the life cycle of the cell and plays an important role in regulating gene expression. It is transcriptionally active chromatin. In the interphase of cell cycle the chromatin are decondensed and known as euchromatin leading to gene transcription and DNA replication.
2. **Heterochromatin:** The word heterochromatin was coined by Emil Heitz based on cytological observations. They are highly condensed and ordered areas in nucleosomal arrays. About 10% of interphase chromatin is called heterochromatin and is in a very highly condensed state that resembles the chromatin of cells undergoing mitosis. They contain a high density of repetitive DNA found at centromeres and telomeres form heterochromatin. Heterochromatin are of two types, the constitutive and facultative heterochromatin. The regions that remain condensed throughout the cell cycle are called constitutive heterochromatin whereas the regions where heterochromatin condensation state can change are known as facultative. Heterochromatin is transcriptionally inactive and late replicating or heteropycnotic. Constitutive heterochromatin is found in the region that flanks the telomeres and centromere of each chromosome and in the distal arm of the Y chromosome in mammals. Constitutive heterochromatin possesses very few genes and they also lead to transcriptional inactivation of nearby genes. This phenomenon of gene silencing is known as “position effect”. Constitutive heterochromatin also inhibits genetic recombination between homologous repetitive sequences circumventing DNA duplications and deletion. Whereas facultative heterochromatin is chromatin that has been specifically inactivated during certain phases of an organism’s life or in certain types of differentiated cells. Dosage compensation of X-chromosome or X-chromosome inactivation in mammals is an example of such heterochromatin (Karp 2010). Heterochromatin spreads from a specific nucleation site, causing silencing of most of the X chromosome, thereby regulating gene dosage.

---

## 8.6 C-value paradox

---

Genome size is normally expressed as amount of DNA per haploid set of chromosomes. It is referred to as the 'C value' of the organism. The amount of DNA per diploid cell is the '2C value'. Since genome refers to all DNA present in the haploid set of chromosomes, so 'C' refers to the amount of DNA present in picograms (i.e. grams  $\times 10^{-12}$ ) per haploid set of chromosomes. Eukaryotic organisms appear to have 2-10 times as many genes as prokaryotes, But, they have many orders of magnitude more DNA in the cell. Furthermore, the amount of DNA per genome is correlated not with the presumed evolutionary complexity of a species hence the amount of DNA is not correlated with the number of chromosomes. C value paradox can be defined as the amount of DNA in the haploid cell of an organism is not related to its evolutionary complexity.

---

## 8.7 Karyotype

---

A karyotype is a micrograph in which all the chromosomes within a single cell are arranged in a standard fashion to give pictorial or photographic representation. The chromosomes are usually arranged in order of size and numbered from largest to smallest. Sex chromosomes are designated with letters. For example, in humans, there are 23 pairs of chromosomes. Of these, 22 pairs are of autosomes and a pair is of sex chromosomes. The autosomes are numbered from 1 to 22 according to their size and shape. The sex chromosomes are designated as X and Y. Generally, the chromosomes in actively dividing cells can be karyotyped.

While preparing a karyotype, the chromosomes are aligned with short arms on top and long arm on the bottom. In 1956, Tijo and Levan determined correct diploid number of human chromosomes ( $2n=46$ ). In humans, a system is used for identifying chromosome based on chromosomal size, position of centromere and banding patterns. Autosomes are numbered first on the basis of length, with X and Y chromosomes identified separately. Insertions, deletions and changes in chromosome number can be detected by the skilled cytogeneticist, but correlating these with specific phenotypes is difficult.

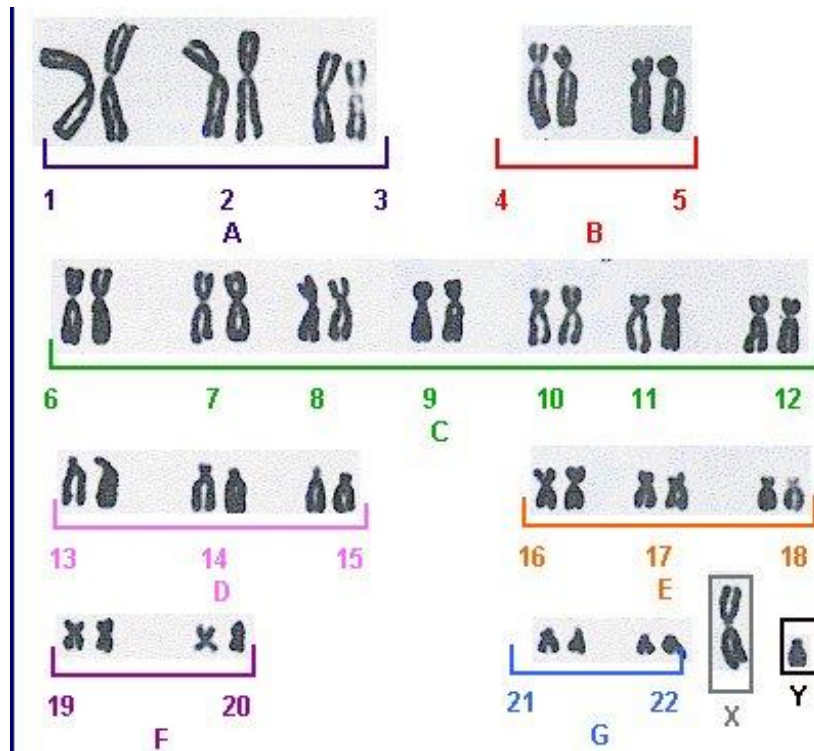

**Fig.5 Human chromosomes are divided into 7 groups & sex chromosomes**

A 1-3 Large metacentric 1,2 or submetacentric, B 4,5 Large submetacentric, all similar, C 6-12, X Medium sized, submetacentric – difficult, D 13-15 medium-sized acrocentric plus satellites, E 16-18 short metacentric 16 or submetacentric 17,18, F 19-20 Short metacentrics, G 21,22,Y Short acrocentrics with satellites. Y no satellites.

## 8.8 Chromosome Banding

Special staining techniques have revealed intricate sets of bands (transverse stripes) on chromosomes in many different organisms. The bands represent useful landmarks because their positions and sizes are highly chromosome-specific. There are Q bands produced by quinacrine hydrochloride, G bands produced by Giemsa stain and R bands produced by reversed Giemsa. Chromosome banding is of fundamental importance for chromosome identification on the basis of longitudinal differentiation and is thus very useful for elucidating the evolutionary relationships in organisms.

For chromosome characterization, four distinct kinds of bands can be recognised. These bands are specific to euchromatin, heterochromatin, nucleolar organizer regions and kinetochores. Euchromatic bands (including Q-, G and R-bands) form a pattern of positive (darkly staining or brightly fluorescent) and negative (weakly staining or dimly fluorescent) bands

throughout the length of the chromosome of higher vertebrates. Q, G and R bands probably reflect the degree of compactness of the DNA and are never associated with centromeric heterochromatin. Darker bands are found near the centromeres or on the ends (telomeres) of chromosomes. Dark staining areas are heterochromatic while light staining regions are euchromatic. These regions generally remain constant in different cells or individuals of a given species. Euchromatic regions often undergo a regular cycle of contraction and extension.

Heterochromatic bands (C-bands and various more specific types) are specific to heterochromatin and help in chromosome identification in majority of those species that lack euchromatic bands. Heterochromatic bands are highly localized, usually around the centromeres, but also occur elsewhere on the chromosomes. They correspond to classically defined heterochromatin, that is, regions of chromosomes that normally remain condensed throughout interphase. Nucleolar organizer regions (NORs) are the regions of chromosome that contain genes for ribosomal RNA and are responsible for the formation of nucleoli in the interphase nuclei. Kinetochores are the special regions by which chromosomes are attached to the spindle during cell division and these can be demonstrated through immunolabelling. Banding patterns have revealed that chromosomes are segmented into a series of regions having distinctive properties in respect of DNA base composition, time of DNA replication and gene content.

Thus, the chromosome bands are, in fact, visible expression of the functional and compositional compartmentalization of chromosomes. Natural banding patterns become readily visible in polytene chromosomes and can serve as landmarks such as in fruit fly, *Drosophila melanogaster*. The diploid chromosome number in this species is eight ( $2n=8$ ) and these eight chromosomes are present in most of the cells. However, in the cells of the special organs that contain the polytene chromosomes, certain interesting peculiarities exist. The banding pattern of each chromosome is unique. The bands do not represent genes as in any chromosomal region of *Drosophila*, there are more genes than the number of polytene bands.

---

## 8.9 Summary

---

The length of DNA in the nucleus is far greater than the size of the compartment in which it is contained. To fit into this compartment the DNA has to be condensed in some manner. The degree to which DNA is condensed

is expressed as its packing ratio. Packing ratio - the length of DNA divided by the length into which it is packaged. To achieve the overall packing ratio, DNA is not packaged directly into final structure of chromatin. Instead, it contains several hierarchies of organization. The first level of packing is achieved by the winding of DNA around a protein core to produce a "bead-like" structure called a nucleosome. This structure is invariant in both the euchromatin and heterochromatin of all chromosomes. The second level of packing is the coiling of beads in a helical structure called the 30 nm fiber that is found in both interphase chromatin. The final packaging occurs when the fiber is organized in loops, scaffolds and domains that give a final packing ratio of about 1000 in interphase chromosomes and about 10,000 in mitotic chromosomes.

---

## 8.10 Glossary

---

- **DNA:** Deoxyribose Nuclie Acid
- **C Value:** Genome size is normally expressed as amount of DNA per haploid set of chromosomes.
- **Euchromatin:** The lightly-stained regions in chromosome when stained with basic dyes are called euchromatin.
- **Heterochromatin:** They are highly condensed and ordered areas in nucleosomal arrays.

---

## 8.11 Self-Learning Exercise

---

### Section -A (Very Short Answer Type)

1. Which answer is in order from SMALLEST to BIGGEST?  
A. gene, chromosome, cell  
B. chromosome, gene, cell  
C. nucleus, gene, chromosome  
D. None
2. How many chromosomes do humans have in their body cells?
3. A nucleosome consists of.....
4. Define Cvalue paradox?
5. How many type of histone protein are found in nucleosome?

### Section -B (Short Answer Type)

1. Draw well labelled diagram of solenoid structure.
2. Explain nucleosome.
3. What is karyotyping?
4. Explain chromosome banding.

### Section -C (Long Answer Type)

1. Explain in detail about karyotyping?
2. Discuss about structure of chromosome.
3. Write short notes-
  - (a) Telomere
  - (b) Centromere

### Answer Key of Section-A

1. A
2. 46
3. Histone, Nucleoid Material
4. Genome size is normally expressed as amount of DNA per haploid set of chromosomes.
5. 6

---

## 8.12 References

---

- D. C. Gautam, "Chromosome organization and composition", Cell Biology and Genetics
- NPTEL – Biotechnology – Cell Biology

## Unit – 9

---

# **Genome expression analysis: FISH, GISH, M-FISH, Minichromosomes and Giant chromosomes Gene expression; Process of gene expression: Translation, Transcription; Gene control regions; Gene expression analysis techniques; Giant chromosomes Minichromosomes**

---

### **Structure of the Unit**

- 9.0 Objectives
- 9.1 Introduction of gene expression
- 9.2 Process of gene expression
  - 9.2.1 Transcription
    - 9.2.1.1 Initiation
    - 9.2.1.2 Elongation
    - 9.2.1.3 Termination
    - 9.2.1.4 Processing
  - 9.2.2 Translation
    - 9.2.2.1 Initiation
    - 9.2.2.2 Elongation
    - 9.2.2.3 Termination
    - 9.2.2.4 Post-translation processing of the protein
- 9.3 Gene control regions
  - 9.3.1 Start site**
  - 9.3.1 A promoter**
  - 9.3.1 Enhancers**



### 9.3.1 Silencers

## 9.4 Gene expression analysis techniques

### 9.4.1 Fluorescent in situ hybridization (FISH)

### 9.4.2 Multi color fluorescent in situ hybridization (M-FISH)

### 9.4.3 Genomic in situ hybridization (GISH)

## 9.5 Mini chromosomes

## 9.6 Giant Chromosomes

## 9.7 Summary

## 9.8 Glossary

## 9.9 Self-Learning Exercise

## 9.10 References

---

## 9.0 Objectives

---

After going through this unit you will be able to understand

- About the gene expression.
  - Process of gene expression (Transcription and Translation).
  - Genome analysis techniques
  - FISH
  - M-FISH
  - Mini chromosomes
  - Giant chromosomes
- 

## 9.1 Introduction

---

Gene expression is a highly regulated mechanism that controls the function and adaptability of all living cells including prokaryotes and eukaryotes. Gene expression is the procedure by which information from a gene is used in the synthesis of a functional gene product. These products are often proteins, but in non-protein coding genes such as transfer RNA (tRNA) or small nuclear RNA (snRNA) genes, the product is a functional RNA. Several techniques exist for studying and quantifying gene expression and its regulation. Some of these techniques are old and well established while others are relatively new, multiplex techniques. The field of gene expression analysis has undergone major advances in biomedical research.

---

## 9.2 Process of gene expression

---

### 9.2.1 Transcription

#### 9.2.1.1 Initiation

#### 9.2.1.2 Elongation

#### 9.2.1.3 Termination

#### 9.2.1.4 Processing

### 9.2.2 Translation

#### 9.2.2.1 Initiation

#### 9.2.2.2 Elongation

#### 9.2.2.3 Termination

#### 9.2.2.4 Post-translation processing of the protein

Some genes are responsible for the production of other forms of RNA that play a role in translation, including transfer RNA (t-RNA) and ribosomal RNA (r-RNA).

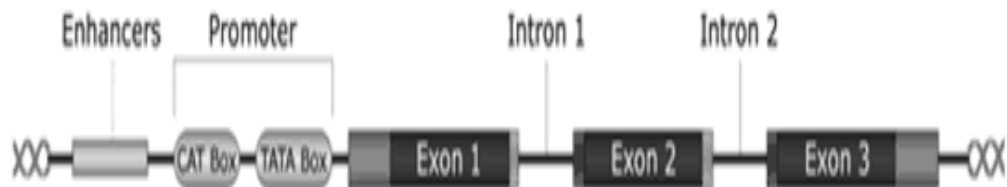

**Figure 1:** A structural gene

**Exons:** Exons code for amino acids and communally conclude the amino acid sequence of the protein product.

**Introns:** Introns are portions of the gene that do not code for amino acids, and are removed (spliced) from the mRNA molecule before translation

**The process of gene expression involves two main stages:**

**9.2.1 Transcription:** Transcription is the process of RNA synthesis, inhibited by the communication of promoters and enhancers. Several different types of RNA are produced, including messenger RNA(mRNA), which specify the sequence of amino acids in the protein product, and transfer RNA (tRNA) and ribosomal RNA (rRNA), which play a role in the translation process.

Transcription involves four steps:

**9.2.1.1 Initiation:** The DNA molecule unwinds and separates to form a small open complex. RNA polymerase binds to the promoter of the template strand. The synthesis of RNA proceeds in a 5' to 3' direction, so the template strand must be 3' to 5'.

**9.2.1.2 Elongation:** RNA polymerase moves along the template strand, synthesizing an mRNA molecule. In prokaryotes RNA polymerase is a holoenzyme consisting of a number of subunits, including a sigma factor (transcription factor) that recognizes the promoter. In eukaryotes there are three RNA polymerases: I, II and III. The process includes a proofreading mechanism.

**9.2.1.3 Termination:** In prokaryotes there are two ways in which transcription is terminated. In Rho-dependent termination, a protein factor called "Rho" is responsible for disrupting the complex involving the template strand, RNA polymerase and RNA molecule. In Rho-independent termination, a loop forms at the end of the RNA molecule, causing it to detach itself. Termination in eukaryotes is more complicated, involving the addition of additional adenine nucleotides at the 3' of the RNA transcript (a process referred to as polyadenylation).

**9.2.1.4 Processing:** After transcription the RNA molecule is processed in a number of ways: introns are removed and the exons are spliced together to form a mature mRNA molecule consisting of a single protein-coding sequence. RNA synthesis involves the normal base pairing rules, but the base thymine is replaced with the base uracil.

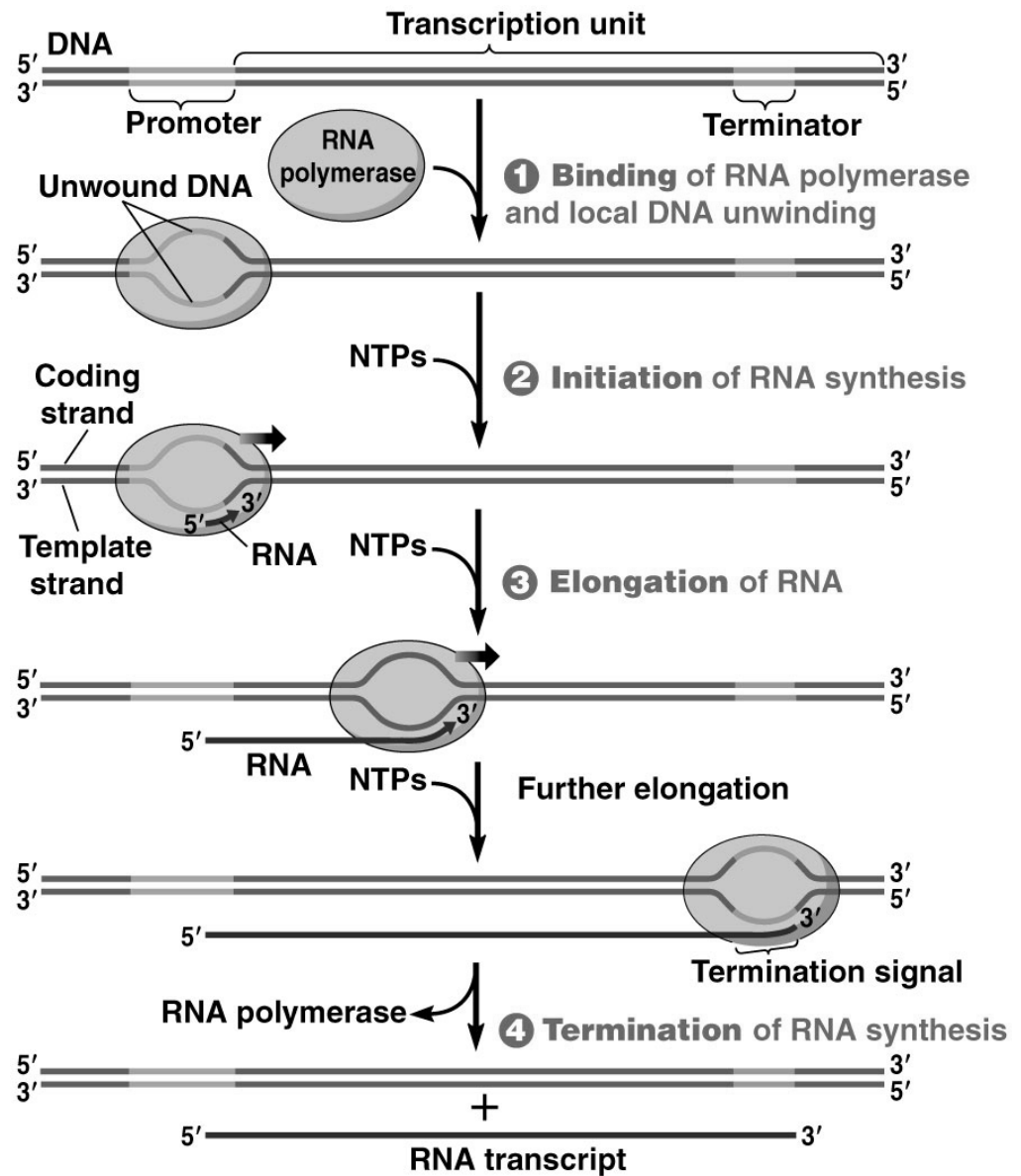

**Figure 2: Process of transcription**

**9.2.2 Translation:** In translation the mature mRNA molecule is used as a template to assemble a series of amino acids to produce a polypeptide with a specific amino acid sequence. The complex in the cytoplasm at which this occurs is called ribosome. Ribosome is a mixture of ribosomal proteins and ribosomal RNA (rRNA), and consists of a large subunit and a small subunit.

Translation involves four steps:

**9.2.2.1 Initiation.** The small subunit of the ribosome binds at the 5' end of the mRNA molecule and moves in a 3' direction until it meets a start codon (AUG).

It then forms a complex with the large unit of the ribosome complex and an initiation tRNA molecule.

**9.2.2.2 Elongation.** Subsequent codons on the mRNA molecule determine which tRNA molecule linked to an amino acid binds to the mRNA. An enzyme peptidyl transferase links the amino acids together using peptide bonds. The process continues, producing a chain of amino acids as the ribosome moves along the mRNA molecule.

**9.2.2.3 Termination.** Translation is terminated when the ribosomal complex reached one or more stop codons (UAA, UAG, UGA). The ribosomal complex in eukaryotes is larger and more complicated than in prokaryotes. In addition, the processes of transcription and translation are divided in eukaryotes between the nucleus (transcription) and the cytoplasm (translation), which provides more opportunities for the regulation of gene expression.

#### 9.2.2.4 Post-translation processing of the protein

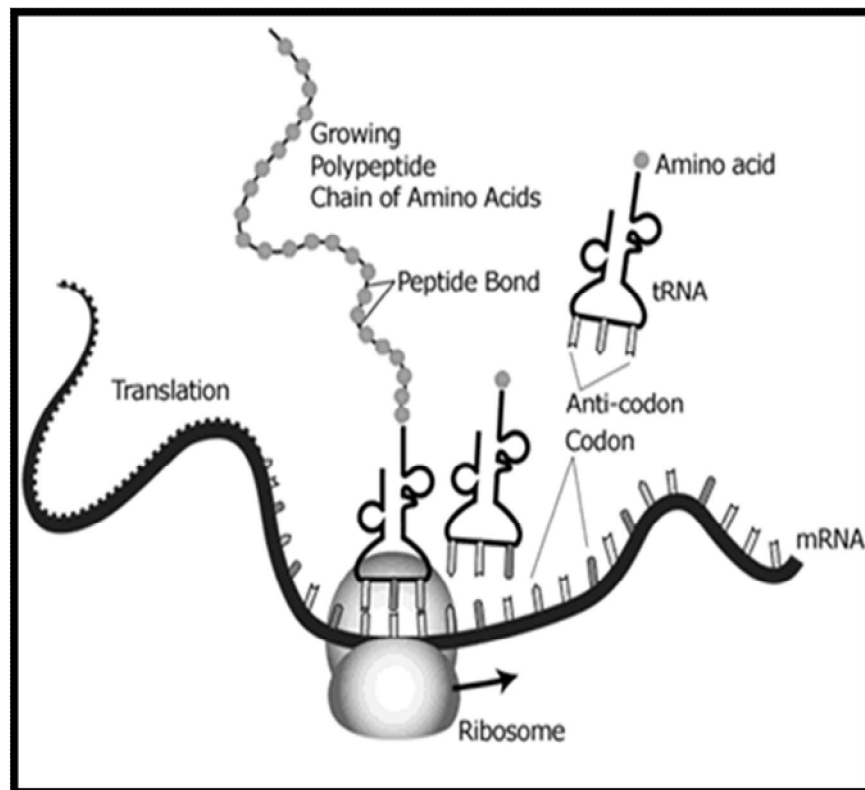

**Figure 3: Process of Translation**

---

## 9.3 Gene control regions

---

### 9.3.1 Start site

#### 9.3.1 A promoter

#### 9.3.1 Enhancers

#### 9.3.1 Silencers

#### 9.3.1 Start site.

A start site for transcription.

#### 9.3.2 A promoter

A region a few hundred nucleotides 'upstream' of the gene (toward the 5' end). It is not transcribed into mRNA, but plays a role in controlling the transcription of the gene. Transcription factors bind to specific nucleotide sequences in the promoter region and assist in the binding of RNA polymerases.

#### 9.3.3 Enhancers

Some transcription factors (called activators) bind to regions called 'enhancers' that increase the rate of transcription. These sites may be thousands of nucleotides from the coding sequences or within an intron. Some enhancers are conditional and only work in the presence of other factors as well as transcription factors.

#### 9.3.4 Silencers

Some transcription factors (called repressors) bind to regions called 'silencers' that depress the rate of transcription.

---

## 9.4 Gene expression analysis techniques

---

Measuring the expression of most or all of the genes in a biological system raises major analytic challenges. Analytical methods may be used to examine mRNA expression levels or differential mRNA expression. Some examples of these techniques are listed below.

### 9.4.1 Fluorescence *in Situ* Hybridization (FISH)

### 9.4.2 Multicolour fluorescence *in situ* hybridization (M-FISH)

### 9.4.3 Genomic *in situ* hybridization (GISH)

#### 9.4.1 Fluorescence *in Situ* Hybridization (FISH)

Classical karyotyping uses dyes that differentially stain the chromosomes. Thus, each chromosome is identified by its banding pattern. However,

traditional banding techniques are limited to the identification of large and relatively simple changes.

*In situ* hybridization is the most sensitive and specific means of identifying the location of genes on chromosomes. In addition, using chromosome- and gene-specific probes, numerical and structural aberrations can be analyzed within individual cells. Thus, *in situ* hybridization has applications in the diagnosis of genetic disease and in the identification of gene deletions, translocations, and amplification. FISH techniques are proving highly successful in the identification of chromosomal alterations which could not be resolved by traditional approaches.

Fluorescence *in Situ* Hybridization (FISH) is used in the Analysis of Genes and Chromosomes. Fluorescence *in situ* hybridization is the most direct way of determining the linear order of genes on chromosomes. By using chromosome- and gene-specific probes, numerical and structural aberrations can also be analyzed within individual cells. These techniques have a wide variety of applications in the diagnosis of genetic disease and the identification of gene deletions, translocations, and amplifications during cancer development. Nucleic acid probes are labeled nonisotopically by the incorporation of nucleotides modified with molecules such as biotin or digoxigenin. After hybridization of the labeled probes to the chromosomes, detection of the hybridized sequences is achieved by forming antibody complexes that recognize the biotin or digoxigenin within the probe. The hybridization is visualized by using antibodies conjugated to fluorochromes. The fluorescent signal can be detected in a number of ways. If the signal is strong enough, standard fluorescence microscopy can be used. However, data analysis and storage can be improved considerably by the use of digital imaging systems such as confocal laser scanning microscopy or cooled CCD camera.

The major advantages of fluorescence *in situ* hybridization (FISH) are that it is nonisotopic, radioactivity is not required, it is rapid, amenable to computerized storage and manipulation, sensitive, gives accurate signal localization, allows simultaneous analysis of two or more fluorochromes, and provides a quantitative and spatial distribution of the signal.

### **Variations**

**Chromosomal painting:** A technique has been developed that allows investigators to differentiate all of our chromosomes very quickly and accurately by seeing them painted in different fluorescent colors. This

technique allows a scientist or clinician to determine quickly whether any chromosomal anomalies exist, either in number (aneuploidy) or structure (deletions, translocations). The technique, **chromosomal painting**, is a variant of the technique known as **fluorescent in situ hybridization (FISH)**, in which a fluorescent dye is attached to a nucleotide probe that then binds to a specific site on a chromosome and makes itself visible by fluorescence. A whole chromosome can be made visible by this technique if enough probes are available to mark enough of the chromosome. However, there are not enough fluorescent markers known to paint all 24 of our chromosomes (autosomes 1–22, X, Y) a different color. Now, with as few as five different fluorescent markers and enough probes to coat each chromosome, it is possible to make combinations of the different marker dyes so that each chromosome fluoresces a different color. Because the colors are not generally distinguishable by the human eye, they have to be separated by a computer that then assigns each chromosome its own color. The technique works very well. With it, we can rapidly determine any chromosomal anomaly in a given cell. This technique is helpful in clinical diagnosis of various syndromes and diseases, including cancer.

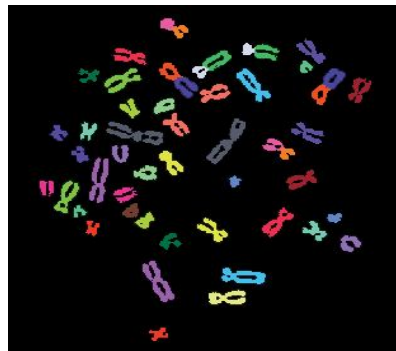

A

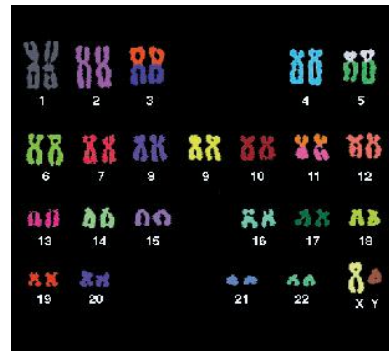

B



C

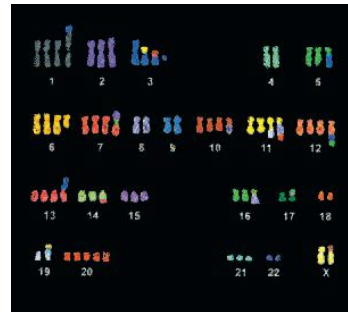

D



**Figure 4:** Chromosomal spreads after treating with probes specific for all human chromosomes and attached to fluorescent tags. Colors are generated by computer. *Left (a, b)* are the spread and karyotype of a normal cell; *right (c, d)* are the same for an ovarian cancer cell with complex chromosomal anomalies.

**9.4.2 Multicolor fluorescence *in situ* hybridization (M-FISH):** Traditional FISH analysis has employed, at most, two colors of detection, red-fluorescing fluorochromes and green-fluorescing fluorochromes. The improvements in fluorescent imaging and development of heartier fluorochromes/dyes have enabled investigators to use several different DNA probes in one experiment. This may involve all or combinations of locus-specific probes and chromosome paints. The value of such experiments lies in the investigator obtaining far more information from one specific cell at one time, rather than carrying out separate experiments on multiple specimens prepared from the same sample, then extrapolating results.

1. Spectral karyotyping (SKY)
2. Multicolor fluorescence *in situ* hybridization (M-FISH)

For both assays, the experimental procedures are identical: commercially available probes for all 24 (human) chromosomes are differentially labeled according to a labeling scheme and hybridized to metaphase spreads for 24 to 48 hr, followed by post-hybridization washes and, if required, antibody detection.

The difference lies in the imaging: spectral karyotyping identifies the differentiation of the chromosomes based on their spectral properties, whereas M-FISH identifies the differentiation of the chromosomes based on that fluorochromes presence or absence when visualized with specific filters. The resulting analysis for both methods is the same, revealing hidden translocations and insertions as well as the chromosomal components of marker chromosomes.

Furthermore, visualization of the resulting fluorescence patterns by computer programs makes these techniques more sensitive than the human eye. These techniques are proving to be highly successful in the identification of new chromosomal alterations that were previously unresolved by traditional approaches

A related technique called *multicolor FISH* can detect chromosomal translocations. The much more detailed analysis possible with this technique

permits detection of chromosomal translocations that banding analysis does not reveal.

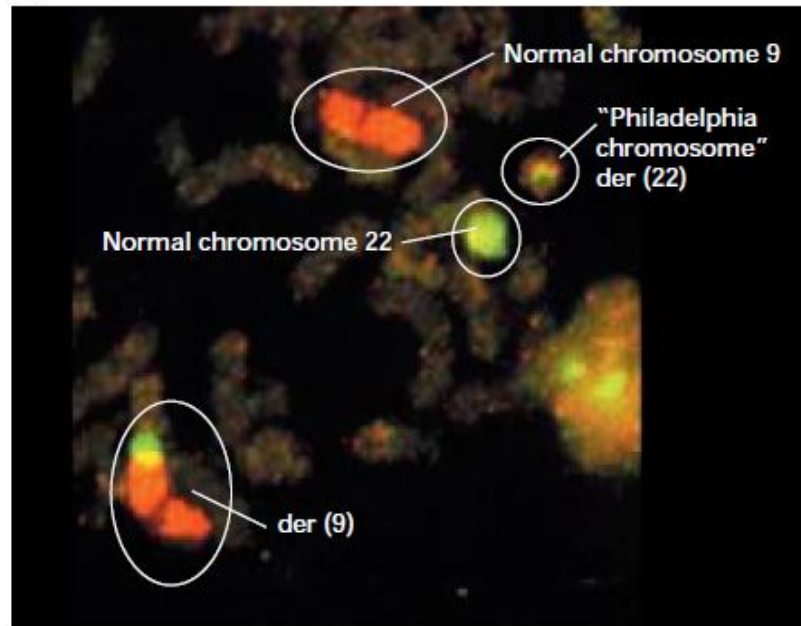

**Figure- 5: Chromosomal translocations can be analyzed using banding patterns and multicolor FISH.** Characteristic chromosomal translocations are associated with certain genetic disorders and specific types of cancers. For example, in nearly all patients with chronic myelogenous leukemia, the leukemic cells contain the Philadelphia chromosome, a shortened chromosome 22 [der (22)], and an abnormally long chromosome 9 [der (9)]. These result from a translocation between normal chromosomes 9 and 22. This translocation can be detected by multicolor FISH

#### **9.4.3 Genomic *in situ* hybridization (GISH)**

Genomic *in situ* hybridization (GISH) involves the extraction of DNA from one organism, labeling this in some way so that it can be detected later *in situ* by a fluorescent dye, and using this as a probe to target cells from another organism prepared using normal cytological squash methods. Those parts of the chromosomes of the target organism that is sufficiently similar to the probe material from probe target complexes which are labeled by the fluorescent dye. Other parts not forming such a complex do not become fluorescent but can be counter stained with a dye of contrasting color.

Early attempts to identify individual chromosomes or genome in cell had to rely on morphology alone, using overall size and the position of the various markers

such as centromeres and secondary constrictions. The development of chromosome banding technique around 1970 represented a tremendous advance, since many more sites can be recognized within a genome, and often each chromosome has a unique pattern of bands.

The first *in situ* hybridization (ISH) studies developed in the late 1960 and 1970 differed from GISH in that the probes were of small specific regions of the genome and labeling was radioactive. They were effectively a controlled variant of chromosome banding, in which the molecular nature of the labeled bands or regions was at least potentially known. The substitution in the 1980 of fluorescence for radio activity in fluorescent *in situ* hybridization (FISH) was an advance over ISH partly because the technique is quicker, safe and cheaper and also because the results can be polychromatic and have a higher resolution. GISH can be considered a further advance over FISH, because in the former whole chromosomes become labeled.

GISH is the highly advanced in many studies like as genome identification and meiotic analysis. GISH is also applicable to cells at interphase as well as those undergoing cell division. GISH was originally developed for animal hybrid cell lines and first used on plants in 1987 at the plant breeding institute, Cambridge.

**Use of genomic *in situ* hybridization:** The uses to which GISH has been put may be placed in four major categories.

1. Chromosome disposition: The concept of chromosomes in a nucleus not being randomly intermingled, but instead occupying discrete chromosomal domains was largely developed in the 1980. GISH based studies mainly relate to sexual or somatic hybrids or to polyploidy, where two or more different genomes occur together in cell. They can be equally informative at interphase or during mitosis. The existence of separate chromosomal or genomic domains is clearly highly significant in several ways like as control of transcription and gene expression, preferential loss of chromosomes in wide sexual or in somatic hybrids, and pairing at meiosis.
2. Genome identification: The use of GISH to label the whole of one genome but none of the other genome in cells with two or more genomes, and with the ability to paint the genomes by different colors.
3. Recognition of parts of genome: GISH is equally effective in detecting odd chromosomes or segments of chromosomes in foreign cells. The

chromosomes fragment as small as 50-100 Mbp should be detectable by GISH. Gish is five times greater than the size detectable by ISH.

4. Meiotic studies: GISH is theoretically and in practice equally as applicable to meiotic as to interphase or mitotic problems, but relatively few studies have so far been made, probably because optimum preparations are less easily obtained. Stages from pachytene onwards are suitable for study by GISH.

---

## 9.5 Mini chromosomes

---

Minichromosomes: A Minichromosome is an extremely small version of a chromosome that has been produced by *de novo* construction using cloned components of chromosomes or through telomere-mediated truncation of endogenous chromosomes. They depend on functional *DnaA* and *DnaC* products, *de novo* protein synthesis and RNA polymerase mediated transcription for initiation of bi-directional replication; thereby resembling their chromosomal counterparts. Minichromosomes are also known to be enriched with transposable or repetitive elements.

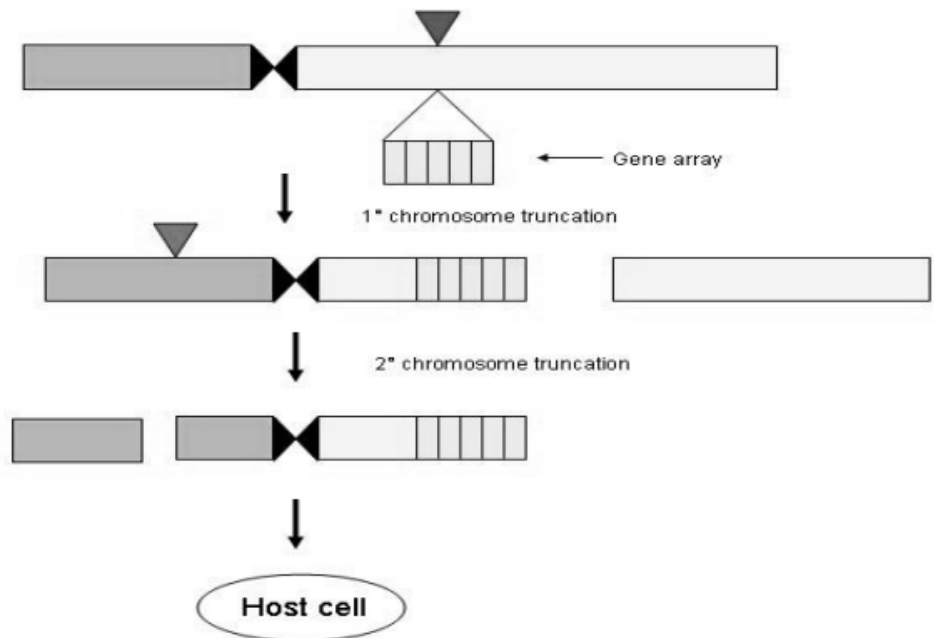

**Figure-6 : Minichromosomes can be produced by telomere mediated chromosome truncation**

Genetic engineering is a powerful tool for improving crop quality and productivity, and reducing labor and resource utilization of farming.

Traditionally genetic engineering is done by either *Agrobacterium*-mediated transformation or direct transformation by particle bombardment using gene gun. These methods have several limitations, since they allow insertion of single or few genes at random genomic positions and require the simultaneous expression of multiple genes; but complex or combined traits cannot be transferred in a coordinated manner. These methods are labour-intensive and time consuming processes and also require highly skilled personal and significant input for desirable results. Furthermore, a high number of phenotypically abnormal plants are recovered and often usefulness of host genome is seriously disturbed. Minichromosome technology provides one solution to the stable expression and maintenance of multiple transgenes in one genome. In addition, plant artificial chromosomes or engineered minichromosomes represent a potentially powerful research tool for understanding chromosome structure and functions. Since it is technically difficult at present to introduce large repetitive DNA molecules into plant cells efficiently; minichromosomes, either those which occur naturally or those that are induced by irradiation, are another important alternative choice for determining minimum functional sizes of the centromeres and for constructing artificial chromosomes. Mammalian artificial minichromosomes also have several potential biotechnological and therapeutic applications arising from their ability to exist episomally, carry large DNA inserts, and allow expression of genes independently of the host genome.

### **Minichromosome in plants**

Minichromosomes technology is well known and successfully used in humans, fungi, yeast and other species as discussed above. In plant systems minichromosomes were discovered in the late nineties. Earlier the function and use of minichromosomes were not clearly known or reported in primary literature. Later it was discovered that minichromosomes are very useful to understand the basics of chromosomal structure and for the purpose of use in genetic engineering of plants. Recently, the Minichromosome technology offers enormous opportunities to improve crop plants.

### **Minichromosomes in *Arabidopsis***

The DNA structures of centromeres have been studied extensively in case of *Arabidopsis*, Since very small genomes (like that in *Arabidopsis*) has relatively small chromosomes; the DNA is estimated to be 17.5–29.1 Mb only; but it is still large to be easily manipulated *in vitro*. In teleocentric line of *A. thaliana*, a

minichromosome was identified through Fluorescence *In Situ* Hybridization (FISH) approach and it revealed that it was from the short arm of chromosome number 4. The size of this “mini4S” chromosome was estimated to be ~7.5 Mb on the basis of previously reported data and the amount of the centromeric major satellite (180-bp family) present, which was determined to be about 1 Mb, or about one third of that in the normal chromosome 4. The researchers also reported the size, centromeric function and the meiotic behavior of minichromosome. Recently, two more minichromosome ( $\alpha$ ,  $\beta$  and  $\delta$ ) have also been discovered by the same research group. These two minichromosomes were found in a transgenic *Arabidopsis* plant produced by *in planta* vacuum infiltration technique.

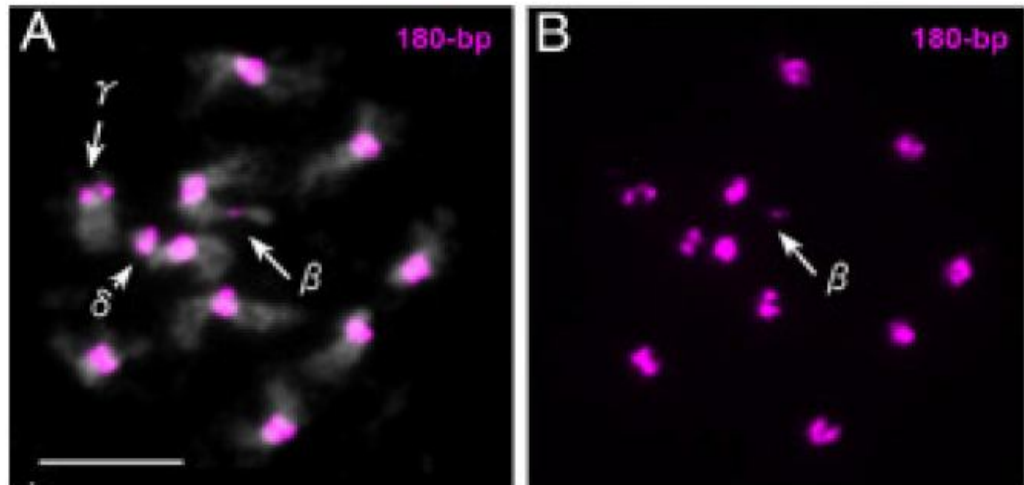
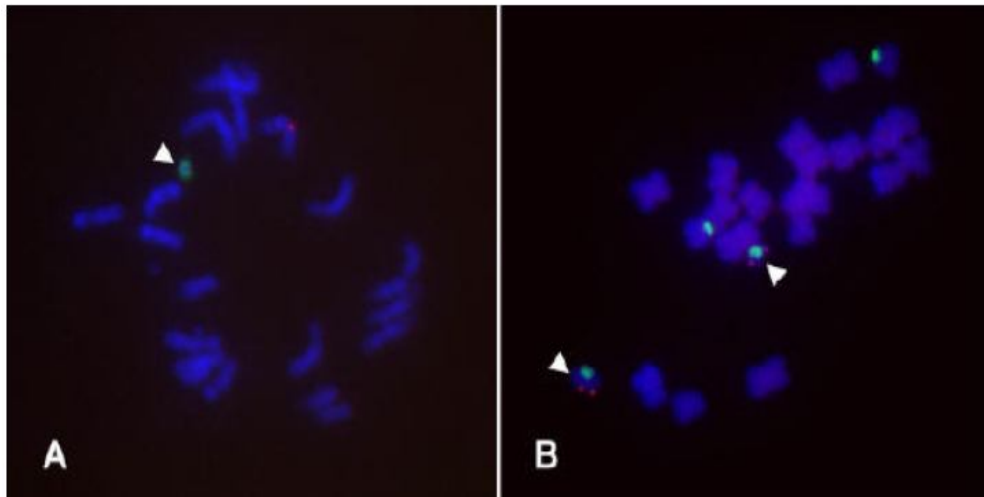

**Figure- 7: Cytological analysis of a G40 *Arabidopsis* cell containing minichromosomes  $\alpha$ ,  $\beta$  and  $\delta$ .**

#### **Minichromosome in maize**

The maize B chromosome exists in only some varieties of maize. The properties and function of B chromosomes in maize were discovered by Carlson and Roseman (1992) and rediscovered by Ronceret et al., in 2007 in the light of minichromosomes. Recently, maize minichromosomes were engineered by modifying A and B chromosome using telomere-mediated chromosome truncation. These minichromosomes were transferred to a diploid background by repeated backcrossing and were stably maintained. By using the same set of constructs, they targeted the maize B chromosome with biolistic-mediated gene transformation. Truncated B chromosomes were recovered with much greater

efficiency. The sizes of the mini B chromosomes ranged from very small to almost the full size of the normal B chromosome. Although they produced A and B minichromosomes by this method but they were more interested in B chromosome based minichromosomes, because B chromosomes has many interesting properties (Kato et al., 2005), such as: (i) the truncation of B chromosomes will not cause developmental or transmission problems as A chromosomes do; (ii) the B chromosome derivatives can be distinguished by their shape and the presence of a B chromosome specific repeat in and around the centromeric region; and (iii) the size of mini B chromosomes is not crucial because there will be no residual endogenous genes that might interfere with plant development and transgene expression. Recently, Carlson et al., (2007) developed maize minichromosomes (MMCs) and demonstrated that autonomous MMCs can be mitotically and meiotically maintained.



**Figure- 8: Minichromosomes produced from maize B chromosome truncation, arrows denote minichromosomes**

#### **Future prospects of minichromosomes**

Engineered minichromosomes can be used in all areas of future genetic engineering. Minichromosomes can be used in site-specific recombination or retrofitting the minichromosomes with additional foreign genes (Ow 2007). Minichromosomes can also be used for gene stacking in plants, which is currently considered as challenging for plant biotechnology (Halpin 2005). Minichromosomes can also facilitate an understanding of fundamental questions about chromosomal structure and function, such as for centromeres, neocentromeres, B chromosome non-disjunction as well as chromosomal behavior in general., In addition, it might be possible to develop a mini B

chromosome-based genomic cloning system for capturing large chromosome fragments. The B

chromosomes in maize can accumulate up to many copies. Because mini-B chromosomes can non-disjoin in the presence of normal B chromosomes, it may be possible to accumulate higher numbers of mini B chromosomes than normal B chromosomes.

Recently a private company called CHROMATIN<sup>®</sup> (for details please refer [www.chromatininc.com](http://www.chromatininc.com)).got three patents from “United States Patent and Trademark Office” for their minichromosome technology (<http://patft.uspto.gov/>; U.S. Patent Nos. 7,227,057 and 7,226,782 and 7,193,128). The Chromatin<sup>®</sup> technology uses a single heritable piece of the plant’s own DNA to generate a minichromosome. The issued patents describe minichromosome DNA sequences and the use of those sequences to incorporate genes to the plants. Chromatin<sup>®</sup> Inc. develops and markets novel proprietary technology that enables entire chromosomes to be designed and incorporated into plant cells. These minichromosomes can be used in any plant or crop to simultaneously introduce multiple genes while maintaining precise control of gene expression. Chromatin’s minichromosome technology can be used to deliver genes that benefit the agricultural, nutritional, energy, pharmaceutical, and chemical sectors.

---

## 1.6 Giant Chromosomes

---

**Giant chromosomes:** The chromosomes which are extremely large compared to normal chromosomes. Such chromosomes, called giant chromosomes occur in some animal cells.

Two types of giant chromosomes are known:

1. Lampbrush Chromosome
2. Polytene Chromosome

**1. Lampbrush Chromosome:** These chromosomes occur in the oocytes (germcells in the ovary) of amphibians and in some insects. They are extremely large synapsed homologous chromosomes which can be seen in the diplotene stage of prophase-I in meiosis. They measure about 1500 to 2000 $\mu$ m in length. A lampbrush chromosome consists of an axis from which paired loops extend in opposite directions, giving the appearance of a lamp brush. The axis consists of chromomeres (nucleosomes) and interchromomere regions. The loops consist of transcriptionally active DNA



which can synthesize large amount of mRNA, necessary for the synthesis of yolk.

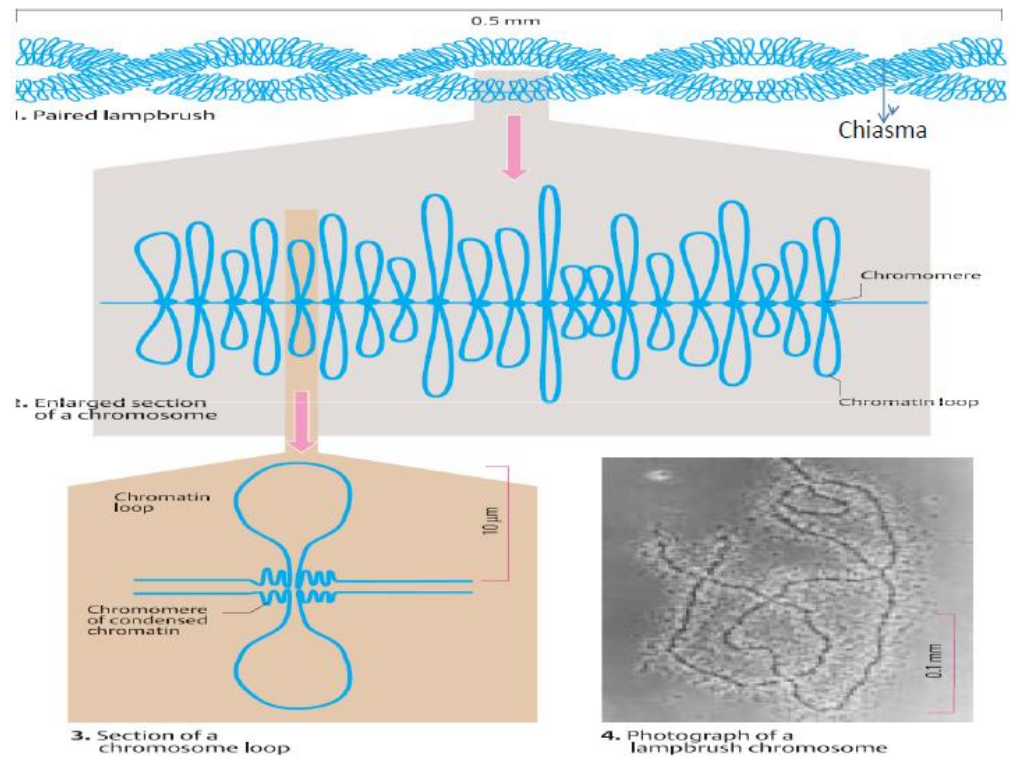

**Figure- 8: Lampbrush chromosome structure in amphibian oocytes**

2. **Polytene Chromosomes:** These are giant chromosomes found in the salivary gland cells of the fruit fly *Drosophila*. They are many times larger than the normal chromosomes reaching a length of 2000  $\mu\text{m}$  and are visible even under a compound microscope. The polytene chromosomes appear to contain five long and one short arm radiating from a central point called chromocentre. It is formed by the fusion of centromeres of all the eight chromosomes found in the cell. Of the 6 arms, the short arm represents the fused IV chromosome and the longest represents the fused sex chromosomes. These arms contain numerous chromonemata resulting from repeated replication of DNA, without separation into daughter chromosomes. The arms show characteristic dark bands and light bands. The dark bands are euchromatic regions. Some of the dark bands temporarily swell up and form enlargements called chromosomal puffs or Balbiani rings. These regions contain actively transcribing DNA involved in the synthesis of RNA types.

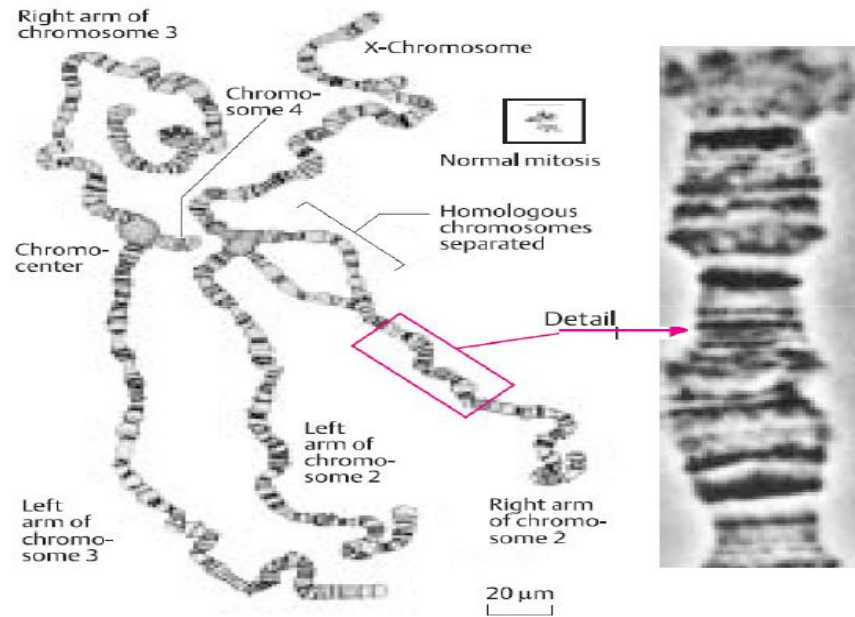

**Figure- 9: Polytene chromosomes in the salivary gland cells of the fruit fly *Drosophila***

---

## 10.7 Glossary

---

- **Gene expression:** Synthesis of RNA, and often protein, directed by the nucleotide sequence in a specific segment of DNA (Gene).
- **Transcription:** The process of RNA synthesis that is catalyzed by RNA polymerase; It uses a DNA strand as a template.
- **Translation:** The process of protein synthesis in which the amino acid sequence of a protein is determined by mRNA mediated by tRNA molecules and carried out on ribosome.
- **FISH:** Fluorescence *in situ* hybridization (FISH) is a laboratory technique for detecting and locating a specific DNA sequence on a chromosome.
- **M-FISH:** A technique for visualizing the 22 human autosomal chromosomes and the 2 sex chromosomes, in different colors, which readily identify the euchromatin in marker chromosomes.
- **GISH:** It refers to an *in situ* hybridization technique that uses total genomic DNA of a given species as a probe and total genomic DNA of another species as a blocking DNA.

- **Giant chromosome:** There are chromosomes which are extremely large compared to normal chromosomes. Such chromosomes, called giant chromosomes occur in some animal cells.
- **Mini chromosomes:** A minichromosome is a small chromatin-like structure consisting of centromeres, telomeres and replication origins.

---

## 9.8 Self-Learning Exercise

---

### Section -A (Very Short Answer Type):

1. Introns are portions of the \_\_\_\_\_ that do not code for \_\_\_\_\_
2. Gene expression is \_\_\_\_\_
3. Define Exons.
4. FISH extend for \_\_\_\_\_
5. GISH extend for \_\_\_\_\_

### Section -B (Short Answer Type):

1. What is gene expression?
2. What is Transcription?
3. A Short note on Translation?
4. Explain giant chromosomes.
5. What is Enhancers?
6. A Short note on minichromosomes.
7. Differentiate polytene and lampbrush chromosomes?.
8. What is M-FISH?

### Section -C (Long Answer Type)

1. Explain the process of gene expression?
2. Write about FISH and M-FISH?
3. Describe the genomic *in situ* hybridization?
4. Briefly describe the minichromosomes?

---

## 9.9 References

---

- Molecular Cell Biology by Harvey Lodish

- Molecular Systematics and Plant Evolution by Peter M. Hollingsworth, Richard M. Bateman, Richard J. Gornall
- Culture of Animal Cells: A Manual of Basic Technique and Specialized Applications by R. Ian Freshney
- Genetics by Karvita B. Ahluwalia
- Cell and Molecular Biology by Gerald Karp
- Genes: VII by Benjamin Lewin

## Unit-10

---

# Cell cycle, Mitosis and Meiosis

---

### Structure of the Unit

- 10.0 Objective
- 10.1 Introduction
- 10.2 Stages of Cell cycle
- 10.3 Centriole Cycle
- 10.4 Types of Cell division
- 10.5 Mitosis
  - 10.5.1 Stages of Mitosis
  - 10.5.2 Significance of Mitosis
- 10.6 Miosis
  - 10.6.1 Stages of Meiosis
  - 10.6.2 Significance of Meiosis
- 10.7 Summery
- 10.8 Glossary
- 10.9 Self-Learning Exercise
- 10.10 References

---

### 10.0 Objective

---

After going through this unit you will be able to understand:

- What is cell cycle
- Stages of Cell cycle
- Centriole Cycle
- Difference between Meiosis and Mitosis
- Significance of Cell division

---

### 10.1 Introduction

---

According to cell theory proposed by Schledien and Schwann cell is the structural unit of life, all organisms are composed of one or more cells. New

cells originate only from other living cells. Cell division is an inherent property of living organisms. It is a process in which cells reproduce their own kind. The growth, differentiation, reproduction and repair take place through cell division. Rudolf Virchow(1858) suggested “Omnis cellula e cellula” means every cell is derived from pre existing cell.

Cell Division:

Mother cells  $\longrightarrow$  Daughter cells (Cellular reproduction)

Cells are constantly being produced to replace old cells. ( $2.5 \times 10^6/s$ )

There are two types of cell division namely:

(a) Mitosis (b)Meiosis.

The cell capable of undergoing division passes through cell cycle.

Cells divide through certain defined stages. The stages through which a cell passes from one cell division to the next constitute a cell cycle.

---

## 10.2 Stages of Cell cycle

---

Cell cycle can be divided into two major phases based on cellular activities observable by light microscope:

- (a) Interphase: It has a nondividing, growing phase.
- (b) M Phase: It is a period during which cells divide.

**10.2.1 Interphase:** A period during which cells prepare for cell division. Time duration long and may vary depending on conditions. It is a long, metabolically active phase between two successive mitotic cell division. In this phase macromolecules(DNA, protein etc) are synthesized. Defined and regulated biochemical activities are found during interphase. The overall rate of RNA and protein synthesis is relatively constant through interphase.

It has four sub stages namely:

- (ii) Gap 0 (G0): There are times when a cell will leave the cycle and quit dividing. This may be a temporary resting period or more permanent. An example of the latter is a cell that has reached an end stage of development and will no longer divide (e.g. neuron).
- (iii) Gap 1 (G1) phase (post mitotic phase): During this phase metabolic changes prepare the cell for division. At a certain point called as restriction point, the cell is committed to division and

moves into the S phase. The cell prepares for DNA, RNA and protein synthesis.

- (iv) S phase (synthetic phase): in this phase DNA synthesis replicates the genetic material. Each chromosome now consists of two sister chromatids. The duplication or Replication of DNA and centriole take place.
- (v) Gap 2 (G<sub>2</sub>) phase (post mitotic phase): Metabolic changes assemble the cytoplasmic materials necessary for mitosis and cytokinesis. The synthesis of proteins required for the synthesis of spindle fibres take place in this phase of cell cycle.

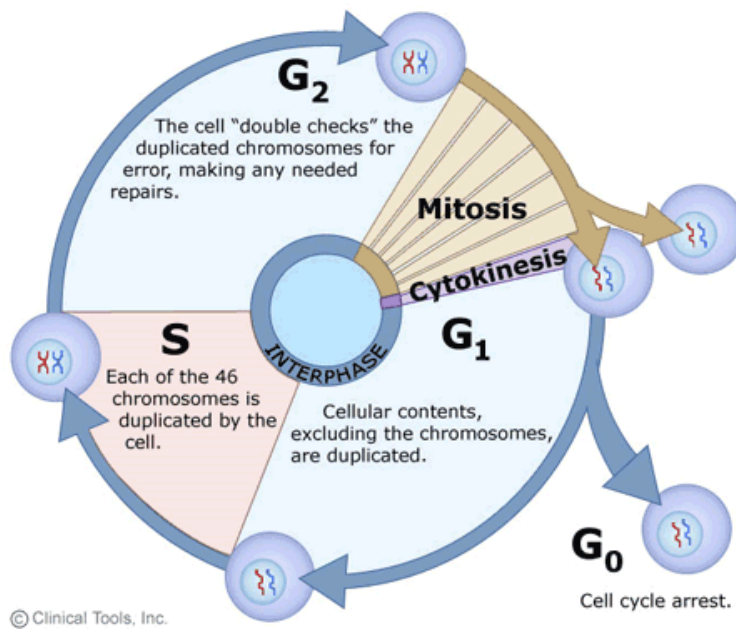

**Fig.1 Stages in Interphase**

### 10.2.2 M phase

The M phase includes a nuclear division (mitosis) followed by a cell division (cytokinesis). This is the most dramatic period of the cell cycle, involving a major reorganisation of virtually all components of the cell. Since the number of chromosomes in the parent and progeny cells is the same, it is also called as equational division. Mitosis is a process during which duplicated chromosomes are separated into two nuclei while cytokinesis is the stage during which the entire cell divides into two daughter cells. M phase is a short duration phase of around 30 – 60 minutes, Synthesis of macromolecules is largely shut down and active synthesis of macromolecules (DNA, protein etc) takes place during this

phase. Though for convenience mitosis has been divided into four stages of nuclear division, it is very essential to understand that cell division is a progressive process and very clear-cut lines cannot be drawn between various stages.

At the molecular level M phase is initiated by a cascade of protein phosphorylations triggered by the activation of the mitosis-inducing protein kinase MPF, and it is terminated by the dephosphorylations that follow the inactivation of MPF through proteolysis of its cyclin subunits. The protein phosphorylations that occur during M phase are responsible for the many morphological changes that accompany mitosis: the chromosomes condense, the nuclear envelope breaks down, the endoplasmic reticulum and Golgi apparatus fragment, the cell loosens its adhesions to other cells and the extracellular matrix, and the cytoskeleton is transformed to bring about the highly organized movements that will segregate the chromosomes and partition the cell. Because M phase involves a complete reorganization of the cell interior, the number of proteins that become phosphorylated is thought to be large, and essentially every part of the cell is affected in some way.

Three Features Are Unique to M Phase: Chromosome Condensation, the Mitotic Spindle, and the Contractile Ring. The nuclear division is mediated by a microtubule based mitotic spindle, which separates the chromosomes, while the cytoplasmic division is mediated by an actin-filament-based contractile ring. Mitosis is largely organized by the microtubule asters that form around each of the two centrosomes produced when the centrosome duplicates. Centrosome duplication begins during the S and G<sub>2</sub> phases of the cell cycle, and the duplicated centrosomes separate and move to opposite sides of the nucleus at the onset of M phase to form the two poles of the mitotic spindle. Large membrane-bounded organelles, such as the Golgi apparatus and the endoplasmic reticulum, break up into many smaller fragments during M phase, which ensures their even distribution into daughter cells during cytokinesis.

---

### **10.3 Centriole Cycle**

---

The process of centrosome duplication and separation is known as the centrosome cycle. During interphase of each cell cycle, the centrioles and other components of the centrosome are duplicated but remain together as a single complex on one side of the nucleus. As mitosis begins, this complex splits in two and each centriole pair becomes part of a separate microtubule organizing center that nucleates a radial array of microtubules called an aster. The two asters move to opposite sides of the nucleus to form the two poles of the mitotic



spindle. As mitosis ends and the nuclear envelope re-forms around the separated chromosomes, each daughter cell receives a centrosome (the former spindle pole) in association with its chromosomes.

The centrosome in an interphase cell duplicates to form the two poles of a mitotic spindle. In most animal cells a centriole pair is associated with the centrosome matrix that nucleates microtubule outgrowth. Centriole duplication begins in G<sub>1</sub> and is completed by G<sub>2</sub>. Initially, the two centriole pairs and associated centrosome matrix remain together as a single complex. In early M phase this complex separates into two and each centrosome nucleates a radial array of microtubules, called an aster. The two asters, which initially lie side by side and close to the nuclear envelope, move apart. By late prophase the bundles of polar microtubules that interact between the two asters preferentially elongate as the two centers move apart along the outside of the nucleus. In this way a mitotic spindle is rapidly formed. At metaphase the nuclear envelope breaks down, enabling the spindle microtubules to interact with the chromosomes; at cytokinesis the nuclear envelope reforms around the two sets of segregated chromosomes, excluding the centrosomes.

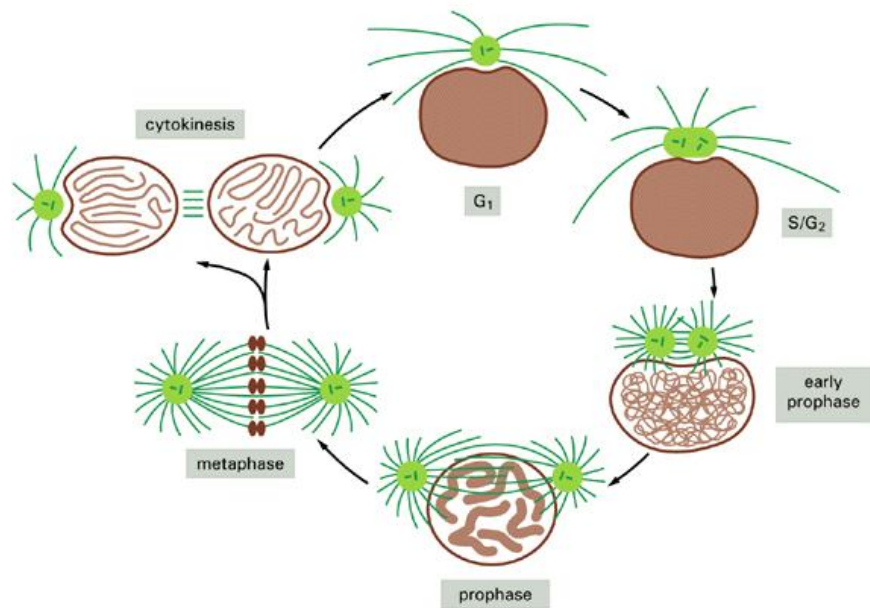

**Figure 2: The centriole cycle of an animal cell**

---

### 10.3 Types of Cell division

---

The cell division is divided into two types; Meiosis and Mitosis and on the bases of dividing potential cells can be divided in into three types:

1. Cells that never divide: Nerve cells, muscle cells and red blood cells lost the ability to divide once it differentiated until its death.
2. Cells that normally do not divide but can be induced to divide: Liver cells can be induced to divide once surgically remove part of it. Lymphocytes can be induced to divide by antigens.
3. Cells that normally possess high level of mitotic activity: Spermatogonia, hematopoietic stem cells, epithelia cells.

Cytoplasm of the cell contain various regulatory factors which affect cell cycle activities and controls cell cycle. This tight control prevents imbalanced, excessive growth of tissues while assuring that worn-out or damaged cells are replaced and that additional cells are formed in response to new circumstances or developmental needs. For instance, the proliferation of red blood cells increases substantially when a person ascends to a higher altitude and needs more capacity to capture oxygen. Some highly specialized cells in adult animals, such as nerve cells and striated muscle cells, rarely divide, if at all. The fundamental defect in cancer is loss of the ability to control the growth and division of cells.

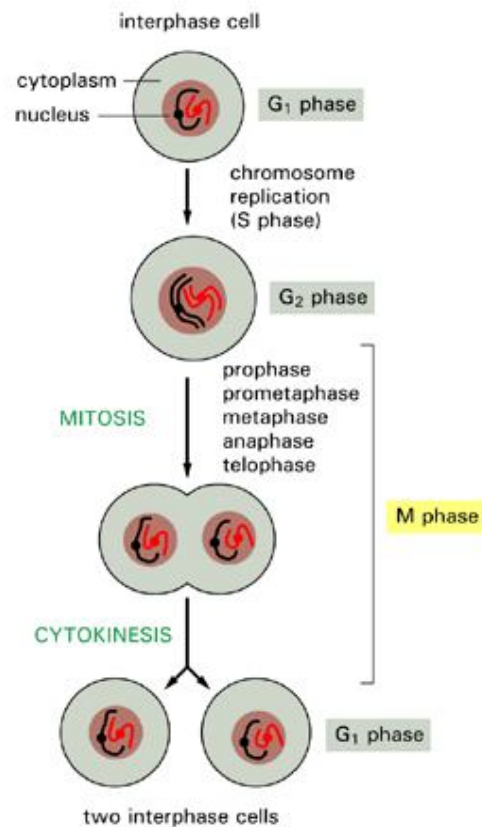

Figure3: The M phase of the cell cycle. M phase starts at the end of G2 phase and ends at the start of the next G1 phase. It includes the five stages of nuclear division (mitosis), as well as cytoplasmic division (cytokinesis).

---

## 10.4 Mitosis

---

Mitosis is an *asexual* process since the daughter cells carry the exact same genetic information as the parental cell. In *sexual* reproduction, fusion of two cells produces a third cell that contains genetic information from each parental cell. Since such fusions would cause an ever-increasing number of chromosomes, sexual reproductive cycles employ a special type of cell division, called meiosis, that reduces the number of chromosomes in preparation for fusion. Cells with a full set of chromosomes are called diploid cells. During meiosis, a diploid cell replicates its chromosomes as usual for mitosis but then divides twice without copying the chromosomes in-between. Each of the resulting four daughter cells, which has only half the full number of chromosomes, is said to be haploid. Sexual reproduction occurs in animals and plants, and even in unicellular organisms such as yeasts. Animals spend considerable time and energy generating eggs and sperm, the haploid cells, called gametes, that are used for sexual reproduction. A human female will produce about half a million eggs in a lifetime, all these cells form before she is born; a young human male, about 100 million sperm each day. Gametes are formed from diploid precursor germ-line cells, which in humans contain 46 chromosomes. In humans the X and Y chromosomes are called sex chromosomes because they determine whether an individual is male or female. In human diploid cells, the 44 remaining chromosomes, called autosomes, occur as pairs of 22 different kinds. Through meiosis, a man produces sperm that have 22 chromosomes plus either an X or a Y, and a woman produces ova (unfertilized eggs) with 22 chromosomes plus an X. Fusion of an egg and sperm (fertilization) yields a fertilized egg, the zygote, with 46 chromosomes, one pair of each of the 22 kinds and a pair of X's in females or an X and a Y in males (Figure 1-18). Errors during meiosis can lead to disorders resulting from an abnormal number of chromosomes. These include Down's syndrome, caused by an extra chromosome 21, and Klinefelter's syndrome, caused by an extra X chromosome.

Mitosis is a type of cell division in which a parental cell produces two similar daughter cells that resemble the parental cell in terms of chromosomal number. So it is also called Equational cell division (homotypic cell division). This

maintains constant number of chromosomes in each cell of successive generation. It occurs in somatic cells of the body. So, it is also called somatic cell division.

**10.5.1 Stages of mitosis:** Mitosis occurs in two stages viz., Karyokinesis and Cytokinesis.

A) Karyokinesis (Karyon – nucleus, kinesis – movement): It is the division of nuclear material. Mitosis consist of four phases:

- I. Prophase
- II. Metaphase
- III. Anaphase
- IV. Telophase

After telophase, the mother cell splits into two and produces two daughter cells by undergoing a process referred to as cytokinesis.

i. Prophase (Gr. Pro – before, phases – appearance): It is the first stage of mitosis follows the S and G<sub>2</sub> phases of interphase and it is the longest phase of mitosis. In the S and G<sub>2</sub> phases the new DNA molecules formed are not distinct but intertwined. Prophase is marked by the initiation of condensation of chromosomal material. The chromosomal material becomes untangled during the process of chromatin condensation. The centriole, which had undergone duplication during S phase of interphase, now begins to move towards opposite poles of the cell. The completion of prophase can thus be marked by the following characteristic events:

- (a) Chromosomal material condenses to form compact mitotic chromosomes. Chromosomes are seen to be composed of two chromatids attached together at the centromere.
- (b) Initiation of the assembly of mitotic spindle, the microtubules, the proteinaceous components of the cell cytoplasm help in the process.

### Mitosis, or somatic cell division

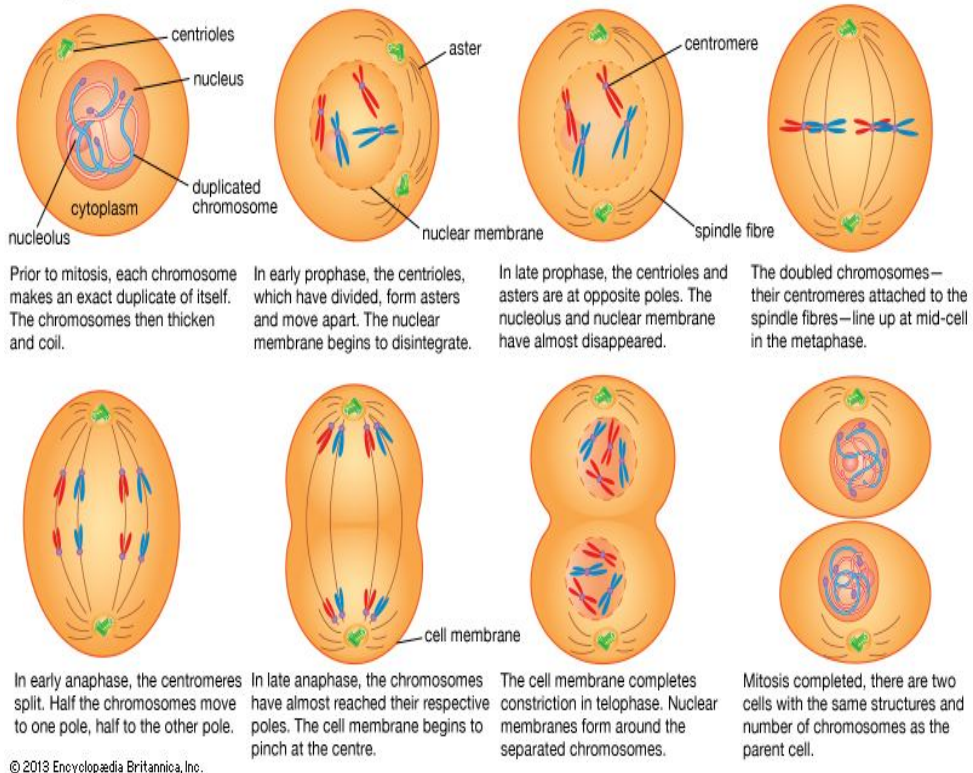

**Figure 4: Different stages of Mitosis.** Image source: <http://www.britannica.com/>

ii Metaphase (Meta – after, phase – appearance): The complete disintegration of the nuclear envelope marks the start of the second phase of mitosis, hence the chromosomes are spread through the cytoplasm of the cell. By this stage, condensation of chromosomes is completed and they can be observed clearly under the microscope. This then, is the stage at which morphology of chromosomes is most easily studied. At this stage, metaphase chromosome is made up of two sister chromatids, which are held together by the centromere. Small disc-shaped structures at the surface of the centromeres are called kinetochores. These structures serve as the sites of attachment of spindle fibres (formed by the spindle fibres) to the chromosomes that are moved into position at the centre of the cell. Hence, the metaphase is characterised by all the chromosomes coming to lie at the equator with one chromatid of each chromosome connected by its kinetochore to spindle fibres from one pole and its sister chromatid connected by its kinetochore to spindle fibres from the opposite pole. The plane of alignment of the chromosomes at metaphase is referred to as the metaphase plate. The key features of metaphase are:

- a. Spindle fibres attach to kinetochores of chromosomes.

b. Chromosomes are moved to spindle equator and get aligned along metaphase plate through spindle fibres to both poles.

iii) Anaphase (ana – up, phases - appearance): At the onset of anaphase, each chromosome arranged at the metaphase plate is split simultaneously and the two daughter chromatids, now referred to as chromosomes of the future daughter nuclei, begin their migration towards the two opposite poles. As each chromosome moves away from the equatorial plate, the centromere of each chromosome is towards the pole and hence at the leading edge, with the arms of the chromosome trailing behind. Thus, anaphase stage is characterised by the following key events:

a. Centromeres split and chromatids separate.

b. Chromatids move to opposite poles.

iv) Telophase (Telo – end, phases – appearance): At the beginning of the final stage of mitosis, the chromosomes that have reached their respective poles decondense and lose their individuality. The individual chromosomes can no longer be seen and chromatin material tends to collect in a mass in the two poles. This is the stage which shows the following key events:

a. Chromosomes cluster at opposite spindle poles and their identity is lost as discrete elements.

b. Nuclear envelope assembles around the chromosome clusters.

c. Nucleolus, golgi complex and ER reform

B) Cytokinesis (cyto – cell, kinesis – movement): It is the division of cytoplasm. A cleavage furrow develops in the middle of the cell in centripetal direction due to the contraction of microtubules. It occurs till the edges of the plasma membrane meet. They fuse to form a separate membrane. In plant cell, the cytokinesis occurs due to the formation of phragmoplast in centrifugal direction. The phragmoplast is formed by golgicomplex, ER and pectin containing vesicles.

**10.5.2 Significance of Mitosis:** It maintains genetic stability with in the population of cells derived from same parental cell, helps the growth and tissue repair, helps in the replacement of dead and worn out cells and this type of division is a means of reproduction in lower organisms.

---

## 10.6 Meiosis

---

The term meiosis was coined by Farmer and Moore (1905). It is a type of cell division in which the daughter cells receive only half of the original set of

chromosome of the parental cell. Hence it is also called reductional division. Meiosis is the mechanism by which eukaryotic cells produce mature sex cells or gametes. Meiosis produces four haploid cells (gametes), it involves partition of both cytoplasmic and nuclear structures. Meiosis occurs only in germinal cells found in male gonad (testis), female gonad (ovary) and in spore mother cells of plants. The reproductive cells have diploid (2n) number of chromosomes. They are a haploid paternal set and a haploid maternal set. But the reproductive cells have to undergo meiotic division to produce the gametes containing haploid (n) number of chromosomes. The haploid (n) male gamete (sperm) fertilizes with the haploid (n) female gamete (ovum) to produce a diploid (2n) zygote which develops into a individual having diploid number of chromosomes in each cell of the body. Thus meiosis helps to maintain the constant number of chromosomes for a particular species.

**10.6.1 Stages of Meiosis: Meiosis consists of Meiosis I and Meiosis II. They include the following stages:**

1	Interphase	3	Interkinesis
2	Meiosis I (reductional division)	4	Meiosis II (mitotic meiosis)
A	Karyokinesis I i) Prophase I a) Leptotene b) Zygotene c) Pachytene d) Diplotene e) Diakinesis ii) Metaphase I iii) Anaphase I iv) Telophase I	A	KaryokinesisII i) Prophase II ii) Metaphase II iii) Anaphase II iv) Telophase II
B	Cytokinesis I	B	Cytokinesis II

1. Interphase I: During interphase the duplication of DNA, centrioles and synthesis of RNA and proteins take place.

2. Meiosis I: It is reductional division in which a diploid parental cell produces two haploid daughter cells. Hence it is called reductional division. It includes following stages.
- A) Karyokinesis I: It is the division of nucleus that takes place in the following stages.
- i) Prophase I: It is the longest phase of meiosis. It has 5 sub stages.
- a) Leptotene: It can also be called as bouquet stage. The chromatin condenses to form chromosomes, the chromosomes appear as long, thin and thread like structures. They undergo coiling and become short and thick. Each chromosome has two chromatids that are not distinctly visible, each chromosome shows bead like structures called chromomeres. The telomeric ends of all the chromosomes converge towards one side of nuclear membrane hence they appear horse shoe shaped. This stage is called Bouquet stage.
- b) Zygotene (Zipper stage): During this stage pairing of homologous chromosomes takes place called synapsis and the pair is called bivalent. The chromosome continues to undergo condensation and asters keep moving towards opposite poles. Centrioles form into asters and keep moving towards opposite poles.
- c) Pachytene (Tetrad stage): In this stage the chromosomes become more short and thick. Each bivalent shows four chromatids called tetrad. In this stage the exchange of genetic material takes place between the non sister chromatids of homologous chromosomes. This process is called genetic crossing over (The region at which the crossing over occurs is called as chiasmata). This results in genetic recombination which is responsible for variations.
- d) Diplotene: In this stage the chiasma move towards the tips of chromosomes as the homologous chromosomes of bivalent start moving apart. This event is called as terminalisation.
- e) Diakinesis: The chromosomes at this stage appear thick, short and distinct. The tips of some chromosome show chiasma. Nucleolus and Nuclear membrane disappear and chromosomes set become free in the cytoplasm.



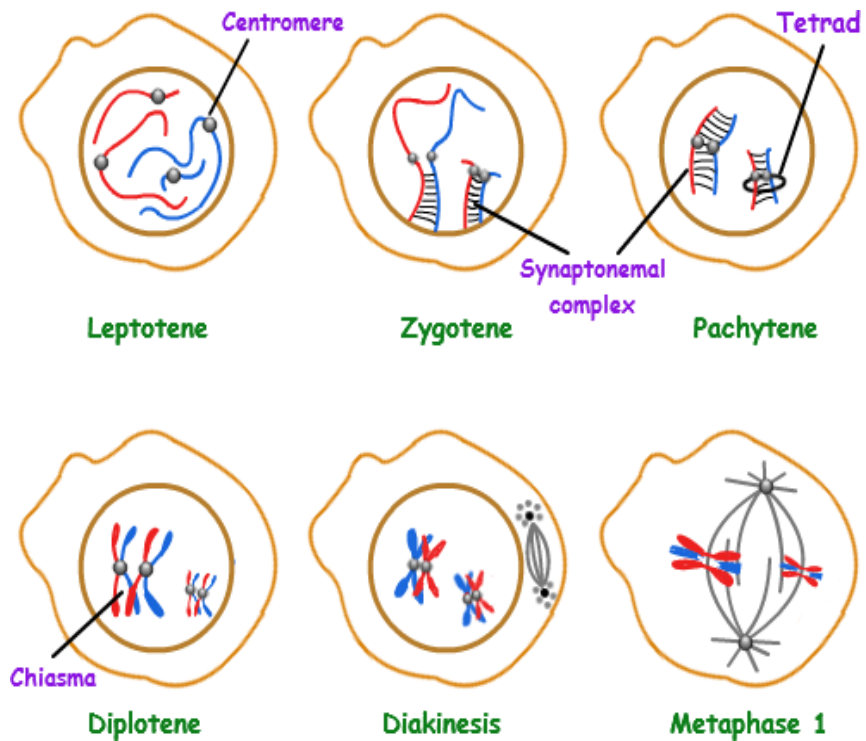
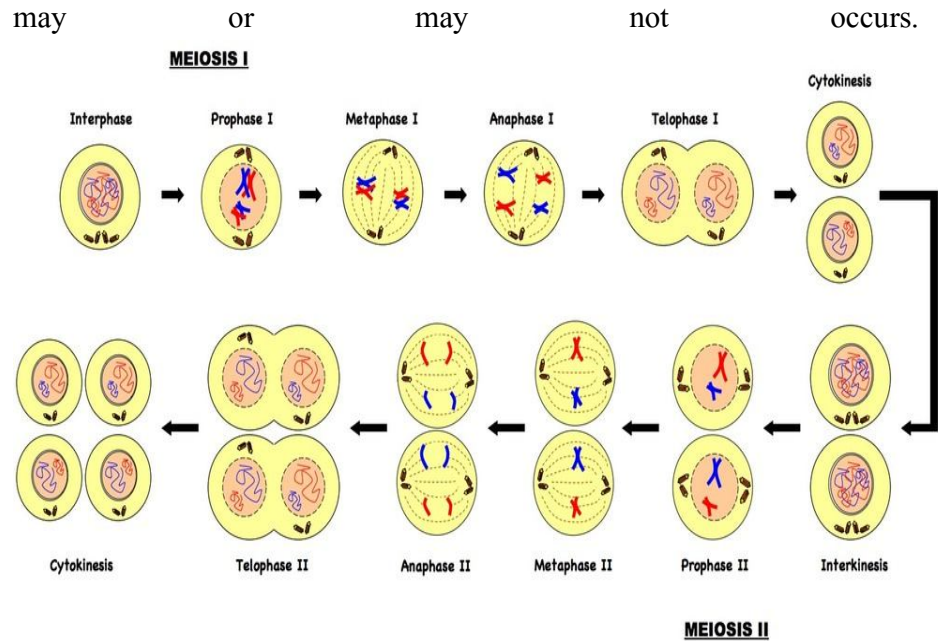

Figure5: Stages of KaryokinesisI of MeiosisI

Image source <http://biology.tutorvista.com/>

- ii) **Metaphase-I:-** In this stage chromosomes are arranged in the equatorial region with their centromeres towards the poles and arms towards the equator.
- iii) **Anaphase-I:-** The Centromeres do not under go longitudinal splitting. The chromosome of each homologous pair move towards opposite poles by the activity of spindle fibres. This is called separation or disjunction of chromosomes.
- iv) **Telophase-I:-**The homologous chromosomes separate and reach the opposite poles. The nuclear membrane reappears around the chromosomes at each pole and the spindle fibres disappear, cytokinesis



**Figure6: Stages of Meiosis** *Mage source:*<http://www.ib.bioninja.com.au/>

B) Cytokinesis I (cyto – cell, kinesis – movement): It is the division of cytoplasm. A cleavage furrow develops in the middle of the cell in centripetal direction due to contraction of microtubules. It occurs till the edges of the plasma membrane meet. They fuse to form separate membrane. It may or may not occur at the end of meiosis I.

3. **Interkinesis:** The Interphase after the first meiotic division is called Interkinesis. It may be present or absent between meiosis-I and meiosis-II. If present it may be short or in some cases telophase-I directly enters to prophase-II. It is similar to Interphase except for the absence of replication of DNA.

4. **Meiosis-II:** it occurs soon after meiosis-I. There is no duplication of chromosomes in this stage. Events recognized under four stages for convenience are:-Prophase-II, Metaphase-II, Anaphase-II, andTelophase-II.

A) **Karyokinesis II:** It is the division of nucleus. It includes

i) **Prophase-II:-** The chromosomes start condensing again, spindle apparatus begin to appear and thenuclear envelope and nucleolus disintegrate and disappear

ii) **Metaphase-II:-**The Chromosomes arrange in the equatorial region at right angles to the asters and the Spindle fibres connect to the centromere.

**iii) Anaphase-II:-** The centromeres of all the chromosomes undergo longitudinal splitting and the chromatids of each chromosome separate and they move towards opposite poles

**iv) Telophase-II:-** The chromosomes arrive at the poles and undergo decondensation to become thin and long chromatin fibres. A nuclear envelope is formed, nucleolus also appears and the spindle fibres disappear.

**(C) Cytokinesis II (cyto – cell, kinesis – movement):** It is the division of cytoplasm. A cleavage furrow develops in the middle of the cell in centripetal direction due to contraction of microtubules. It occurs till the edges of the plasma membrane meet. They fuse to form separate membrane.

#### **10.6.2 Significance of meiosis**

Meiosis is the mechanism by which conservation of specific chromosome number of each species is achieved across generations in sexually reproducing organisms, even though the process, per se, paradoxically, results in reduction of chromosome number by half. It also increases the genetic variability in the population of organisms from one generation to the next. Variations are very important for the process of evolution.

---

### **10.7 Summary**

---

According to the cell theory, cells arise from preexisting cells. The process by which this occurs is called cell division. Any sexually reproducing organism starts its life cycle from a single-celled zygote. Cell division does not stop with the formation of the mature organism but continues throughout its life cycle. The cell cycle is the sequence of events or changes that occur between the formation of cell and its division into daughter cells. It has a nondividing, growing phase called Interphase and dividing phase called mitotic or M-phase. The Interphase is a preparatory phase having three sub stages namely G<sub>1</sub>, S and G<sub>2</sub> phase. During Interphase replication of DNA and protein synthesis occurs as a preparation for cell division. Mitosis includes Karyokinesis and Cytokinesis. Karyokinesis is the division of the nucleus that occurs in four stages. They are prophase, metaphase, anaphase and Telophase. During prophase, the chromatin condenses to form chromosomes. centrioles develop into asters and move towards the opposite poles. Nucleolus and nuclear membrane disappears. During metaphase the chromosomes arrange along the equatorial plane and the formation of spindle fibres takes place. During anaphase the centromere of all the chromosomes splits and the daughter chromosomes move towards the asters by the activity of spindle fibres. During

Telophase, the daughter chromosomes reach the poles and undergo uncoiling to form chromatin threads. The nuclear membrane and nucleolus reappears and the spindle fibres disappear. This is followed by the division of cytoplasm resulting in two daughter cells having same number of chromosomes as that of the parental cells. So mitotic division is also called equational division. The mitosis helps in growth, tissue repair and replacement of dead and worn-out cells and in reproduction.

In contrast to mitosis, meiosis occurs in the diploid cells, which are destined to form gametes. It is called the reduction division since it reduces the chromosome number by half while making the gametes. In sexual reproduction when the two gametes fuse the chromosome number is restored to the value in the parent. Meiosis is divided into two phases – meiosis I and meiosis II. In the first meiotic division the homologous chromosomes pair to form bivalents, and undergo crossing over. Meiosis I has a long prophase, which is divided further into five phases. These are leptotene, zygotene, pachytene, diplotene and diakinesis. During metaphase I the bivalents arrange on the equatorial plate. This is followed by anaphase I in which homologous chromosomes move to the opposite poles with both their chromatids. Each pole receives half the chromosome number of the parent cell. In telophase I, the nuclear membrane and nucleolus reappear. Meiosis II is similar to mitosis. During anaphase II the sister chromatids separate. Thus at the end of meiosis four haploid cells are formed. Meiosis helps to restore diploid number of chromosomes in a species. It also brings about genetic recombinations that result in speciation.

---

## 10.8 Glossary

---

- **Interphase:** A period during which cells prepare for cell division.
- **M Phase:** The M phase includes a nuclear division (mitosis) followed by a cell division (cytokinesis).

---

## 10.9 Self-Learning Exercise

---

### Section -A (Very Short Answer Type)

1. Cell division can not be stopped in which phase of the cell cycle?
2. The non-sister chromatids twist around and exchange segments with each other during.....
3. Synapsis occurs between.....
4. Name the stages of Meiosis in Karyokinesis I
5. Who suggested every cell is derived from pre existing cell.
6. MPF is .....

### **Section -B (Short Answer Type)**

1. Define kariyokinesis
2. Write distinguishing features of metaphase of Mitosis
3. Differentiate between prophase I and Prophase II of Meiosis?
4. What is synapsis and crossing over?
5. What do you know about telophase in mitosis?

### **Section -C (Long Answer Type)**

1. Write a note on Cell cycle.
2. Explain various stages of Meiosis.
3. Explain various stages of Mitosis.
4. What do you understand with centiole cycle?

### **Answer Key of Section-A**

1. S-Phase
2. Pachytene
3. homologous chromosomes
4. i) Prophase I, a) Leptotene, b) Zygotene, c) Pachytene, d) Diplotene, e) Diakinesis, ii) Metaphase I, iii) Anaphase I, Telophase I
5. Rudolf Virchow(1858) suggested "Omnis cellula e cellula" means every cell is derived from pre existing cell.
6. mitosis-inducing protein kinase.

---

## **10.10 References**

---

- Molecular Biology of Cell, Alberts B et al. Garland Publishers, (2001)
- Molecular Cell Biology, Lodish et al. Scientific American Books (1995)
- Cell and Molecular Biology, Karp G, John Wiley and Sons. (1999).
- Cell Biology, C.B. Panwar

# Unit - 11

---

## **Biotechnology basics: Genetic engineering, culture media, culture methods, restriction enzymes, cloning vectors, somatic hybridization**

---

### **Structure of the Unit**

- 11.0 Objectives
- 11.1 What is Biotechnology?
- 11.2 What is genetic engineering?
  - 11.2.1 Laying the foundations
  - 11.2.2 First steps
- 11.3 Concept of culture
  - 11.3.1 Media
  - 11.3.2 Common constituents of culture media
  - 11.3.3 Types of media
- 11.4 Culture Methods
  - 11.4.1 Streak plate method
  - 11.4.2 Pour plate method
  - 11.4.3 Spread plate method
  - 11.4.4 Roll tube method:
- 11.5 Restriction enzymes (restriction endonucleases)
  - 11.5.1 Type II restriction endonucleases
  - 11.5.2 Nomenclature
  - 11.5.3 Blunt ends and sticky ends
  - 11.5.4 The frequency of recognition sequences in a DNA molecule
- 11.6 Cloning vectors
  - 11.6.1 Plasmids as vectors

- 11.6.1.1 Size and copy number
- 11.6.1.2 Conjugation and compatibility
- 11.6.1.3 Plasmid classification
- 11.6.1.4 Plasmids in organisms other than bacteria
- 11.6.1.5 Cloning vectors based on E. coli plasmids
- 11.6.1.6 The nomenclature of plasmid cloning vectors
- 11.6.1.7 Features of pBR322
- 11.6.2 Phage as vectors
  - 11.6.2.1 The phage infection cycle
  - 11.6.2.2 Insertion and replacement vectors
  - 11.6.2.3 M13—a filamentous phage
- 11.6.3 Cosmids
- 11.6.4 Phagemids (Hybrid plasmid–M13 vectors)
- 11.6.5 BAC
- 11.6.6 YAC
- 11.6.7 PACs
- 11.6.8 Expression vectors
- 11.6.9 Shuttle vectors
- 11.6.10 Vectors for cloning in higher plants
  - 11.6.10.1 Ti Plasmids
  - 11.6.10.2 Ri Plasmids
- 11.6.11 Vectors for animal cells
  - 11.6.11.1 Viruses as cloning vector
- 11.7 Somatic Hybridization
- 11.8 Summary
- 11.9 Self-Learning Exercise
- 11.10 References

---

## 11.0 Objectives

---

After going through this unit you will be able to understand

- About biotechnology
- What is genetic engineering?
- Culture media.
- Culture methods.
- Restriction enzymes.
- Vectors.
- Variety of vectors.
- Somatic Hybridization.

---

## **11.1 What is Biotechnology?**

---

Biotechnology is the use of living systems and organisms to develop or make useful products, or "any technological application that uses biological systems, living organisms or derivatives thereof, to make or modify products or processes for specific use". At its simplest, biotechnology is technology based on biology - biotechnology harnesses cellular and biomolecular processes to develop technologies and products that help improve our lives and the health of our planet. The term itself is largely believed to have been coined in 1919 by Hungarian engineer Károly Ereky.

We have used the biological processes of microorganisms for more than 6,000 years to make useful food products, such as bread and cheese, and to preserve dairy products. Humankind has used biotechnology, for thousands of years, in agriculture, food production, and medicine. In the late 20th and early 21st century, biotechnology has expanded to include new and diverse sciences such as genomics, recombinant gene technologies, applied immunology, and development of pharmaceutical therapies and diagnostic tests.

Modern biotechnology provides breakthrough products and technologies to combat debilitating and rare diseases, reduce our environmental footprint, feed the hungry, use less and cleaner energy, and have safer, cleaner and more efficient industrial manufacturing processes.

The science of biotechnology can be broken down into subdisciplines called red, white, green, and blue. Red biotechnology involves medical processes such as getting organisms to produce new drugs, or using stem cells to regenerate damaged human tissues and perhaps re-grow entire organs. White (also called gray) biotechnology involves industrial processes such as the production of new chemicals or the development of new fuels for vehicles. Green biotechnology



applies to agriculture and involves such processes as the development of pest-resistant grains or the accelerated evolution of disease-resistant animals. Blue biotechnology, rarely mentioned, encompasses processes in marine and aquatic environments, such as controlling the proliferation of noxious water-borne organisms.

Biotechnology, like other advanced technologies, has the potential for misuse. Concern about this has led to efforts by some groups to enact legislation restricting or banning certain processes or programs, such as human cloning and embryonic stem-cell research. There is also concern that if biotechnological processes are used by groups with nefarious intent, the end result could be biological warfare.

<b>Traditional Biotechnology</b>	<b>Modern Biotechnology</b>
Brewing	Cell and tissue culture Plant tissue culture Animal cell culture
Food fermentation	Genetic engineering/Molecular biotechnology Recombinant DNA technology
Conventional vaccine production	Monoclonal antibodies Use of diagnostic tools to detect proteins

---

## **11.2 What is genetic engineering?**

---

Progress in any scientific discipline is dependent on the availability of techniques and methods that extend the range and sophistication of experiments that may be performed. Over the past 35 years or so this has been demonstrated in a spectacular way by the emergence of genetic engineering. This field has grown rapidly to the point where, in many laboratories around the world, it is now routine practice to isolate a specific DNA fragment from the genome of an organism, determine its base sequence, and assess its function. The technology is also now used in many other applications, including forensic analysis of

scene-of-crime samples, paternity disputes, medical diagnosis, genome mapping and sequencing, and the biotechnology industry. What is particularly striking about the technology of gene manipulation is that it is readily accessible by individual scientists, without the need for large-scale equipment or resources outside the scope of a reasonably well-funded research laboratory. Although the technology has become much more large-scale in recent years as genome sequencing projects have been established, it is still accessible by almost all of the bioscience community in some form or other.

The term genetic engineering is often thought to be rather emotive or even trivial, yet it is probably the label that most people would recognize. However, there are several other terms that can be used to describe the technology, including gene manipulation, gene cloning, recombinant DNA technology, genetic modification, and the new genetics. There are also legal definitions used in administering regulatory mechanisms in countries where genetic engineering is practiced.

Although there are many diverse and complex techniques involved, the basic principles of genetic manipulation are reasonably simple. The premise on which the technology is based is that genetic information, encoded by DNA and arranged in the form of genes, is a resource that can be manipulated in various ways to achieve certain goals in both pure and applied science and medicine. There are many areas in which genetic manipulation is of value, including the following:

- Basic research on gene structure and function
- Production of useful proteins by novel methods
- Generation of transgenic plants and animals
- Medical diagnosis and treatment
- Genome analysis by DNA sequencing

The mainstay of genetic manipulation is the ability to isolate a single DNA sequence from the genome. This is the essence of gene cloning and can be considered as a series of four steps (Fig. 1.1). Successful completion of these steps provides the genetic engineer with a specific DNA sequence, which may then be used for a variety of purposes. A useful analogy is to consider gene cloning as a form of molecular agriculture, enabling the production of large amounts (in genetic engineering this means micrograms or milligrams) of a particular DNA sequence. Even in the era of large-scale sequencing projects,

this ability to isolate a particular gene sequence is still a major aspect of gene manipulation carried out on a day-to-day basis in research laboratories worldwide.

One aspect of the new genetics that has given cause for concern is the debate surrounding the potential applications of the technology. The term *genethics* has been coined to describe the ethical problems that exist in modern genetics, which are likely to increase in both number and complexity as genetic engineering technology becomes more sophisticated. The use of transgenic plants and animals, investigation of the human genome, gene therapy, and many other topics are of concern – not just to the scientist, but to the population as a whole. Recent developments in genetically modified foods have provoked a public backlash against the technology. Additional developments in the cloning of organisms, and in areas such as *in vitro* fertilisation and xenotransplantation, raise further questions. Although organismal cloning is not strictly part of gene manipulation technology, because this is an area of much concern and can be considered genetic engineering in its broadest sense. Research on stem cells and the potential therapeutic benefits that this research may bring, is another area of concern that is part of the general advance in genetic technology.

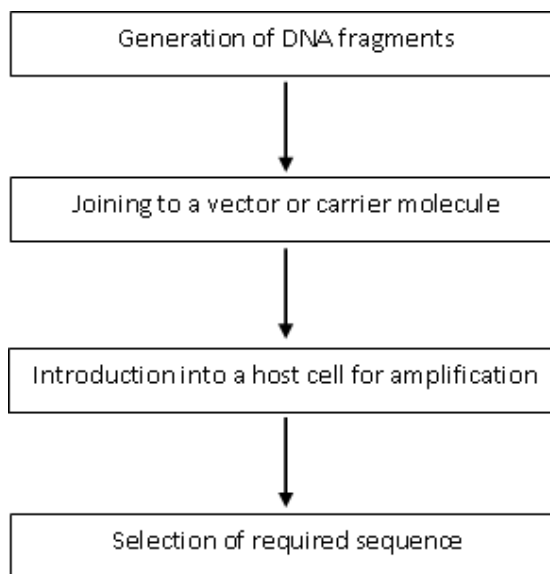

**Fig 1.1**

Taking all the potential costs and benefits into account, it remains to be seen if we can use genetic engineering for the overall benefit of mankind and avoid the misuse of technology that often accompanies scientific achievement.

### **11.2.1 Laying the foundations**

Although the techniques used in gene manipulation are relatively new, it should be remembered that development of these techniques was dependent on the knowledge and expertise provided by microbial geneticists. We can consider the development of genetics as falling into three main eras i.e. Mendelian classical genetics, Microbial genetics and Gene manipulation. The science of genetics really began with the rediscovery of Gregor Mendel's work at the turn of the century, and the next 40 years or so saw the elucidation of the principles of inheritance and genetic mapping. Microbial genetics became established in the mid 1940s, and the role of DNA as the genetic material was confirmed. During this period great advances were made in understanding the mechanisms of gene transfer between bacteria, and a broad knowledge base was established from which later developments would emerge.

The discovery of the structure of DNA by James Watson and Francis Crick in 1953 provided the stimulus for the development of genetics at the molecular level, and the next few years saw a period of intense activity and excitement as the main features of the gene and its expression were determined. This work culminated with the establishment of the complete genetic code in 1966 - the stage was now set for the appearance of the new genetics.

### **11.2.2 First steps**

In the late 1960s there was a sense of frustration among scientists working in the field of molecular biology. Research had developed to the point where progress was being hampered by technical constraints, as the elegant experiments that had helped to decipher the genetic code could not be extended to investigate the gene in more detail. However, a number of developments provided the necessary stimulus for gene manipulation to become a reality. In 1967 the enzyme DNA ligase was isolated. This enzyme can join two strands of DNA together, a prerequisite for the construction of recombinant molecules, and can be regarded as a sort of molecular glue. This was followed by the isolation of the first restriction enzyme in 1970, a major milestone in the development of genetic engineering. Restriction enzymes are essentially molecular scissors that cut DNA at precisely defined sequences. Such enzymes can be used to produce fragments of DNA that are suitable for joining to other

fragments. Thus, by 1970, the basic tools required for the construction of recombinant DNA were available.

The first recombinant DNA molecules were generated at Stanford University in 1972, utilizing the cleavage properties of restriction enzymes (scissors) and the ability of DNA ligase to join DNA strands together (glue). The importance of these first tentative experiments cannot be over estimated. Scientists could now join different DNA molecules together and could link the DNA of one organism to that of a completely different organism. The methodology was extended in 1973 by joining DNA fragments to the plasmid pSC101, which is an extrachromosomal element isolated from the bacterium *Escherichia coli*. These recombinant molecules behaved as replicons; that is, they could replicate when introduced into *E.coli* cells. Thus, by creating recombinant molecules *in vitro*, and placing the construct in a bacterial cell where it could replicate *in vivo*, specific fragments of DNA could be isolated from bacterial colonies that formed clones (colonies formed from a single cell, in which all cells are identical) when grown on agar plates. This development marked the emergence of the technology that became known as gene cloning (Fig. 1.2). The discoveries in 1972 and 1973 triggered what is perhaps the biggest scientific revolution of all -- the new genetics. The use of the new technology spread very quickly, and a sense of urgency and excitement prevailed. This was dampened somewhat by the realization that the new technology could give rise to potentially harmful organisms exhibiting undesirable characteristics. It is to the credit of the biological community that measures were adopted to regulate the use of gene manipulation and that progress in contentious areas was limited until more information became available regarding the possible consequences of the inadvertent release of organisms containing recombinant DNA. However, the development of genetically modified organisms (GMOs), particularly crop plants, has re-opened the debate about the safety of these organisms and the consequences of releasing GMOs into the environment. In addition, many of the potential medical benefits of gene manipulation, genetics, and cell biology pose ethical questions that may not be easy to answer.

---

### **11.3 Concept of culture**

---

Culture is an active growth of microorganism under proper condition. A culture containing only one kind of microorganism is axenic culture. The culture containing obtained from single cell is called pure culture. The culture containing only two kinds of microorganism is known as two membered

culture. The culture containing more than one kind of microorganism is known as mixed culture.

### **11.3.1 Media**

Media is an artificially prepared mixture of various nutrients, in appropriate concentration and is prepared by considering the biochemical requirements of microbe. (Plural-Media, singular-Medium)

Media are used in laboratory for cultivation of bacteria. They must supply all of the necessary nutrients required for the cellular growth and maintenance of the organisms. A wide variety of culture media are employed by bacteriologist for the isolation, growth and maintenance of pure cultures and also for the identification of bacteria according to their biochemical and physiological properties. A culture medium must supply suitable carbon and energy sources and other nutrients, sometimes including growth factors. It is important to note that no one medium will support the growth of all microorganisms.

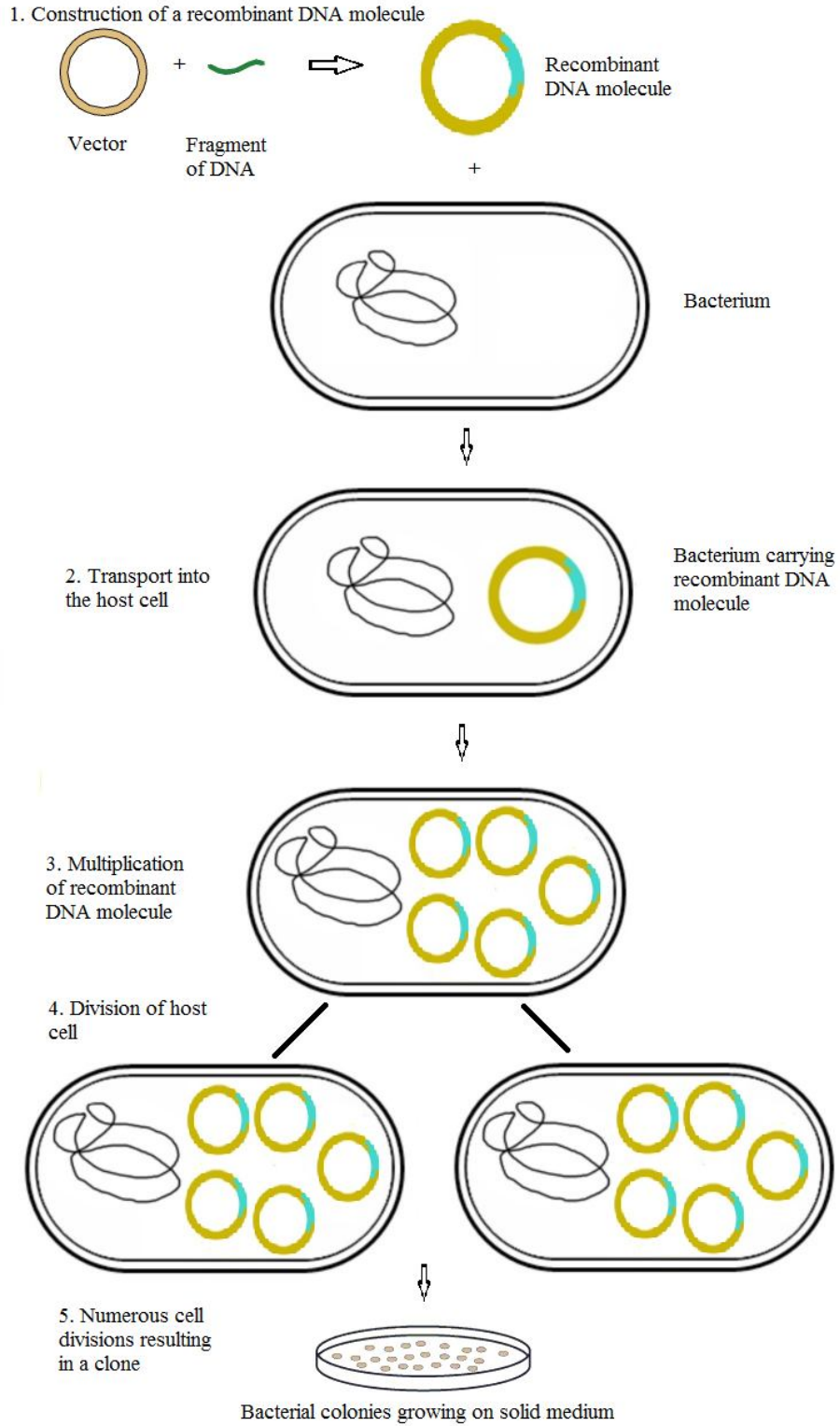

**Fig 1.2**

### 11.3.2 Common constituents of culture media

1. Water – It is essential for the growth of all microorganisms. It should be free from any chemicals (high mineral concentration.) which inhibit bacterial growth.
2. Sodium chloride, other electrolytes (potassium, magnesium, iron, calcium) – NaCl<sub>2</sub> is essential ingredient of most culture media. Sulphates are required as a source of sulphur. Phosphates as a source of phosphorus.
3. Peptone (water-soluble) (animal or plant) (pepsin, trypsin or by an acid) – It is obtained from the digestion of protein materials with proteolytic enzymes. It contains a mixture of amino acids, carbohydrates, mineral salts and polypeptides.
4. Meat extract, yeast extract – It is used to enrich media. It contain protein degradation products, carbohydrates, inorganic salts and some growth factors
5. Carbohydrates (simple; arabinose, glucose, sucrose, maltose. complex; glycogen, glycerol) – It provide bacteria with carbon and energy. It assists in the differentiation of bacteria (indicator).
6. Agar – It is a complex polysaccharide extracted commercially from a variety of seaweed (red marine algae). It is used as a solidifying agent (melt at 90°C and solidify at approximately 40°C), generally in a 1.5 to 2% concentration. (semi solid: 0.4-0.5%; transport media: Aimes).

### 1.3.3 Types of media

Physical State (Medium consistency)	Chemical Constituents	Functional Type
<ol style="list-style-type: none"> <li>1. Liquid</li> <li>2. Semisolid</li> <li>3. Solid</li> </ol>	<ol style="list-style-type: none"> <li>1. Synthetic (Chemically defined)</li> <li>2. Non-Synthetic (Chemically not defined)</li> </ol>	<ol style="list-style-type: none"> <li>1. Enrichment</li> <li>2. Selective</li> <li>3. Differential</li> <li>4. Transport</li> <li>5. Anaerobic</li> </ol>



**1. Culture media are classified into several categories depending on Physical State (Media consistency):**

Culture media are liquid, semi-solid or solid and biphasic.

**A) Liquid media:**

Media have liquid consistency. These are available for use in test-tubes, bottles or flasks. Liquid media are sometimes referred as “broths” (e.g. nutrient broth). In liquid medium, bacteria grow uniformly producing general turbidity. Certain aerobic bacteria and those containing fimbriae (*Vibrio* & *Bacillus*) are known to grow as a thin film called ‘surface pellicle’ on the surface of undisturbed broth. *Bacillus anthracis* is known to produce stalactite growth on ghee containing broth. Sometimes the initial turbidity may be followed by clearing due to autolysis, which is seen in pneumococci. Long chains of Streptococci when grown in liquid media tend to entangle and settle to the bottom forming granular deposits. Liquid media tend to be used when a large number of bacteria have to be grown. These are suitable to grow bacteria when the numbers in the inoculum is suspected to be low. Inoculating in the liquid medium also helps to dilute any inhibitors of bacterial growth. This is the practical approach in blood cultures. Culturing in liquid medium can be used to obtain viable count (dilution methods). Properties of bacteria are not visible in liquid media and presence of more than one type of bacteria cannot be detected.

**B) Solid media:**

If solidifying agent is added in medium, due to its gel like nature it confers solid consistency to media. Any liquid medium can be rendered by the addition of certain solidifying agents. Agar agar (simply called agar) is the most commonly used solidifying agent. It is an unbranched polysaccharide obtained from the cell membranes of some species of red algae such as the genera *Gelidium*. Agar is composed of two long-chain polysaccharides (70% agarose and 30% agaric acid). It melts at 95°C (sol) and solidifies at 42°C (gel), doesn't contribute any nutritive property, it is not hydrolyzed by most bacteria and is usually free from growth promoting or growth retarding substances. However, it may be a source of calcium & organic ions. Most commonly, it is used at concentration of 1-3% to make a solid agar medium. New Zealand agar has more gelling capacity than the Japanese agar. Agar is available as fibres (shreds) or as powders.

### **C) Semi-solid agar:**

If agar or any solidifying agent is added in low concentration then it confers semisolid consistency to media. By reducing the amount of agar to 0.2-0.5% semi-solid medium can be prepared. Such media are fairly soft and are useful in demonstrating bacterial motility and separating motile from non-motile strains (U-tube and Cragie's tube). Certain transport media such as Stuart's and Amies media are semi-solid in consistency. Hugh & Leifson's oxidation fermentation test medium as well as mannitol motility medium is also semi-solid.

### **D) Biphasic media:**

Sometimes, a culture system comprises of both liquid and solid medium in the same bottle. This is known as biphasic medium (Castaneda system for blood culture). The inoculum is added to the liquid medium and when subcultures are to be made, the bottle is simply tilted to allow the liquid to flow over the solid medium. This obviates the need for frequent opening of the culture bottle to subculture.

Besides agar, egg yolk and serum too can be used to solidify culture media. While serum and egg yolk are normally liquid, they can be rendered solid by coagulation using heat. Serum containing medium such as Loeffler's serum slope and egg containing media such as Lowenstein Jensen medium and Dorset egg medium are solidified as well as disinfected by a process of inspissations.

## **2. Classification based on nutritional component:**

Media can be classified as simple, complex and synthetic (or defined). While most of the nutritional components are constant across various media, some bacteria need extra nutrients. Those bacteria that are able to grow with minimal requirements are said to non-fastidious and those that require extra nutrients are said to be fastidious. Simple media such as peptone water, nutrient agar can support most non-fastidious bacteria.

### **A) Synthetic (chemically-defined) media**

In such type of media, the exact chemical composition is known. Defined media are usually composed of pure chemicals. A defined minimal medium is a medium if it provides only the exact nutrients (including any growth factors) needed by the organism for growth. The use of defined minimal media requires the investigator to know the exact nutritional requirements of the organisms under investigation. Chemically defined media are of value in studying the

minimal nutritional requirements of microorganisms, for enrichment culture, and for a wide variety of physiological studies.

An example of a synthetic medium (used for the growth of *Bacillus megatarium*; gm/L) – Sucrose-10.0gm, K<sub>2</sub>HPO<sub>4</sub>-2.5gm, KH<sub>2</sub>PO<sub>4</sub>-2.5gm, (NH<sub>4</sub>)<sub>2</sub>HPO<sub>4</sub>-1.0gm, MgSO<sub>4</sub>·7H<sub>2</sub>O-0.20gm, FeSO<sub>4</sub>·7H<sub>2</sub>O-0.01gm, MnSO<sub>4</sub>·7H<sub>2</sub>O-0.007gm, Water-1L, pH-7.0.

### **B) Complex (undefined) media**

It is the medium in which the exact chemical constitution of the medium is not known. Complex media usually contain complex materials of biological origin such as blood or milk or yeast extract or beef extract and peptone; the exact chemical composition of which is obviously undetermined. Complex media usually provide the full range of growth factors that may be required by an organism, so they may be more easily used to cultivate unknown bacteria or bacteria whose nutritional requirements are complex.

An example of complex media nutrient agar, generally used for isolation of various bacteria is Peptone-5.0gm, Beef extract-3.0gm, Sodium chloride-5.0gm, Agar-15.0gm, Distilled water-1L, pH-7.4.

**3. Classification based on functional use or application:** These include basal media, enriched media, selective/enrichment media, indicator/differential media, transport media and holding media.

#### **A) Basal media:**

These are basically simple media that supports most non-fastidious bacteria. Peptone water, nutrient broth and nutrient agar considered basal medium.

#### **B) Enriched media:**

Addition of extra nutrients in the form of blood, serum, egg yolk etc, to basal medium makes them enriched media. Enriched media are used to grow nutritionally demanding (fastidious) bacteria. Blood agar, chocolate agar, Loeffler's serum slope etc are few of the enriched media.

#### **C) Selective and enrichment media:**

The medium, which has component(s) added to it in such a concentration that it will inhibit or prevent the growth of certain types or species of bacteria and/or promote the growth of desired species. They are designed to inhibit unwanted commensal or contaminating bacteria and help to recover pathogen from a mixture of bacteria. While selective media are agar based, enrichment media

are liquid in consistency. Both these media serve the same purpose. Any agar media can be made selective by addition of certain inhibitory agents that don't affect the pathogen. Various approaches to make a medium selective include addition of antibiotics, dyes, chemicals, alteration of pH or a combination of these.

**D) Enrichment media:**

These are liquid media that also serves to inhibit commensals in the clinical specimen. Selenite F broth, tetrathionate broth and alkaline peptone water are used to recover pathogens from fecal specimens.

**E) Differential media or indicator media:**

Certain media are designed in such a way that different bacteria can be recognized on the basis of their colony colour. Various approaches include incorporation of dyes, metabolic substrates etc, so that those bacteria that utilize them appear as differently coloured colonies. Such media are called differential media or indicator media. Exmples: MacConkey's agar, CLED agar, TCBS agar, XLD agar etc.

**F) Transport media:**

Clinical specimens must be transported to the laboratory immediately after collection to prevent overgrowth of contaminating organisms or commensals. This can be achieved by using transport media. Such media prevent drying (desiccation) of specimen, maintain the pathogen to commensal ratio and inhibit overgrowth of unwanted bacteria. Some of these media (Stuart's & Amie's) are semi-solid in consistency. Addition of charcoal serves to neutralize inhibitory factors. Cary Blair medium and Venkatraman Ramakrishnan medium are used to transport feces from suspected cholera patients. Sach's buffered glycerol saline is used to transport feces from patients suspected to be suffering from bacillary dysentery.

**G) Anaerobic media:**

Anaerobic bacteria need special media for growth because they need low oxygen content, reduced oxidation –reduction potential and extra nutrients. Media for anaerobes may have to be supplemented with nutrients like hemin and vitamin K. Boiling the medium serves to expel any dissolved oxygen. Addition of 1% glucose, 0.1% thioglycollate, 0.1% ascorbic acid, 0.05% cysteine or red hot iron filings can render a medium reduced. Robertson cooked meat that is commonly used to grow Clostridium spp medium contain a 2.5 cm

column of bullock heart meat and 15 ml of nutrient broth. Before use the medium must be boiled in water bath to expel any dissolved oxygen and then sealed with sterile liquid paraffin. Methylene blue or resazurin is an oxidation reduction potential indicator that is incorporated in the thioglycollate medium. Under reduced condition, methylene blue is colourless.

---

## **1.4 Culture Methods**

---

### **1.4.1 Streak plate method**

In streak plate method bacterial suspension is separated on solid media by inoculating needle in various ways.

#### **Methodology**

Sterilize wire loop by holding it in Bunsen burner flame (Fig 1.3) and cool for few second. Aseptically remove a loopful of culture with wire loop. Raise the lid of sterile nutrient agar containing plate just high enough to insert the wire loop. With free arm movement spread the culture at one corner of plate. Then draw the first streak in first quadrant. Likewise streak in draw 2<sup>nd</sup>, 3<sup>rd</sup>, 4<sup>th</sup> quadrants. After each streak sterilize and cool the wire loop. The first streak will contain more number of microbes. The last streak should thin out the culture to give isolated colonies. Such inoculated nutrient agar-petri plate is then allowed to incubate at proper temperature and time. On the last streak well-isolated colonies will appear. Each colony represents pure growth of organism.

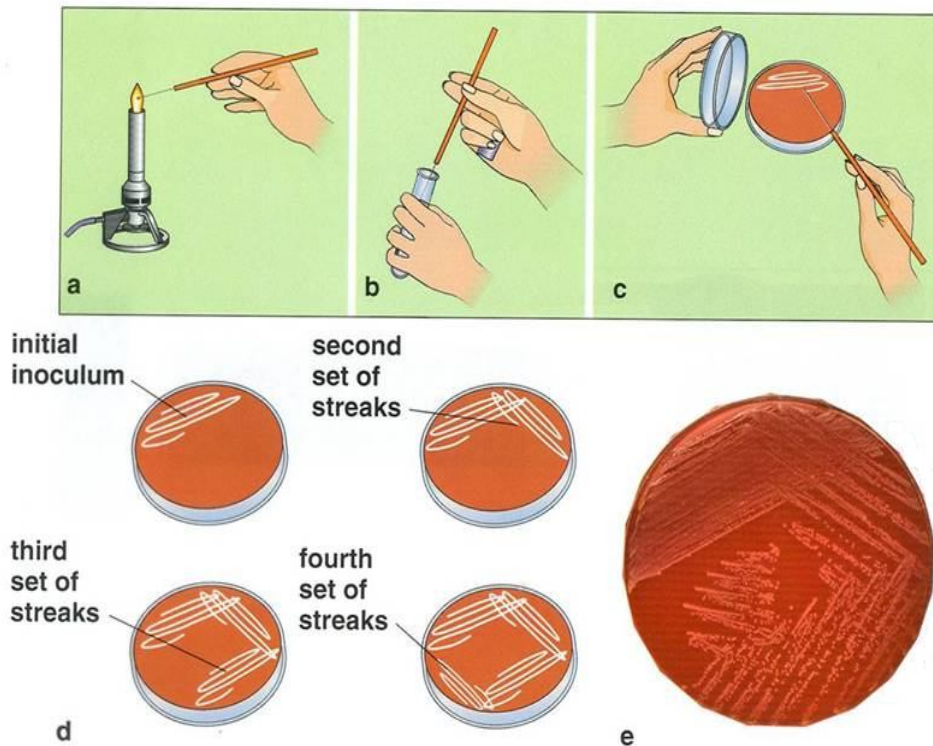

**Fig 1.3 Streak Plate Method**

#### **1.4.2 Pour plate method**

This involves the following steps (Fig 1.4):

- (A) Dilution of sample: the dilution of sample is an important step for this technique. Take 1gm/ml of sample, it is mixed with 99ml sterile saline, aseptically. This leads to  $1:10^2$  dilution of sample. Add 1ml of this mixture into a tube containing 9ml sterile saline with the help of a sterile pipette. This leads to  $1:10^3$  dilutions. Make several dilutions as above ( $1:10^4$  to  $1:10^6$ ). Select any dilution for further experiments.
- (B) Methodology of pour plate: Take 1ml mixture from any dilution (e.g.  $1:10^5$ ) with the help of a sterile pipette. Inoculate it into a sterile nutrient agar butt at  $45^\circ\text{C}$  (nutrient agar butt – It contains approx. 20ml nutrient agar medium in a tube, maintained in a liquefied condition at  $50^\circ\text{C}$ ). Shake the nutrient agar butt, in order to distribute the sample properly. Pour the content into a sterile empty petri-plate and allow solidifying. Incubate the plate at a proper temperature for 24 hours. Analyse the colonies qualitatively and quantitatively. Calculate the number of colonies on

agar surface. This will give the number of microorganisms in diluted sample.

To calculate the total number of microorganisms in the initial sample, multiply the number of colonies by diluting factor.

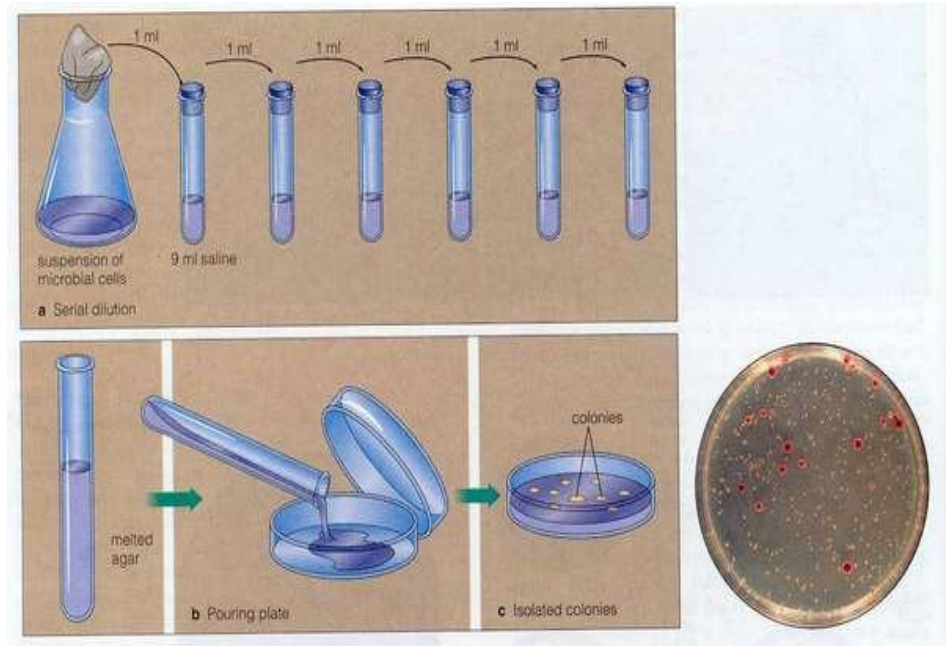

**Fig 1.4 Pour Plate Method**

#### **Drawbacks:**

1. The microorganisms are subjected to hot shock because liquid medium is maintained at 45°C temperature.
2. This method is unsuitable for isolating psychrophile bacteria.
3. This method is tedious, time consuming and requires skilled hands.

#### **1.4.3 Spread plate method**

The method in which bacterial suspension is uniformly distributed on solid agar by glass spreader is spread plate technique (Fig 1.5).

With the help of a sterile pipette add 1ml of given sample into sterile 99 saline containing flask and then add 1ml of this mixture into 9 ml saline containing tube. Repeat the process for several times in order to achieve a specific dilution.

Place 0.1ml of any prepared dilution on sterile nutrient agar plate with the help of a sterile pipette.

Sterilize a glass spreader by flaming after dipping in alcohol and allow it to cool between two burners.

Then spread the drop of suspension uniformly over the agar surface with the help of sterilized spreader.

Incubate the petri plate for 24 hours at appropriate temperature and observe it on next day. Calculate the number of colonies on agar surface. This will give the number of microorganisms in diluted sample.

To calculate the total number of microorganisms in the initial sample multiplies the number of colonies by dilution factor.

**Advantages:**

1. It is possible to enumerate the number of microorganisms in any given suspension by this method.
2. Another advantage of this method is that for any purposes a bacterial lawn – dense bacterial growth is required (example in microbiological assay). This method is appropriate for this purpose.
3. One of the advantages is that only surfaces colonies develop and hence are easy to pick up.

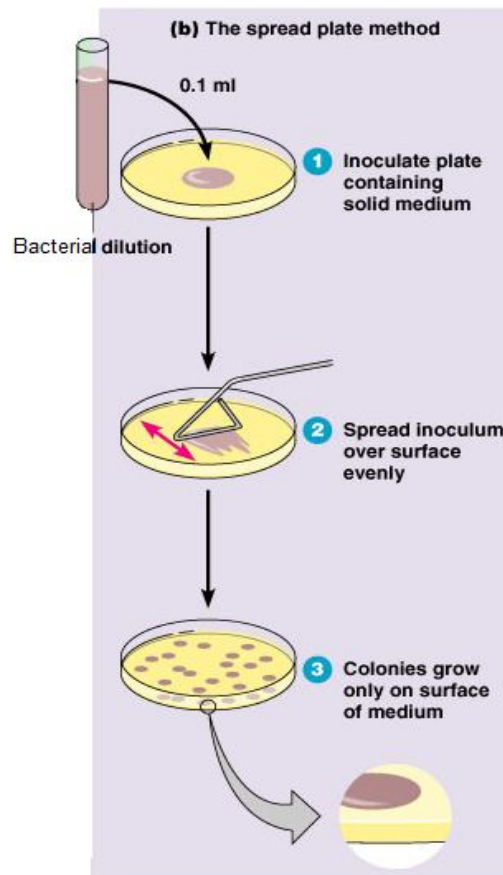

**Fig 1.5 Spread Plate Method**



#### **1.4.4 Roll tube method:**

R.E. Hugnate developed this method for cultivation of anaerobic bacteria. Many bacteria are killed by even momentary exposure of air. Cultivation of such microbes in routine atmospheric condition and by general technique is not possible.

Widely employed method for isolation of anaerobes is roll tube method.

Take test tube containing a few mls of molten agar medium. The medium should be reduced chemically to remove dissolved oxygen. This is possible by incorporation of several chemicals like sodium thioglycolate. The tube is tightly closed with butyl rubber bung (to maintain anaerobic condition).

The molten agar is inoculated with appropriate dilution of source of bacteria by insewing them through the rubber stopper with sterile syringe.

The tubes are then laid on their sides in ice and rolled until the agar solidifies in thin layer on the wall of tube. This procedure leads to separation of the microbes.

After incubation when colonies become visible, the bung is removed and isolated colonies are picked from agar with a needle or capillary tube. Whenever a tube is opened, entry of air is prevented by continuously passing stream of CO<sub>2</sub> or N<sub>2</sub> into tube. To ensure anaerobic condition, dye like resazurine must be incorporated into medium.

---

### **11.5 Restriction enzymes (restriction endonucleases)**

---

A restriction enzyme is a protein that recognizes a specific, short nucleotide sequence and cuts the DNA only at that specific site, which is known as restriction site or target sequence. They cleave the sugar - phosphate backbone of DNA strands. The vast majority of these enzymes have been isolated from bacteria, where they carry out a host - defense function for the cell. These enzymes recognize a specific DNA base sequence and cleave both strands of a double - stranded DNA molecule at or near the recognition site. All restriction enzymes fall into one of three classes, based upon their molecular structure and need for specific co - factors. Class I endonucleases have a molecular weight around 300,000 Daltons, are composed of non - identical sub - units, and require Mg<sup>2+</sup>, ATP (adenosine triphosphate), and SAM (S - adenosyl - methionine) as cofactors for activity. Class II enzymes are much smaller, with molecular weights in the range of 20,000 to 100,000 Daltons. They have identical sub - units and require only Mg<sup>2+</sup> as a cofactor. The Class III enzyme

is a large molecule, with a molecular weight of around 200,000 Daltons, composed of non - identical sub - units. These enzymes differ from enzymes of the other two classes in that they require both Mg<sup>2+</sup> and ATP but not SAM as co - factors. Class III endonucleases are the rarest of the three types.

Types I and III are rather complex and have only a limited role in genetic engineering. Type II restriction endonucleases, on the other hand, are the cutting enzymes that are so important in gene cloning.

### 11.5.1 Type II restriction endonucleases

The central feature of type II restriction endonucleases (which will be referred to simply as “restriction endonucleases” from now on) is that each enzyme has a specific recognition sequence at which it cuts a DNA molecule. A particular enzyme cleaves DNA at the recognition sequence and nowhere else. For example, the restriction endonuclease called PvuI (isolated from *Proteus vulgaris*) cuts DNA only at the hexanucleotide CGATCG. In contrast, a second enzyme from the same bacterium, called PvuII, cuts at a different hexanucleotide, in this case CAGCTG.

Many restriction endonucleases recognize hexanucleotide target sites, but others cut at four, five, eight, or even longer nucleotide sequences. Sau3A (from *Staphylococcus aureus* strain 3A) recognizes GATC, and AluI (*Arthrobacter luteus*) cuts at AGCT. There are also examples of restriction endonucleases with degenerate recognition sequences, meaning that they cut DNA at any one of a family of related sites. HinfI (*Haemophilus influenzae* strain Rf), for instance, recognizes GANTC, so cuts at GAATC, GATTC, GAGTC, and GACTC. The recognition sequences for some of the most frequently used restriction endonucleases are listed in Table 1.

**Table 1**

**The recognition sequences for some of the most frequently used restriction endonucleases.**

Enzyme	Organism	Recognition Sequence*	Blunt or Sticky End
<i>EcoRI</i>	<i>Escherichia coli</i>	GAATTC	Sticky
<i>BamHI</i>	<i>Bacillus amyloliquefaciens</i>	GGATCC	Sticky

<i>Bgl</i> III	<i>Bacillus globigii</i>	AGATCT	Sticky
<i>Pvu</i> I	<i>Proteus vulgaris</i>	CGATCG	Sticky
<i>Pvu</i> II	<i>Proteus vulgaris</i>	CAGCTG	Blunt
<i>Hind</i> III	<i>Haemophilus influenza</i> R <sub>d</sub>	AAGCTT	Sticky
<i>Hin</i> fI	<i>Haemophilus influenza</i> R <sub>f</sub>	GATC	Sticky
<i>Sau</i> 3A	<i>Staphylococcus aureus</i>	GATC	Sticky
<i>Alu</i> I	<i>Arthrobacter luteus</i>	AGCT	Blunt
<i>Taq</i> I	<i>Thermus aquaticus</i>	TCGA	Sticky
<i>Hae</i> III	<i>Haemophilus aegyptius</i>	GGCC	Blunt
<i>Not</i> I	<i>Nocardia otidis-caviarum</i>	GCGGCCGC	Sticky
<i>Sfi</i> I	<i>Streptomyces fimbriatus</i>	GGCCNNNNN GGCC	Sticky

\*The sequence shown is that of one strand, given in the 5' to 3' direction. "N" indicates any nucleotide. Note that almost all recognition sequences are palindromes: When both strands are considered they read the same in each direction, for example:

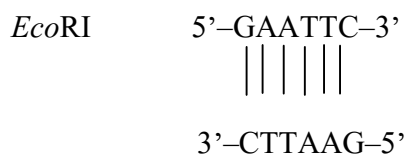

### 11.5.2 Nomenclature

Restriction enzymes are named for the organism from which they were first isolated using a naming system based on bacterial genus, species and strain. For example the name of the EcoRI and BamHI restriction enzymes were derived as shown Table 2.

**Table 2**  
**Nomenclature of restriction endonucleases**

Derivation of the name	Abbreviation	Meaning	Description
EcoRI	E	Escherichia	genus
	Co	coli	Specific epithet
	R	RY13	strain
	I	First identified (roman numeral)	Order of identification in the bacterium
BamHI	B	Bacillus	genus
	Am	amyloliquefaciens	Specific epithet
	H	H	strain
	I	First identified (roman numeral)	Order of identification in the bacterium

### 11.5.3 Blunt ends and sticky ends

The exact nature of the cut produced by a restriction endonuclease is of considerable importance in the design of a gene cloning experiment. Many restriction endonucleases make a simple double-stranded cut in the middle of the recognition sequence (Fig 1.6a), resulting in a blunt end or flush end. PvuII and AluI are examples of blunt end cutters.

Other restriction endonucleases cut DNA in a slightly different way. With these enzymes the two DNA strands are not cut at exactly the same position. Instead the cleavage is staggered, usually by two or four nucleotides, so that the resulting DNA fragments have short single-stranded overhangs at each end (Fig 1.6b). These are called sticky or cohesive ends, as base pairing between them can stick the DNA molecule back together again. One important feature of sticky end enzymes is that restriction endonucleases with different recognition sequences may produce the same sticky ends. BamHI (recognition sequence

GGATCC) and BglII (AGATCT) are examples—both produce GATC sticky ends (Figure 1.6c). The same sticky end is also produced by Sau3A, which recognizes only the tetranucleotide GATC. Fragments of DNA produced by cleavage with either of these enzymes can be joined to each other, as each fragment carries a complementary sticky end.

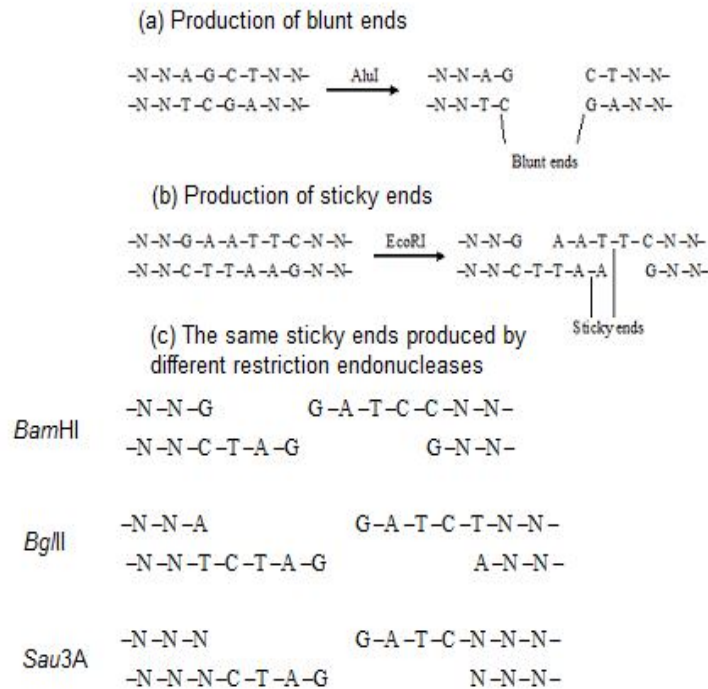

Fig 1.6 The ends produced by cleavage of DNA with different restriction endonucleases. (a) A blunt end produced by *AluI*. (b) A sticky end produced by *EcoRI*. (c) The same ends produced by *BamHI*, *BglII* and *Sau3A*.

### 11.5.4 The frequency of recognition sequences in a DNA molecule

The number of recognition sequences for a particular restriction endonuclease in a DNA molecule of known length can be calculated mathematically. A tetranucleotide sequence (e.g., GATC) should occur once every  $4^4 = 256$  nucleotides, and a hexanucleotide (e.g., GGATCC) once every  $4^6 = 4096$  nucleotides. These calculations assume that the nucleotides are ordered in a random fashion and that the four different nucleotides are present in equal proportions (i.e., the GC content = 50%). In practice, neither of these assumptions is entirely valid. For example, the  $\lambda$  DNA molecule, at 49 kb, should contain about 12 sites for a restriction endonuclease with a

hexanucleotide recognition sequence. In fact, many of these recognition sites occur less frequently (e.g., six for BglIII, five for BamHI, and only two for Sall), a reflection of the fact that the GC content for  $\lambda$  is rather less than 50% (Figure 1.7a).

Furthermore, restriction sites are generally not evenly spaced out along a DNA molecule. If they were, then digestion with a particular restriction endonuclease would give fragments of roughly equal sizes. Figure 1.7b shows the fragments produced by cutting  $\lambda$  DNA with BglIII, BamHI, and Sall. In each case there is a considerable spread of fragment sizes, indicating that in  $\lambda$  DNA the nucleotides are not randomly ordered.

The lesson to be learned from Figure 1.7 is that although mathematics may give an idea of how many restriction sites to expect in a given DNA molecule, only experimental analysis can provide the true picture. We must therefore move on to consider how restriction endonucleases are used in the laboratory.

---

## 11.6 Cloning vectors

---

Cloning vector is a DNA molecule that carries foreign DNA into a host cell, replicates inside a bacterial (or yeast) cell and produces many copies of itself and the foreign DNA. The cloned genes in these vectors are not expected to express themselves at transcription or translation level. These vectors are used for creating genomic libraries or for preparing the probes or in genetic engineering experiments or other basic studies. Selection of cloning vectors depends on the objective of cloning experiment, ease of working, knowledge existing about the vector, suitability and reliability. A variety of small, autonomously replicating molecules are used as cloning vectors. Vectors that are commonly used in cloning experiments are presented in the Table 3.

### 11.6.1 Plasmids as vectors

Plasmids are circular DNA molecules that lead an independent existence in the bacterial cells (Figure 1.8). They are naturally occurring, extra chromosomal DNA fragments that are stably inherited from one generation to another generation in an extra chromosomal state. The incorporation of DNA fragments into plasmid vectors not only allow foreign DNA to be replicated in cloned cells for later isolation and identification, but can also be designed so that cells transcribe and translate this DNA into protein.

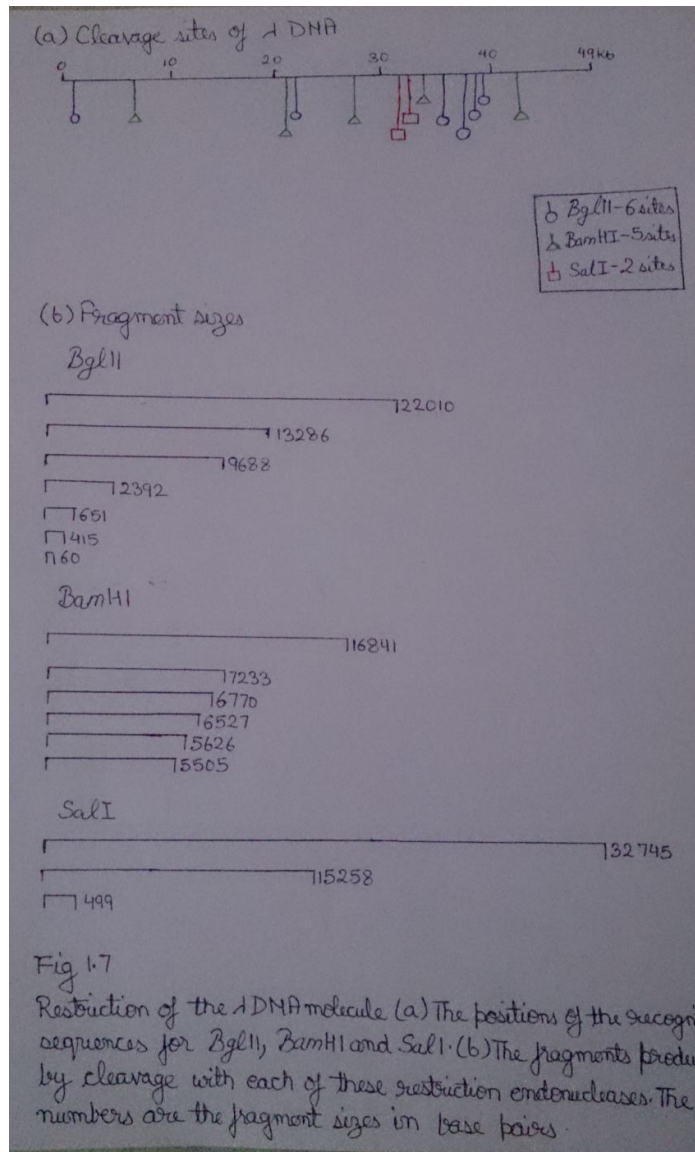

Plasmids almost always carry one or more genes, and often these genes are responsible for a useful characteristic displayed by the host bacterium. For example, the ability to survive in normally toxic concentrations of antibiotics such as chloramphenicol or ampicillin is often due to the presence in the bacterium of a plasmid carrying antibiotic resistance genes. In the laboratory, antibiotic resistance is often used as a selectable marker to ensure that bacteria in a culture contain a particular plasmid.

**Table 3. Commonly used vectors used in molecular biology**

S. No.	Vectors	Important uses of vectors	Maximum insert size in kb	Examples
1.	Plasmid	General DNA manipulation	10-20	PBR322, PUC18
2.	$\lambda$ (Insertion)	Construction of cDNA libraries	~10	$\lambda$ gt11
3.	$\lambda$ (Replacement)	Construction of genomic libraries	~23	$\lambda$ ZAP, EMBL4
4.	Cosmid	Construction of genomic libraries	~44	PJB8
5.	Phagemid	General DNA manipulation <i>In vitro</i> mutagenesis	10-20	PBluescript
6.	M13	DNA sequencing <i>In vitro</i> mutagenesis	8-9	M13, mp18
7.	BAC	Construction of genomic libraries	130-150	PBAC108L
8.	YAC	Construction of genomic libraries	1000-2000	PYAC4
9.	PAC	Construction of genomic libraries	75-90	PAd10SacBII



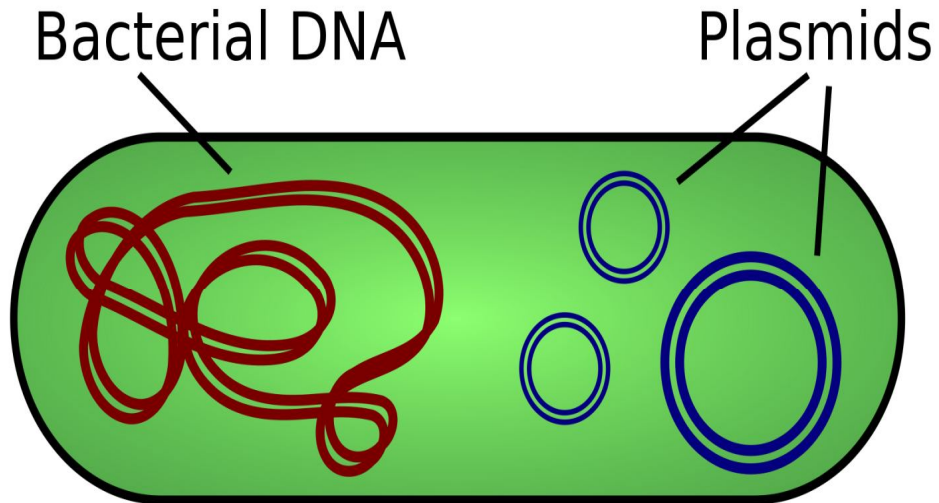

Fig 1.8 Plasmids: Independent genetic elements found in bacteria

Most plasmids possess at least one DNA sequence that can act as an origin of replication, so they are able to multiply within the cell independently of the main bacterial chromosome (Figure 1.9a). The smaller plasmids make use of the host cell's own DNA replicative enzymes in order to make copies of themselves, whereas some of the larger ones carry genes that code for special enzymes that are specific for plasmid replication. A few types of plasmid are also able to replicate by inserting themselves into the bacterial chromosome (Figure 1.9b). These integrative plasmids or episomes may be stably maintained in this form through numerous cell divisions, but always at some stage exist as independent elements.

They are widely distributed throughout the prokaryotes and range in size from approximately 1500bp to over 300kbp. Common plasmid vectors are 2-4kb in length and capable of carrying 15 kb of foreign DNA (Hartwell et al., 2004). Most plasmids exist as closed circular double stranded DNA molecules that often confer a particular phenotype on to the bacterial cells in which they are replicated. Few types of plasmids are also able to replicate by inserting themselves into the bacterial chromosomes which are called episomes. Plasmids can be classified into two groups namely conjugative plasmid and non conjugative plasmid. Conjugative plasmids can initiate their own transfer between bacteria by the process of conjugation, which requires functions specified by the tra (transfer) and mob (mobilizing) regions carried on the plasmid. Non-conjugative plasmids are not self transmissible, but may be mobilized by a conjugation proficient plasmid if their mob region is functional.

A further classification is based on the number of copies of the plasmid found in the host cell, a feature known as copy number. Depending on the frequency common plasmid vectors can be classified as low copy number (<10) or high copy number (>20). Low copy number plasmids tend to exhibit stringent control of DNA replication with replication of pDNA closely tied to host cell chromosomal DNA replication. High copy number plasmids are termed as relaxed plasmids, with DNA replication not depend on host cell chromosomal DNA replication. Choice of vectors with low or high copy depends on the objective of the cloning. If the target is to clone and express a gene for synthesis of particular protein or secondary metabolites in bacterial system for higher production, high copy number is preferred. But in transformation experiments, low copy plasmids are automatic choice.

The most useful classification of naturally occurring plasmids are based on the main characteristics coded by the plasmid genes.

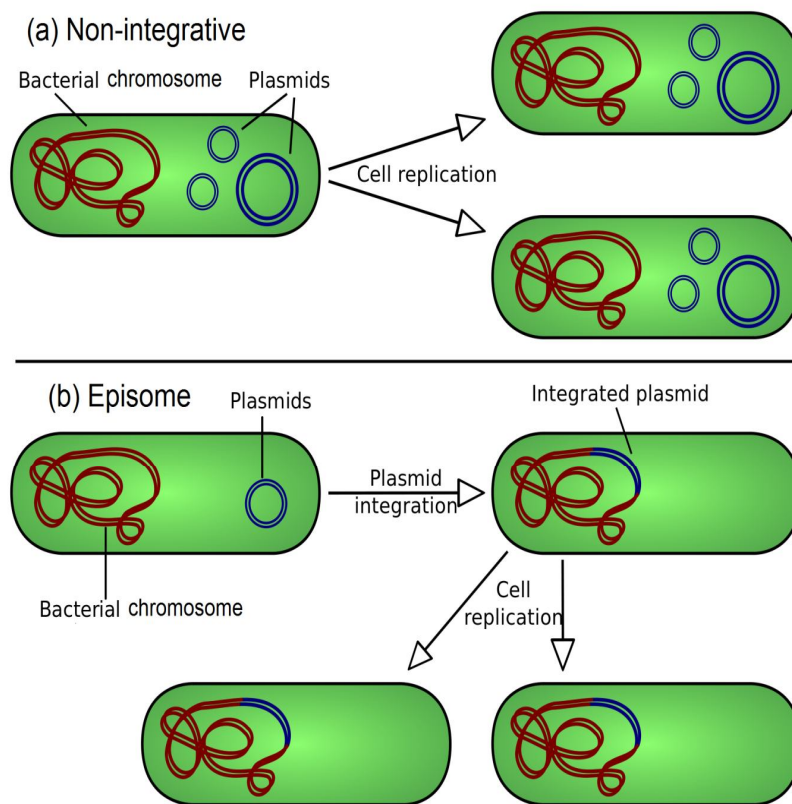

Fig 1.9 Replication strategies for (a) a non-integrative plasmid and (b) an episome

### **11.6.1.1 Size and copy number**

The size and copy number of a plasmid are particularly important as far as cloning is concerned. We have already mentioned the relevance of plasmid size and stated that less than 10 kb is desirable for a cloning vector. Plasmids range from about 1.0 kb for the smallest to over 250 kb for the largest plasmids, so only a few are useful for cloning purposes. However, larger plasmids can be adapted for cloning under some circumstances.

The copy number refers to the number of molecules of an individual plasmid that are normally found in a single bacterial cell. The factors that control copy number are not well understood. Some plasmids, especially the larger ones, are stringent and have a low copy number of perhaps just one or two per cell; others, called relaxed plasmids, are present in multiple copies of 50 or more per cell. Generally speaking, a useful cloning vector needs to be present in the cell in multiple copies so that large quantities of the recombinant DNA molecule can be obtained.

### **11.6.1.2 Conjugation and compatibility**

Plasmids fall into two groups: conjugative and non conjugative. Conjugative plasmids are characterized by the ability to promote sexual conjugation between bacterial cells, a process that can result in a conjugative plasmid spreading from one cell to all the other cells in a bacterial culture. Conjugation and plasmid transfer are controlled by a set of transfer or tra genes, which are present on conjugative plasmids but absent from the non-conjugative type. However, a non conjugative plasmid may, under some circumstances, be cotransferred along with a conjugative plasmid when both are present in the same cell.

Several different kinds of plasmid may be found in a single cell, including more than one different conjugative plasmid at any one time. In fact, cells of *E. coli* have been known to contain up to seven different plasmids at once. To be able to coexist in the same cell, different plasmids must be compatible. If two plasmids are incompatible then one or the other will be rapidly lost from the cell. Different types of plasmid can therefore be assigned to different incompatibility groups on the basis of whether or not they can coexist, and plasmids from a single incompatibility group are often related to each other in various ways. The basis of incompatibility is not well understood, but events during plasmid replication are thought to underlie the phenomenon.

### **11.6.1.3 Plasmid classification**

The most useful classification of naturally occurring plasmids is based on the main characteristic coded by the plasmid genes. The five major types of plasmid according to this classification are as follows:

Fertility or F plasmids carry only *tra* genes and have no characteristic beyond the ability to promote conjugal transfer of plasmids. A well-known example is the F plasmid of *E. coli*.

Resistance or R plasmids carry genes conferring on the host bacterium resistance to one or more antibacterial agents, such as chloramphenicol, ampicillin, and mercury. R plasmids are very important in clinical microbiology as their spread through natural populations can have profound consequences in the treatment of bacterial infections. An example is RP4, which is commonly found in *Pseudomonas*, but also occurs in many other bacteria.

Col plasmids code for colicins, proteins that kill other bacteria. An example is ColE1 of *E. coli*.

Degradative plasmids allow the host bacterium to metabolize unusual molecules such as toluene and salicylic acid, an example being TOL of *Pseudomonas putida*.

Virulence plasmids confer pathogenicity on the host bacterium; these include the Ti plasmids of *Agrobacterium tumefaciens*, which induce crown gall disease on dicotyledonous plants.

### **11.6.1.4 Plasmids in organisms other than bacteria**

Although plasmids are widespread in bacteria they are by no means as common in other organisms. The best characterized eukaryotic plasmid is the 2  $\mu$ m circle that occurs in many strains of the yeast *Saccharomyces cerevisiae*. The discovery of the 2  $\mu$ m plasmid was very fortuitous as it allowed the construction of cloning vectors for this very important industrial organism. However, the search for plasmids in other eukaryotes (such as filamentous fungi, plants and animals) has proved disappointing, and it is suspected that many higher organisms simply do not harbor plasmids within their cells.

### **11.6.1.5 Cloning vectors based on E. coli plasmids**

The simplest cloning vectors, and the ones most widely used in gene cloning, are those based on small bacterial plasmids. A large number of different plasmid vectors are available for use with *E. coli*, many obtainable from commercial suppliers. They combine ease of purification with desirable

properties such as high transformation efficiency, convenient selectable markers for transformants and recombinants, and the ability to clone reasonably large (up to about 8 kb) pieces of DNA. Most “routine” gene cloning experiments make use of one or other of these plasmid vectors. One of the first vectors to be developed was pBR322.

#### **11.6.1.6 The nomenclature of plasmid cloning vectors**

The name “pBR322” conforms with the standard rules for vector nomenclature:

- “p” indicates that this is indeed a plasmid.
- “BR” identifies the laboratory in which the vector was originally constructed (BR stands for Bolivar and Rodriguez, the two researchers who developed pBR322).
- “322” distinguishes this plasmid from others developed in the same laboratory (there are also plasmids called pBR325, pBR327, pBR328, etc.).

#### **11.6.1.7 Features of pBR322**

The genetic and physical map of pBR322 (Figure 2.0) gives an indication of why this plasmid was such a popular cloning vector.

The first useful feature of pBR322 is its size. A cloning vector ought to be less than 10 kb in size, to avoid problems such as DNA breakdown during purification. pBR322 is 4363 bp, which means that not only can the vector itself be purified with ease, but so can recombinant DNA molecules constructed with it. Even with 6 kb of additional DNA, a recombinant pBR322 molecule is still a manageable size. The second feature of pBR322 is that, it carries two sets of antibiotic resistance genes. Either ampicillin or tetracycline resistance can be used as a selectable marker for cells containing the plasmid, and each marker gene includes unique restriction sites that can be used in cloning experiments. Insertion of new DNA into pBR322 that has been restricted with PstI, PvuI, or ScaI inactivates the amp<sup>R</sup> gene, and insertion using any one of eight restriction endonucleases (notably BamHI and HindIII) inactivates tetracycline resistance. This great variety of restriction sites that can be used for insertional inactivation means that pBR322 can be used to clone DNA fragments with any of several kinds of sticky end.

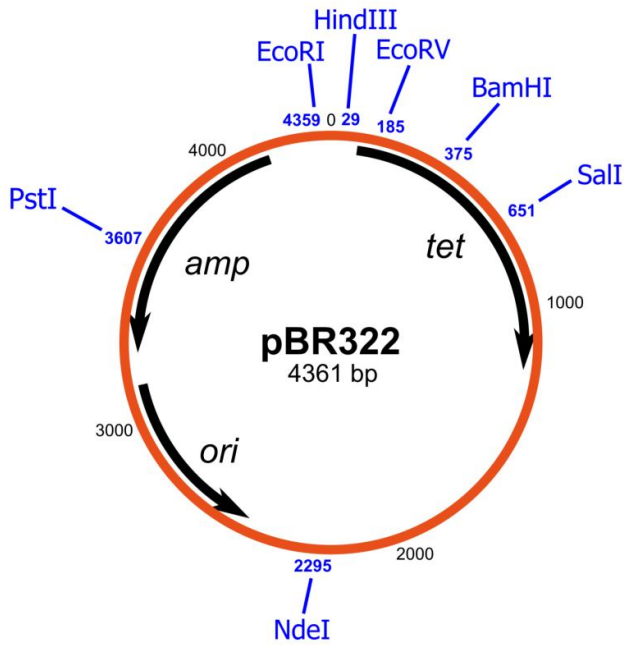

Fig 2.0 A map of pBR322 showing the positions of the ampicillin resistance (*amp<sup>r</sup>*) and tetracycline resistance (*tet<sup>r</sup>*) genes, the origin of replication (*ori*) and some of the most important restriction sites

A third advantage of pBR322 is that it has a reasonably high copy number. Generally there are about 15 molecules present in a transformed *E. coli* cell, but this number can be increased, up to 1000–3000, by plasmid amplification in the presence of a protein synthesis inhibitor such as chloramphenicol. An *E. coli* culture therefore provides a good yield of recombinant pBR322 molecules.

### 11.6.2 Phage as vectors

Bacteriophages are natural vectors that transduce bacterial DNA from one cell to another. Phage vectors have a natural advantage over plasmids that is they infect cells much more efficiently than plasmids transformed cells, so the yield of clones with phage vectors is usually higher. With phage vectors, clones are not colonies of cells, but plaques formed when a phage clears out a hole in a lawn of bacteria.

Bacteriophages, or phages as they are commonly known, are viruses that specifically infect bacteria. Like all viruses, phages are very simple in structure, consisting merely of a DNA (or occasionally ribonucleic acid (RNA)) molecule carrying a number of genes, including several for replication of the phage, surrounded by a protective coat or capsid made up of protein molecules.

Bacteriophage is a genetically complex but very extensively studied virus of *E.coli*. The DNA of phage is a linear duplex molecule of about 48.5kbp. About one third of genome is non essential and can be replaced with foreign DNA. DNA is packaged into infectious phage particles only if it is in between 40000 and 53000bp long, a limitation that can be used to ensure packaging of recombinant DNA only. Engineered vector of  $\lambda$  are of two major types that is insertion vectors and replacement vectors.

### 11.6.2.1 The phage infection cycle

The general pattern of infection, which is the same for all types of phage, is a three-step process (Figure 2.1):

- 1 The phage particle attaches to the outside of the bacterium and injects its DNA chromosome into the cell.
- 2 The phage DNA molecule is replicated, usually by specific phage enzymes coded by genes in the phage chromosome.
- 3 Other phage genes direct synthesis of the protein components of the capsid, and new phage particles are assembled and released from the bacterium.

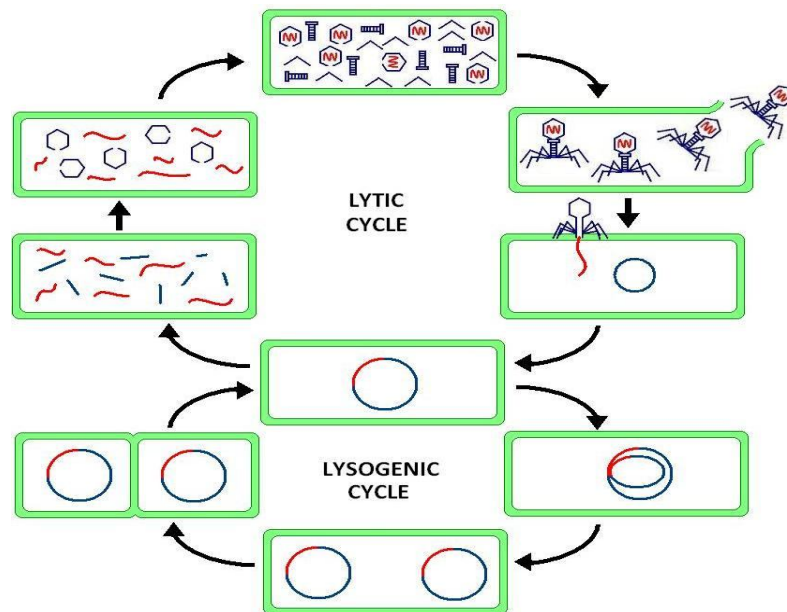

Fig 2.1 Infection cycle of bacteriophage

With some phage types the entire infection cycle is completed very quickly, possibly in less than 20 minutes. This type of rapid infection is called a lytic cycle, as release of the new phage particles is associated with lysis of the bacterial cell. The characteristic feature of a lytic infection cycle is that phage DNA replication is immediately followed by synthesis of capsid proteins, and the phage DNA molecule is never maintained in a stable condition in the host cell.

### **Lysogenic phages**

In contrast to a lytic cycle, lysogenic infection is characterized by retention of the phage DNA molecule in the host bacterium, possibly for many thousands of cell divisions. With many lysogenic phages the phage DNA is inserted into the bacterial genome, in a manner similar to episomal insertion (Figure 2.1). The integrated form of the phage DNA (called the prophage) is quiescent, and a bacterium (referred to as a lysogen) that carries a prophage is usually physiologically indistinguishable from an uninfected cell. However, the prophage is eventually released from the host genome and the phage reverts to the lytic mode and lyses the cell. The infection cycle of lysogenic phage is shown in Figure 2.1.

A limited number of lysogenic phages follow a rather different infection cycle. When M13 or a related phage infects *E. coli*, new phage particles are continuously assembled and released from the cell. The M13 DNA is not integrated into the bacterial genome and does not become quiescent. With these phages, cell lysis never occurs, and the infected bacterium can continue to grow and divide, albeit at a slower rate than uninfected cells.

Although there are many different varieties of bacteriophage, only  $\lambda$  (Fig 2.2) and M13 have found a major role as cloning vectors. We will now consider the properties of these two phages in more detail. Engineered vectors of  $\lambda$  are of two major types that is insertion vectors and replacement vectors

#### **11.6.2.2 Insertion and replacement vectors**

Once the problems posed by packaging constraints and by the multiple restriction sites had been solved, the way was open for the development of different types of  $\lambda$ -based cloning vectors. The first two classes of vector to be produced were  $\lambda$  insertion and  $\lambda$  replacement (or substitution) vectors.



### Insertion vector

With an insertion vector, a large segment of the non-essential region has been deleted, and two arms ligated together. An insertion vector possesses at least one unique restriction site into which new DNA can be inserted. The size of DNA fragment that an individual vector can carry depends of course on the extent to which the non-essential region has been deleted. Smaller foreign DNA can be packed here. Two popular insertion vectors are:

- $\lambda$ gt10:  $\lambda$ gt10 is a 43 kb double stranded DNA and can clone fragments of up to 7kb. It can carry up to 8kb of new DNA, inserted into a unique EcoRI site located in the CI gene. Insertional activation of this gene means that recombinants are distinguished as clear rather than turbid plaques. This vector gives clear plaques.
- $\lambda$  EZAPII:  $\lambda$ ZAPII with which insertion of up to 10 kb DNA into any of 6 restriction sites within a polylinker inactivates the lacZ' gene carried by the vector. Recombinants give clear rather than blue plaques on X-gal agar.

### Replacement vector

A  $\lambda$  replacement vector has two recognition sites for the restriction endonuclease used for cloning. These sites flank a segment of DNA that is replaced by the DNA to be cloned. These restriction sites flank a region known as stuffer fragment. Often the replaceable fragment (or “stuffer fragment” in cloning jargon) carries additional restriction sites that can be used to cut it up into small pieces, so that its own insertion during a cloning experiment is very unlikely. Replacement vectors are generally designed to carry large pieces of DNA than insertional vector can handle. Recombinant selection is often on the basis of size, with non-recombinant vectors being too small to be packaged into  $\lambda$  phage heads.

An example of replacement vectors is  $\lambda$ EMBL4

$\lambda$ EMBL4:  $\lambda$ EMBL4 can carry up to 20 kb of inserted DNA by replacing a segment flanked by pairs of EcoRI, BamHI and SalI sites. Any of these three restriction endonucleases can be used to remove the stuffer fragment, so DNA fragments with a variety of sticky ends can be cloned. Recombinant selection with  $\lambda$ EMBL4 can be on the basis of size, or can utilize the Spi phenotype.

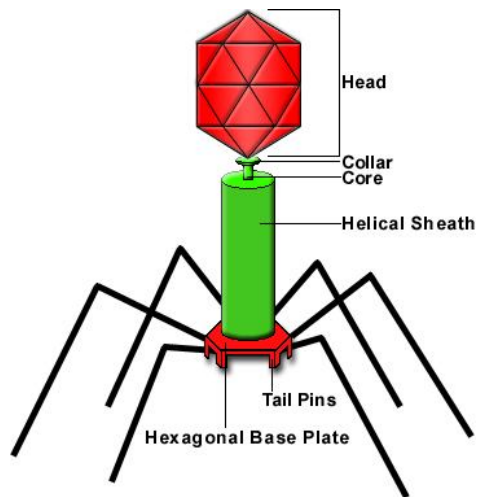

Fig 2.2 Head and Tail Bacteriophage

### 11.6.2.3 M13—a filamentous phage

M13 is an example of a filamentous phage and is completely different in structure from  $\lambda$ . Furthermore, the M13 DNA molecule is much smaller than the  $\lambda$  genome, being only 6407 nucleotides in length. It is circular and is unusual in that it consists entirely of single-stranded DNA.

The smaller size of the M13 DNA molecule means that it has room for fewer genes than the  $\lambda$  genome. This is possible because the M13 capsid is constructed from multiple copies of just three proteins (requiring only three genes), whereas synthesis of the  $\lambda$  head-and-tail structure involves over 15 different proteins. In addition, M13 follows a simpler infection cycle than  $\lambda$ , and does not need genes for insertion into the host genome.

Injection of an M13 DNA molecule into an *E. coli* cell occurs via the pilus, the structure that connects two cells during sexual conjugation. Once inside the cell the single-stranded molecule acts as the template for synthesis of a complementary strand, resulting in normal double-stranded DNA. This molecule is not inserted into the bacterial genome, but instead replicates until over 100 copies are present in the cell. When the bacterium divides, each daughter cell receives copies of the phage genome, which continues to replicate, thereby maintaining its overall numbers per cell. New phage particles are continuously assembled and released, about 1000 new phages being produced during each generation of an infected cell.

Several features of M13 make this phage attractive as a cloning vector. The genome is less than 10 kb in size, well within the range desirable for a potential

vector. In addition, the double-stranded replicative form (RF) of the M13 genome behaves very much like a plasmid, and can be treated as such for experimental purposes. It is easily prepared from a culture of infected *E. coli* cells and can be reintroduced by transfection. Most importantly, genes cloned with an M13-based vector can be obtained in the form of single-stranded DNA. Single-stranded versions of cloned genes are useful for several techniques, notably DNA sequencing and *in vitro* mutagenesis. Cloning in an M13 vector is an easy and reliable way of obtaining single-stranded DNA for this type of work. M13 vectors are also used in phage display, a technique for identifying pairs of genes whose protein products interact with one another.

### 11.6.3 Cosmids

The final and most sophisticated type of  $\lambda$ -based vector is the cosmid. Cosmids were first developed in 1978 by Barbara Hohn and John Collins. Cosmids are hybrids between a phage DNA molecule and a bacterial plasmid. The first part of their name, “cos” comes from the fact that cosmid contains the cohesive ends, or cos site of normal. These ends are essential for packaging the DNA into phage heads. The last part of their name “mid” indicates that cosmid carry a plasmid origin of replication like the one found in the PBR322 plasmid. The design of cosmids centers on the fact that the enzymes that package the  $\lambda$  DNA molecule into the phage protein coat need only the cos sites in order to function. The *in vitro* packaging reaction works not only with  $\lambda$  genomes, but also with any molecule that carries cos sites separated by 37–52 kb of DNA.

A cosmid is basically a plasmid that contain phage cos site. Cosmids contain a plasmids origin of replication and selectable marker such as the ampicillin resistance gene as cosmids lack all the  $\lambda$  genes and so do not produce plaques. Instead colonies are formed on selective media, just as with a plasmid vector.

They also possess a unique restriction enzyme recognition site into which DNA fragments can be ligated. After the packaging reaction has occurred, the newly formed particles are used to infect *E. coli* cells. The DNA is injected into the bacterium like normal DNA and circularizes through complementation of the cos ends. The circularized DNA will, however, be maintained in the *E. coli* as a plasmid. Therefore selection of transformants is made on the basis of antibiotic resistance and bacterial colonies (rather than plaque) will form that contain the recombinant cosmid.

With a cosmid vector of 5kb, we demand the insetion of 32-47 kb of foreign DNA which is much more than a phage vector can accommodate. In order to

clone foreign DNA into cosmid vector, cosmid DNA is first made to linearise by cutting it with appropriate restriction enzyme. Then it is treated with the calf intestine phosphate to remove phosphate group (5') at its ends so as to prevent recircularization of cosmid DNA. Advantage of using cosmid vector is that larger DNA can be cloned than what is possible with phage or plasmid. As larger inserts are possible, genomic library can be created which is composed of fewer clones to be screened. Efficiency of cosmid is high enough to produce a complete genomic library of  $10^6 - 10^7$  clones from a mere  $1\mu\text{g}$  of insert. Genomic libraries of *Drosophila*, mouse and several other organisms have been produced with cosmid vectors.

#### **11.6.4 Phagemids (Hybrid plasmid–M13 vectors)**

Although M13 vectors are very useful for the production of single-stranded versions of cloned genes, they do suffer from one disadvantage. There is a limit to the size of DNA fragment that can be cloned with an M13 vector, with 1500 bp generally being looked on as the maximum capacity, though fragments up to 3 kb have occasionally been cloned. To get around this problem a number of hybrid vectors (“phagemids”) have been developed by combining a part of the M13 genome with plasmid DNA.

An example is provided by pEMBL8, which was made by transferring into pUC8 a 1300 bp fragment of the M13 genome. This piece of M13 DNA contains the signal sequence recognized by the enzymes that convert the normal double-stranded M13 molecule into single-stranded DNA before secretion of new phage particles. This signal sequence is still functional even though detached from the rest of the M13 genome, so pEMBL8 molecules are also converted into single-stranded DNA and secreted as defective phage particles. All that is necessary is that the *E. coli* cells used as hosts for a pEMBL8 cloning experiment are subsequently infected with normal M13 to act as a helper phage, providing the necessary replicative enzymes and phage coat proteins. pEMBL8, being derived from pUC8, has the polylinker cloning sites within the *lacZ'* gene, so recombinant plaques can be identified in the standard way on agar containing X-gal. With pEMBL8, single-stranded versions of cloned DNA fragments up to 10 kb in length can be obtained, greatly extending the range of the M13 cloning system.

#### **11.6.5 BAC**

Bacterial artificial chromosomes (BACs) are engineered version of F plasmids. They are capable of carrying approximately 200 kbp of inserted DNA

sequence. The F-factor origin of replication (OriS) maintains their level at approximately one copy per cell. In addition to OriS, BACs contain four factor genes required for replication and maintenance of copy number, repE, parA, parB and parC. In addition to the F-factor genes, pBeloBac11 also contain a selectable antibiotic resistance marker (CAMR) and lacZ1 gene harbouring a multiple cloning site for the blue-white screening of BACs containing inserts. Additionally, the BAC contains a cos site (cosN) and loxPsite. These sites are used for specific cleavage of the insert containing BAC during restriction mapping. The cosN site be cleaved using terminase, while the lox P site can be cleaved by the Cre protein in the presence of an oligonucleotide to the loxP sequence. The first BAC vector, PBAC108L lacked a selectable marker for recombinants. Thus clones with inserts had to be identified by colony hybridization. Two widely used BAC vectors PBeloBAC11 and PECBAC1 are derivatives of PBAC108L.

BACs are often used to sequence the genome of organisms in genome projects, for example the Human Genome Project. A short piece of the organism's DNA is amplified as an insert in BACs, and then sequenced. Finally, the sequenced parts are rearranged in silico, resulting in the genomic sequence of the organism.

BACs are capable of maintaining human and plant genomic fragments of greater than 300kb for over 100 generation with high degree of stability. They have lower level of chimerism. They are now being utilized to a greater extent in modeling genetic diseases, often alongside transgenic mice. BACs have been useful in this field as complex genes, may have several regulatory sequences upstream of the encoding sequence, including various promoter sequences that will govern a gene's expression level. The above vectors have been used to some degree of success with mice when studying neurological diseases such as Alzheimer's disease or as in the case of aneuploidy associated with Down syndrome. There have also been instances when they have been used to study specific oncogenes associated with cancers. BACs can also be utilized to detect genes or large sequences of interest and then used to map them onto the human chromosome using BAC arrays. They are preferred for these kinds of genetic studies because they accommodate much larger sequences without the risk of rearrangement, and are therefore more stable than other types of cloning vectors.

### **11.6.6 YAC**

Yeast artificial chromosome (YAC) vectors allow the cloning, within yeast cells, of fragments of foreign genomic DNA that can approach 500kbp in size. These vectors contains several elements of typical yeast chromosomes including a yeast centromere (CEN ), yeast autonomously replicating 4 sequence (ARSI), yeast telomere (TEL), genes for YAC selection in yeast, bacterial replicating origin and a bacterial selectable marker.

CEN is specified by a 125 bp DNA segment. 4 The consensus sequence consist of three elements that is a 78-86 bp region with more than 90% AT residues, flanked by a conserved sequence on one side and a short consensus sequence on the other. Yeast ARS elements are essentially origin of replication that function in yeast cells autonomously.

Telomeres are the specific sequences that is 51-TGTGGGTGTGGTG-31 that are present at the end of the chromosomes in multiple copies and are necessary for replication and chromosome maintenance. The vector has a functional copy of URA3, a gene involved in uracil biosynthesis, and also a TRP1, a gene involved in tryptophan biosynthesis, that allow selection of yeast cells that have taken up the vector.

Yeast expression vectors, such as YACs, YIps (yeast integrating plasmid), and YEps (yeast episomal plasmid), are extremely useful because one can get eukaryotic protein products with posttranslational modifications as yeasts are themselves eukaryotic cells. However, YACs have been found to be more unstable than BACs, producing chimeric effects. Before the advent of the Human Genome Project, YACs and BACs were used to map sections of DNA of interest when hunting for specific genes. Inserts as large as 1000kb can be cloned into YAC vectors.

### **11.6.7 PACs**

To overcome some of the problems associated with cosmid or YAC systems, a method for cloning and packaging DNA fragments using a bacteriophage PI system has been developed that offers the ability to clone large genomic DNA fragments of between 70-95 kbp in size. PI bacteriophage has a much larger genome than phage (110-115bp).

Vectors have been designed with the essential replication components of PI incorporated into plasmid. Upon infecting E.coli, bacteriophage PI may either express lytic functions, producing 100-200 new bacteriophage particles and lysing the infected bacterium. PI phage has two replication regions that is one

to control lytic DNA replication and other to maintain the plasmid during non-lytic growth. Phage PI uses a 'head full' packaging strategy and can accommodate a total DNA length of approximately 110-115kbp.

#### **11.6.8 Expression vectors**

Expression vectors are vectors that allow one to construct gene fusions that replace native promoter of a gene with another promoter. Expression vectors allow the expression of cloned gene, to give the product (protein). This can be achieved through the use of promoters and expression cassettes and regulatory genes (sequences). These vectors are used for transformation to generate transgenic plants, animals or microbes where cloned gene expressed to give the product. Commercial production of cloned gene may also be achieved by high expression using these vectors. The essential features of expression vector are summarized in the Table 8. For expression of cloned gene in plants or animals only plant specific or animals specific promoters work. Expression vectors may be used to isolate specific cDNAs. They are required if one wants to prepare RNA probes from the cloned genes or to purify large amount of gene products. Several expression vectors are available to the sacchromyces researcher and can be obtained from colleagues or from commercial sources. The ADH1 promoter is commonly used for high level constitutive expression in glucosegrown cells. GAL1 and GAL10 are induced to very high level in galactose grown cells but expression is dramatically repressed by growth on glucose. An expression system developed by Mumberg et al. (1995) allows the constitutive production of a gene product over a 1000 fold range

#### **11.6.9 Shuttle vectors**

Shuttle vector is that which can replicate in the cells of more than one organism. Transfer of genes between unrelated species is one of the requirements of biotechnology. Broad host range vector exist in gram negative bacteria and Streptomyces naturally. A shuttle vector however may be required having necessary replicon for maintenance in different combinations in unrelated hosts. These vectors have great importance in the genetic manipulations of industrially important species. Shuttle vectors can exploit gene manipulation procedures of different hosts. Now a days the above vector which function in a given set of species or host are commercially available. For example, one type of shuttle vector is used to clone the genes in E.coli and yeast and another type of shuttle vector is used for E.coli and animal cells, eg SV40 plasmid vector. The first shuttle vector that became popular and

introduced the idea of such interchangeable vectors is the one that could be used in both *E.coli* and yeast (*Sacchromyces cerevisiae*). It contains ori of both species and a number of marker each for the two hosts. A cloning site is of course provided.

#### **11.6.10 Vectors for cloning in higher plants**

Research is going on for availability of suitable vectors for cloning in plant cells. Vector system should permit, gene cloning in organisms such as *E. coli* so that the recombinant molecules can be readily constructed and manipulated into these hosts prior to introduction into host plant cells. Genetic vehicles may be derived from naturally occurring plant vectors such as Ti (tumor inducing) and Ri (root inducing) plasmids of *Agrobacterium*, plant viruses or viroids or artificial vectors (developed by utilizing components of plant genome).

##### **11.6.10.1 Ti Plasmids**

Ti plasmids are large, circular double stranded DNA molecules of about 200kb, and like other bacterial plasmids, exists in *Agrobacterium* cells as independently replicating genetic units. Ti plasmids are maintained in *Agrobacterium* because a part of the plasmid DNA, called T-DNA carries the genes coding for the synthesis of unusual amino acids called opines. T-DNA (15-30kb) is transferred to the plant cells during infection and becomes integrated into plant nuclear DNA, where it is expressed. It is responsible for induction and maintenance of the tumorous state and opines synthesis in the plant cell. Vir genes of Ti plasmid are required for mobilization of DNA from bacterium to plant cell. Features of Ti plasmid which make them attractive gene vectors are listed in the Table 9. ATi plasmid mutant was made in which all the on-cogenic functions of the T-DNA have been removed and replaced by pBR322. This Ti plasmid, pGV3850, still mediates efficient transfer and stabilization of its truncated T-DNA into infected plant cells. In addition to this, integration and expression of this minimal TDNA in plant cells does not interfere with normal plant cell differentiation. A DNA fragment cloned in a pBR vector can be introduced in the pGV3850 T-region upon a single recombination event through the pBR322 region of pGV3850 producing a cointegrate useful for the transformation of plant cells. Based upon these properties, pGV3850 is proposed as an extremely versatile vector for the introduction of any foreign DNA of interest into plant cells.



### **1.6.10.2 Ri Plasmids**

Ri plasmids of *Agrobacterium rhizogenes* which is causative agent of hairy root disease may also provide effective vectors. Host range of *Agrobacterium* genes is smaller than that of *Agrobacterium tumefaciens*. Ri plasmids are around 150kb in size. T-DNA of Ri plasmid is incorporated stably into genome of plant cell. It is technically easier to regenerate whole plants from hairy roots than from *Agrobacterium tumefaciens* transformed tissues. Vectors based Ri plasmids can be used for gene manipulation. The Ri TDNA region can be used for the construction of plant transformation vectors similar to the Ti-plasmid derived vectors.

### **11.6.11 Vectors for animal cells**

Considerable effort has been put into the development of vector systems for cloning genes in animal cells. These vectors are needed in biotechnology for the synthesis of recombinant protein from genes that are not expressed correctly when cloned in *E. coli* or yeast, and methods for cloning in humans are being sought by clinical molecular biologists attempting to devise techniques for gene therapy, in which a disease is treated by introduction of a cloned gene into the patient.

Replicons analogous to bacterial plasmids are not found in animal cells. Some viruses are used to develop the vectors for animal cells. Plasmids bearing the Epstein-Barr virus nuclear antigen (EBNA-1) and origin of replication (oriP) can be maintained within some primates and canine cell lines but not in rodents cell lines. The process of DNA uptake may be either transient or stable.

#### **11.6.11.1 Viruses as cloning vector**

##### **SV40**

The first mammalian cell viral vector to be developed was based on the simian virus 40 (SV40) (Figure 2.3). SV40 is a primate double stranded DNA tumor virus whose genome is 5243 bp in size. Genes are encoded on both strands of the genome such that they overlap each other. The “early” genes, expressed early in the infection cycle and coding for proteins involved in viral DNA replication, and the “late” genes, coding for viral capsid proteins. This virus is capable of infecting several mammalian species, following a lytic cycle in some hosts and a lysogenic cycle in others. Virus has two life cycles depending upon host cell line employed. In permissive cells (Monkey cells) a productive lytic cycle occurs while in non permissive (rat or mouse cells) viral replication is blocked and host cells are transformed (no growth as monolayer but proliferate

without substratum attachment). Recombinant SV40 vectors (rSV40) are good candidates for gene transfer, as they display some unique features: SV40 is a well-known virus, non replicative vectors are easy-to -make, and can be produced in titers of 10(12) IU/ml. They also efficiently transduce both resting and dividing cells, deliver persistent transgene expression to a wide range of cell types, and are non-immunogenic.

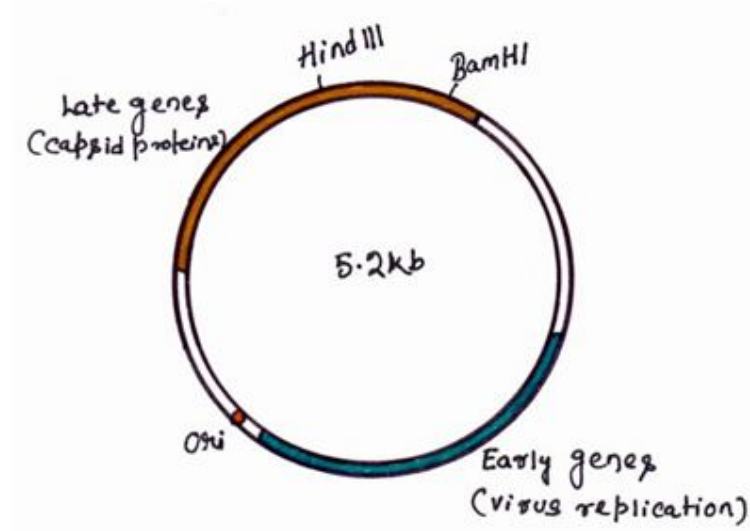

**Figure 2.3 SV40**

Present disadvantages of rSV40 vectors for gene therapy are a small cloning capacity and the possible risks related to random integration of the viral genome into the host genome. Cloning with SV40 therefore involves replacing one or more of the existing genes with the DNA to be cloned. In the years since 1979, a number of other types of virus have been used to clone genes in mammals. These include:

### **Adenovirus**

Adenovirus has 35 kb linear genome. Variants containing single cloning site and accommodating only 5% extra DNA can be used as vectors and can be propagated alone. If viral genes are deleted then recombinant vector can be propagated in helper cell lines only. Adenovirus enables DNA fragments of up to 8 kb to be cloned, longer than is possible with an SV40 vector. Adenovirus can be used as vector for stable and transient expression. This virus bearing foreign DNA can be used to produce the foreign protein in many different cell types, but gene expression is usually transient because the viral DNA does not integrate into the host genome. The lack of integration may, however, be advantageous if adenoviral vectors are used in gene therapy. Most vectors

derived from the adenoviral genome are replication deficient. Adenoviral vectors are useful because they are highly efficient at getting DNA into cells. They are capable of containing DNA inserts upto about 8kbp in size and can infect both replicating and differentiating cells. Additionally, since they do not integrate into the host genome, they cannot bring about mutagenic effects caused by random integration events. The disadvantage of adenoviral vector is that expression is transient since the viral DNA does not integrate into the host. These vectors are based on an extremely common human pathogen and in vivo delivery may be hampered by prior host immune response to one type of virus. They are more difficult to handle because their genomes are bigger.

### **Papillomaviruses**

Papillomaviruses, which also have a relatively high capacity for inserted DNA. Bovine papilloma virus, which causes warts on cattle, is of interest because it has an unusual infection cycle in mouse cells, taking the form of a multicopy plasmid with about 100 molecules present per cell. It does not cause the death of the mouse cell, and BPV molecules are passed to daughter cells on cell division, giving rise to a permanently transformed cell line. BPV genome can be maintained extra-chromosomally (at 20-200 copies per cell) in transformed or tumour cells. Bovine papilloma virus (BPV-1) DNA replicates exclusively as an extrachromosomal molecule in virally induced tumors as well as in transformed mouse fibroblasts in culture. The complete viral genome or a 69% HindIII BamHI fragment thereof have been used as vectors to introduce cloned prokaryotic or eukaryotic genes into mammalian cells in culture. These recombinant molecules replicate as multicopy plasmids in stably transformed cells. This suggests that a broad potential exists for BPV-1 DNA derived vectors. Shuttle vectors consisting of BPV and E. coli sequences, and capable of replication in both mouse and bacterial cells, have been used for the production of recombinant proteins in mouse cell line.

### **Adeno-associated virus (AAV)**

Adeno-associated virus (AAV), which is unrelated to adenovirus but often found in the same infected tissues, because AAV makes use of some of the proteins synthesized by adenovirus in order to complete its replication cycle. In the absence of this helper virus, the AAV genome inserts into its host's DNA. With most integrative viruses this is a random event, but AAV has the unusual property of always inserting at the same position, within human chromosome 19. Knowing exactly where the cloned gene will be in the host genome is

important if the outcome of the cloning experiment must be checked rigorously, as is the case in applications such as gene therapy. AAV vectors are therefore looked on as having major potential in this area.

### **Retroviruses**

Retroviruses, which are the most commonly-used vectors for gene therapy. Although they insert at random positions, the resulting integrants are very stable, which means that the therapeutic effects of the cloned gene will persist for some time.

### **Pox viral vectors**

Pox viruses such as vaccinia, have a very large DNA genome (187kb) and can accommodate large inserts of up to 35kb. No helper virus is required for propagation. A variety of foreign genes have been cloned in vaccinia including HT LVIII envelope protein, hepatitis B virus surface antigen, influenza virus, hemagglutinin, rabies virus glycoprotein etc. Vaccine production is being investigated using such expression.

---

## **11.7 Somatic Hybridization**

---

Plant protoplasts represent the finest single cell system and offer exciting possibilities in the fields of somatic cell genetics and crop improvement. Isolated protoplasts serve as an excellent starting material for cell cloning and development of mutant lines in vitro than single whole cells. They also provide experimental material for many other fundamental and applied studies. Freshly isolated protoplasts have been employed in studies related to cell wall synthesis, membrane properties and virus infection. However, the feature of isolated protoplasts that has brought them into the limelight is the ability of these naked cells to fuse with each other irrespective of their origin.

Protoplast fusion has opened up a novel approach to raising new hybrids. This technique of hybrid production through the fusion of body cells, bypassing sex altogether, is called somatic hybridization.

Unlike sexual reproduction in which organelle genomes are generally contributed by the maternal parent, somatic hybridization also combines cytoplasmic organelles from both the parents. In somatic hybrids recombination of mitochondrial genomes occurs frequently. Chloroplast genome recombination is rare but segregation of chloroplast of the two sources in hybrids causes selective elimination of chloroplasts of one or the other parent, forming novel nuclear-cytoplasmic combinations. Fusion products with the

nucleus of one parent and extra-nuclear genome/s of the other parent are referred to as cybrid and the process to obtain cells or plants with such genetic combination/s is called cybridization. Somatic cell fusion, thus offers new ground to achieve novel genetic changes in plants.

The technique of somatic hybridisation involves the following steps.

**(i) Isolation of protoplasts:**

Plant cell consist of cell wall which has to be degraded if the protoplasts of the cell has to be obtained to be manipulated as required. For this purpose, the plant cell is treated with enzyme like pectinase, macerozyme, and cellulase etc., which hydrolysis the plant cell wall. The conditions are altered so that successful release of protoplast is aided. The osmotic pressure of the solution is controlled by addition of calcium chloride salts into it. This improves the plasma membrane activity. Since protoplasts are present in every plant cell it can be theoretically isolated from all the parts of plant. But most successful isolation was made possible from leaf of the plants. The leaf is surface sterilized and lower epidermis is removed, and treated with enzyme solution.

**(ii) Protoplast Fusion**

During enzymatic degradation of cell walls some of the adjacent protoplasts fuse together forming homokaryons (also referred to as homokaryocytes, each with two to several nuclei). This type of protoplast fusion, called 'spontaneous fusion', has been ascribed to the expansion and subsequent coalescence of the plasmodesmatal connections between the cells. The occurrence of multinucleate fusion bodies is more frequent when protoplasts are prepared from actively dividing cultured cells. About 50% of the protoplasts prepared from callus cells of maize endosperm and suspension cultures of maize embryos were multinucleate. A sequential method of protoplast isolation, or exposing the cells to strong plasmolyticum solution before treating them with mixed enzyme solution would sever the plasmodesmatal connection and, consequently, reduce the frequency of spontaneous fusion.

So far as somatic hybridization and cybridization are concerned spontaneous fusion is of no value; these require the fusion of protoplasts of different origin. To achieve induced fusion a suitable chemical agent (fusogen) or electric stimulus is generally necessary. Since 1970 a variety of fusogens have been tried to fuse plant protoplasts of which  $\text{NaNO}_3$ , high pH and high  $\text{Ca}^{2+}$ , and polyethylene glycol treatments have been successfully used to produce somatic

hybrid/cybrid plants. During the last decade fusion of protoplasts by electric stimulus (electrfusion) has gained increasing popularity.

### **Chemical fusion**

#### **(i) NaNO<sub>3</sub> treatment:**

Equal densities of protoplasts from two different sources are mixed and then centrifuged at 100g for 5 minutes to get a dense pellet. This is followed by addition of 4 ml of 5.5% sodium nitrate in 10.2% sucrose solution to Resuspend the protoplast pellet. The suspended protoplasts are kept in water – bath at 35 0C for 5 minutes and again centrifuged at 200 g for 5 minutes. The pellet is once again kept in water bath at 30 0C for 30 minutes. The fusions of protoplast take place at the time of incubation. Finally, the protoplasts are plated in semisolid culture medium. The frequency of fusion is not very high in this method.

Induced fusion by NaNO<sub>3</sub> was first demonstrated by Power et al (1970). Isolated protoplasts were cleaned by floating in sucrose osmoticum. Transfer of the protoplasts in 0.25M NaNO<sub>3</sub> solution and subsequent centrifugation promoted the fusion process. This procedure results in a low frequency of heterokaryon formation and protoplasts are markedly altered in their uptake capabilities.

#### **(ii) High pH and high Ca<sup>++</sup> Treatment:**

Kelner and Melchers (1973) developed a method to effectively induce fusion of tobacco protoplasts at a high temperature (37°C) in media containing high concentration of Ca<sup>++</sup> ions at a highly alkaline condition (pH 10.5). Equal densities of protoplasts are taken in centrifuge tube and protoplasts are spun at 100 g for 5 minutes. The pellet is suspended in 0.5 ml of medium. 4 ml of 0.05 M CaCl<sub>2</sub>, 2H<sub>2</sub>O in 0.4 M mannitol at PH 10.5 is mixed to the protoplast suspension. The centrifuge tube containing protoplast at high PH or Ca<sup>++</sup> is placed in water bath at 30 0C for 10 minutes and is spun at 50 g for 3 to 4 minutes. This followed by keeping the tubes in water bath (37°C) for 40- 50 minutes. About 20-30% protoplast are involved in this fusion experiment.

This method was developed by Keller and Melchers (1973) for fusing two different lines of tobacco protoplasts. Isolated protoplasts are incubated in a solution of 0.4M mannitol containing 0.05M CaCl<sub>2</sub>, with pH at 10.5 (0.05 M glycine – NaOH buffer) and temperature 37°C. Aggregation of protoplasts generally takes place at once and fusion occurs within 10min. Many

intraspecific and interspecific somatic hybrids have been produced using this procedure.

**(iii) Polyethylene glycol treatment:**

PEG has been used as a fusogen in a number of plant species because of the reproducible high frequency of heterokaryon formation. About 0.6ml of PEG solution is added in drops to a pellet of protoplasts in the tube. After having capped the tube, protoplasts in PEG are incubated at room temperature for 40min. Occasional rocking of tubes helps to bring the protoplasts in contact. This is followed by elution of PEG by the addition of 0.5-1 ml of protoplast culture medium in the tube after every 10min. Preparations are now washed free of fusogen by centrifugation and the protoplasts resuspend in the culture medium. After treatment with fusogen, protoplasts are cultured following the standard procedures. PEG either provides a bridge by which  $Ca^{++}$  can bind membrane surfaces together or leads to a disturbance in the surface charge during the elution process.

PEG induces protoplast aggregation and subsequent fusion. But the concentration and molecular weight of PEG are important with respect to fusion. A solution of 37.5% w/v PEG of molecular weight 1500 to 6000 aggregates mesophyll and cultured cell protoplasts during a 45 minutes incubation at room temperature. Fusion of protoplast takes place during slow elution of PEG with liquid culture medium. Carrot protoplast can be fused by 28% PEG 1500 and fusion can be promoted by  $Ca^{++}$  ion at concentration of 3.5 mM. But higher concentration of  $Ca^{++}$  ion has been considered beneficial. In some studies, high PH/ $Ca^{++}$  and PEG method have been combined.

**(iv) Electrofusion:**

Recently, mild electrical stimulation is being used to fuse protoplasts. This technique is known as electrofusion of protoplasts. Two glass capillary microelectrode are placed in contact with the protoplasts. An electric field of low strength ( $10kv\ m^{-3}$ ) give rise to dielectrophoretic pole generation within the protoplast suspension. This lead to pearl chain arrangement of protoplasts. The number of protoplasts within a pearl chain depends upon the population density of the protoplast and the distance between the electrodes. Subsequent application of high intensity electric impulse ( $100kv\ m^{-3}$ ) for some microseconds results in the electric breakdown of membrane and subsequent fusion.

## Selection

After the protoplast fusion, heterokaryons (a cell formed by fusion of two or more protoplasts of different species and the cell contains individual nucleus from both the species) have to be selected from the protoplast population that comprises of homokaryons and heterokaryons.

One such approach used for the selection of heterokaryons involves the culturing of hybrids on such a medium that favors the growth of hybrids and restricts the growth of parent cells.

Another approach involves the selection of hybrids in the form of green callus (this approach was used for selection of *Datura* hybrids). Staining the protoplasts with fluorescent dyes of different colors such as red and green allows easy visual selection of hybrid varieties.

Some researchers have used selectable antibiotic or herbicide-resistant markers to identify the hybrid cell. Another powerful approach involves the culturing of the entire protoplast population on a suitable growth medium (devoid of any selection marker) under appropriate environmental condition followed by identification of hybrid calli based on protein banding patterns, chromosome constitution, etc.

---

## 11.8 Summary

---

After going through this unit you have understood:

What is biotechnology? How it is helpful in production of various products of utility for mankind using various techniques including genetic engineering, basics of genetic engineering. What is a recombinant DNA? How gene cloning is done? Vectors are the vehicles used for cloning and their various types. For the purpose of cloning and culturing of bacteria various media are required and their categorization is necessary to know the type of media required for microbial growth. Different techniques used for propagation of microbes. How genetic engineering can be done with plants.

---

## 11.9 Self-Learning Exercise

---

### Section-A (Very Short type)

1. Plasmid integrated in bacterial chromosome is called \_\_\_\_\_.
2. An example of plasmid is \_\_\_\_\_.
3. M13 is a \_\_\_\_\_ bacteriophage.
4. A cell without cell wall is \_\_\_\_\_.



5. A medium with known composition of constituents is called as \_\_\_\_\_.
6. Ti plasmid is derived from \_\_\_\_\_.
7. Ri plasmid is a root hair inducing plasmid. (T/F)
8. Phagemid is a hybrid-M13 plasmid. (T/F)
9. Nutrient agar is a basal media. (T/F)
10. Blood agar is a synthetic media. (T/F)

#### **Section-B (Short Answer type)**

1. Name three *E. coli* plasmid?
2. What is synthetic media? Give an example.
3. What is copy number?
4. Mention four steps of gene cloning.
5. Define cosmid.
6. Draw the diagram of bacteriophage.
7. What is biotechnology?
8. What are restriction enzymes?
9. Nomenclature of plasmids.
10. What is a replacement vector?

#### **Section-C (Long Answer type)**

1. Give a detailed note on types of media used for microbial culture.
2. Give an introductory idea about genetic engineering.
3. Write a detailed note on pour plate method and draw neat and labeled diagram.
4. Write short notes on: (a) Expression vector (b) Shuttle vector
5. Give a detailed note on any two viruses used as animal cloning vector.
6. Describe somatic hybridization.
7. Give a detailed note on plasmids.
8. Give a detailed note on bacteriophage.

#### **Answer Key of Section-A**

1. Episome.
2. pBR322.
3. Filamentous.
4. Protoplast.
5. Defined media.
6. *Agrobacterium tumefaciens*.
7. T

8. T

9. T

10. F

---

## **11.10 References**

---

- Gene cloning by T.A. Brown
- An Introduction to Genetic Engineering by Desmond S. T. Nicholl
- Foundations in Microbiology by Dr. Ulhas Patil
- Introduction to Plant Biotechnology by H.S. Chawla

## Unit - 12

---

# Recombinant DNA Technology

---

### Structure of the Unit

- 12.0 Objectives
- 12.1 Introduction
  - 12.1.1 'Steps involved in RDT
  - 12.1.1 Isolating DNA
- 12.2 Cutting DNA
  - 12.2.1 Joining DNA
  - 12.2.2 Amplifying the recombinant DNA
- 12.3 Vectors
  - 12.3.1 Requirements for a cloning vector
  - 12.3.2 Types of Vectors
- 12.4 Advantages of RDT
- 12.5 Disadvantages of RDT
- 12.6 Isolation of Genetic Material
  - 12.6.1 Isolation of DNA for interest
  - 12.6.2 DNA Isolation Methods
    - 12.6.2.1 Preparation of crude lysates
    - 12.6.2.2 Salting-out methods
    - 12.6.2.3 Organic extraction methods
    - 12.6.2.4 Cesium chloride density gradients
    - 12.6.2.5 Fragmentation by Mechanical Shearing
    - 12.6.2.6 Short-Gun method
    - 12.6.2.7 cDNA method
- 12.7 Gel Electrophoresis
- 12.8 Amplification by PCR
  - 12.8.1 Methodology of PCR
  - 12.8.2 Characterization of PCR-Products
  - 12.8.3 Applications of PCR
  - 12.8.4 Limitations of PCR
- 12.9 DNA Sequencing
- 12.10 Insertion of Recombinant DNA into Host Cells.

12.10.1	Bacterial Transformation
12.10.2	Bacterial Conjugation
12.10.3	Bacterial Transduction
12.10.4	Mammalian Cell Transfection
12.11	Summary
12.12	Glossary
12.13	Self-Learning Exercise
12.14	References

---

## **12.0 Objectives**

---

After going through this unit you will be able to understand

- Major steps involved in RDT
- Different types of cloning vectors involved in RDT
- Advantages and Disadvantages of RDT
- Isolation of Genetic Materials through different Isolation Techniques
- Separation of genetic materials through Gel Electrophoresis Techniques
- Amplification of DNA through Polymerase Chain Reaction
- DNA Sequencing
- Insertion of Recombinant DNA into Host Cells

---

## **12.1 Introduction**

---

Recombinant DNA refers to the manipulation of genetic makeup of living cells by inserting desired genes through a DNA vector. In 1973, Stanley Cohen and Herbert Boyer deigned a protocol for transferring certain genes from one organism to another. The DNA formed by joining of two different segments of different DNA is known as recombinant DNA or chimeric DNA. The organism whose genetic makeup has been changed using genetic engineering is called as recombinant organism or chimera.

Recombinant Technology has many applications in -:

- **Agriculture:** Insect Resistant crop plant, Virus resistant plant, Herbicides resistant plant, Plant with attractive flower colour, Nitrogen fixing plants etc.
- **Health:** Human Insulin in bacteria, Edible Vaccines, Monoclonal Antibody, Interferons etc.
- **Transgenic Animal:** Transgenic cattle, transgenic pig, transgenic sheep etc.

The advances in recombinant DNA technology have occurred in parallel with the development of genetic processes and biological variations. The enlargement of new technologies have resulted into production of large amount of biochemically defined proteins of medical importance and created an enormous potential for pharmaceutical industries. The biochemically derived therapeutics is large extra cellular proteins for use in either chronic replacement therapies or for the treatment of life threatening indications.

In today's world of DNA analysis, finding suitable DNA isolation system to satisfy downstream applications needs having great importance as it is vital for the successful completion of experiments. Simply, DNA Extraction is the removal of deoxyribonucleic acid (DNA) from the cells or viruses in which it normally resides. Once the DNA was extracted it should be separated on the basis of their molecular weight. In the early days of DNA manipulation, DNA fragments were laboriously separated by gravity. In the 1970s, the powerful tool of DNA gel electrophoresis was developed. This process uses electricity to separate DNA fragments by size as they migrate through a gel matrix. Specific DNA sequence meant to be amplified for several other genetic applications such as sequencing, RFLP analysis and microsatellite analysis. So technique like Polymerase chain reaction (PCR) enables researchers to produce millions of copies of a specific DNA sequence in approximately two hours. This automated process bypasses the need to use bacteria for amplifying DNA.

Regardless of the approach to the genome as a whole, the actual process of DNA sequencing is the same. During DNA sequencing, the bases of a small fragment of DNA are sequentially identified from signals emitted as each fragment is resynthesized from a DNA template strand.

Another successful method to create multiple copies of the gene of interest is the process of insertion of foreign gene and vector is used which is inserted into host for cloning. This method is relatively new procedure which allows analysis

of proteins and other parts of most organisms which had previously been very difficult to study due to scarcity of gene of interest.

---

## **12.2 Steps involved in RDT**

---

Isolate DNA then cutting the DNA with restriction enzymes after that ligate into cloning vector then transform recombinant DNA molecule into host cell so that each transformed cell will divide many, many times to form a colony of millions of cells, each of which carries the recombinant DNA molecule (DNA clone).

- A. Isolation of Desired Gene
- B. Preparation of Vector
- C. Ligation
- D. Introduction of Recombinant DNA into Host cell
- E. Selection of recombinant host cell
- F. Expression of cloned gene

### **12.2.1. Isolation of desired DNA**

For making recombinant organisms, a desired DNA fragment has to be introduced into the host cell, these desired DNAs can be obtain from the total genome of the cell either by restriction digestion (with restriction endonucleases or by mechanical shearing).

The desired gene can be clone is located in the cell DNA of the source organisms along with several genes so firstly, it should be isolated from other genes of the cell DNA. For this purpose two methods are follows to isolate desired DNA from the genome of the cell. They are restriction digestion and mechanical shearing.

#### **DNA Extraction**

1. Preheat 5ml CTAB (add 10 $\mu$ l mercaptoethanol to each 5ml CTAB) in a blue-topped 50ml centrifuge tube at 60-65 $^{\circ}$ C. Remove and discard midribs and wrap laminae in aluminum foil and freeze in liquid nitrogen. 0.5 – 1.0 gm tissue/5ml CTAB  
  
(Can store leaf material after liquid Nitrogen – 1-2 days at –20 $^{\circ}$ C or –80 $^{\circ}$ C for longer periods)
2. Gently crumble leaf tissue over cold pestle of liquid nitrogen. Grind frozen leaves with one spatula of fine sand add 0.5 spatula of PVPP powder after grinding.

3. Scrape powder into dry tube and add pre-heated buffer and mix gently.  
Avoid leaving dry material around rim of tube. Adjust CTAB volume to give a slurry-like consistency, mix occasionally.
4. Incubate for 60 min at 60°C
5. Add equal volume of chloroform/iso-amyl alcohol (24:1), Mix for about 3min, then transfer contents to narrow bore centrifuge tubes. Balance by adding extra chlor/iso. Spin 5,000rpm for 10min (ensure correct tubes used), brake off. (For extra pure DNA isolation - spin and retain supernatant before chloroform extraction).
6. Remove supernatant with wide-bore pastette (cut off blue tip) to clean tube, repeat chloroform extraction once. Supernatant should be clear, though may be coloured.
7. Precipitate DNA with 0.66 vol. of cold isopropanol - can leave overnight. Spool out or spin down DNA, 2min at 2,000rpm.
8. Transfer to 5ml wash buffer for 20min.
9. Dry briefly and resuspend in 1ml T.E. (can be left overnight)
10. Add 1µl 10mg/ml RNase to each 1ml T.E./DNA mixture and incubate for 60min at 37 °C. (If RNase in the sample doesn't matter – stages 11 and 12 may be omitted)
11. Dilute with 2 volumes TE and add 0.3vol 3M Sodium acetate (pH 8) + 2.5 vol. cold 100% ethanol
12. Spool DNA out. Air dry and resuspend in 0.5 to 1ml TE or water (takes time) and freeze until required.

### **12.2.2 Cutting DNA**

#### **Restriction Digestion**

Restriction digestion is the cutting of DNA into fragments by restriction enzymes

The total DNA of an organism is treated with restriction enzymes. These enzymes cut the cell DNA into many fragments; each fragment is differing in their size and molecular weight. These restriction enzymes cut the DNA into blunt end and cohesive end depending upon

The mixture of these DNA fragments is electrophoresed on an agarose gel for a particular time.

By electrophoresis the mixture of this DNA fragments get separated on the basis of their size and molecular weight.

Each DNA fragment obtained from electrophoresis band is cloned into a suitable vector.

**Limitation**

The restriction enzyme may cut the DNA at the middle of desired gene and make it useless.

**Mechanical Shearing**

Genomic DNA is subjected to mechanical forces to cut genomic DNA into small fragments. Sonication with ultrasound cut this DNA randomly with the size of about 300-325 bp.

**Limitations**

Each time it produces new DNA fragments

This method cannot be applied for Eukaryotic organism because of presence of introns.

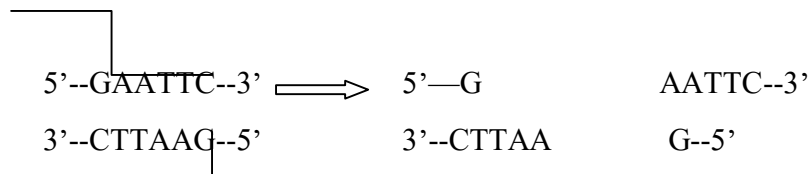

**12.2.3 Joining DNA**

Recombinant DNA is a hybrid DNA formed by joining a desired foreign DNA and a vector DNA, It is indicated by rDNA. The vector DNA and genomic DNA fragments are mixed together. Cohesive end of the vector DNA anneals with genomic DNA fragment by complimentary base pairing and there is nick between these two DNA ends.

This nick is sealed by an enzyme called DNA ligase, It makes the Phosphodiester bond in between these two DNA fragments. Sometimes adapters, linkers and homopolymer tail are also used to join blunt ended DNA molecules.

**12.2.4 Transformation**

The recombinant DNA can be introduced into the host cell by direct transformation and indirect transformation. In direct method, bacterial cell



intake the recombinant DNAs in the medium like microinjection, liposomes, electroporation and particle bombardment method. In indirect method the pathogenic agents such as bacteriophage and *Agrobacterium* pick up the recombinant DNA and introduced it into plant cell.

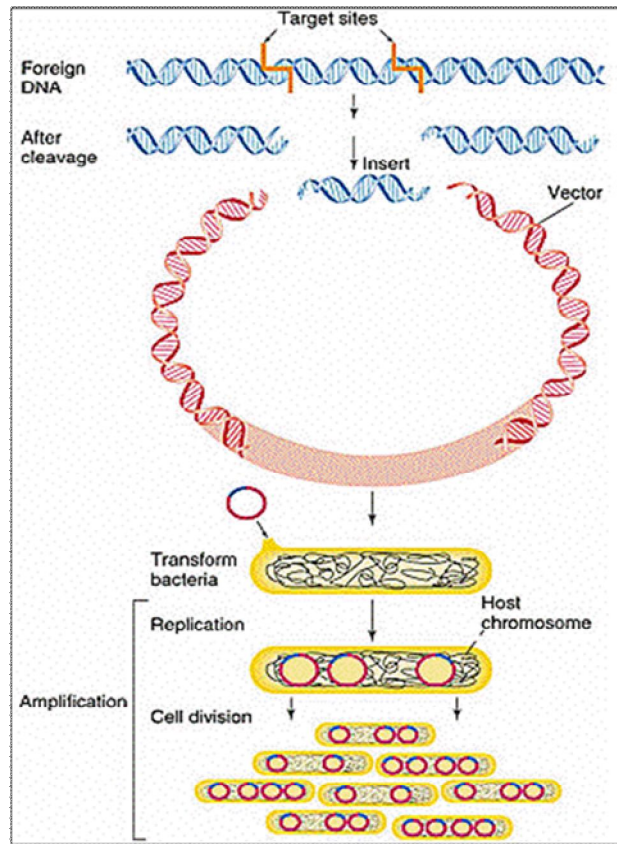

**Figure 1 Steps involved in Recombinant DNA Technology.**

**DNA clone** is a section of DNA that has been inserted into a vector molecule and then replicate in a host cell to form several copies.

---

### 12.3 Vectors

---

The DNA that carries the desired gene to the host cell is called gene cloning vector. It is also known as cloning vector, vector or carrier DNA.

Genetic engineering involves transfer of a desired gene to a host cell that has to be manipulated. The desired may be hydrolyzed by cellular enzymes immediately after introduction further the chance for its expression is also very poor. In order to overcome these problems the desired gene is inserted into a

suitable vector for gene cloning. Plasmids, viral DNAs and cosmids are used as a gene cloning vector.

There are a number of properties that are required to make a good vector:

- Vectors should be self-replicating
- Vectors should be small enough to manipulate outside the cell without breaking
- Vectors should have selectable markers that will allow identification of host cells that have successfully taken the vector into the cell - there should also be a way to screen the vectors to insure the gene that was to be inserted is actually in the vector and that the host cells have not simply taken up re-annealed "blank" vectors.
- Vectors should be protected from degradation by host cell enzymes. Circular plasmids are protected and viral vectors can insert into the host genome quickly to escape degradation.
- Shuttle vectors are plasmids that can exist in several different bacterial species.

### **12.3.1 Requirements for a cloning vector**

- a) Should be capable of replicating in host cell
- b) Should have convenient RE sites for inserting DNA of interest
- c) Should have a selectable marker to indicate which host cells received recombinant DNA molecule
- d) Should be small and easy to isolate

Bacterial **plasmids** are circular double stranded extra chromosomal DNA present in bacterial cell. They have their own origin of replication. Most of the bacteria contain more than one copy of

each plasmid. The number of copies of a plasmid present in a bacterial cell known as copy number. The number of copies varies from 1-40. It could be increased by using antibiotic like chloramphenicol which is an inhibitor of protein synthesis.

### **12.3.2 Types of vectors**

#### **1. *Bacteriophage lambda***

The bacteriophage vector is a bacterial virus that carries a desired gene to a host cell. Viral DNAs are linear or circular and single stranded or double

stranded DNAs. Vector designed from M13 phage, lambda phage are generally used for gene cloning purpose in bacterial cell.

A bacteriophage lambda (45 kb) contains a central region of 15 kb that is not required for replication or formation of progeny phage in *E. coli*. Thus, lambda can be used as a cloning vector by replacing the central 15 kb with 10-15 kb of foreign DNA. This is done as follows: mix RE cut donor DNA and lambda DNA in test tube, a ligate, a use *in vitro* packaging mix that will assemble progeny phage carrying the foreign DNA to infect *E. coli* with the phage to amplify.

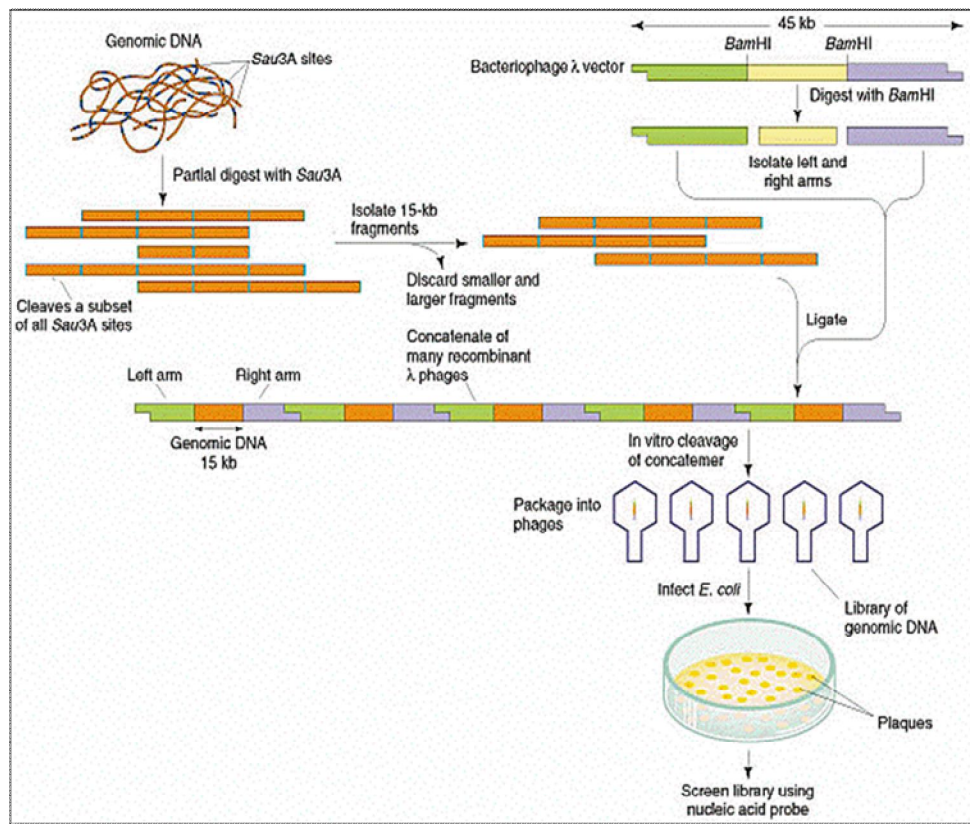
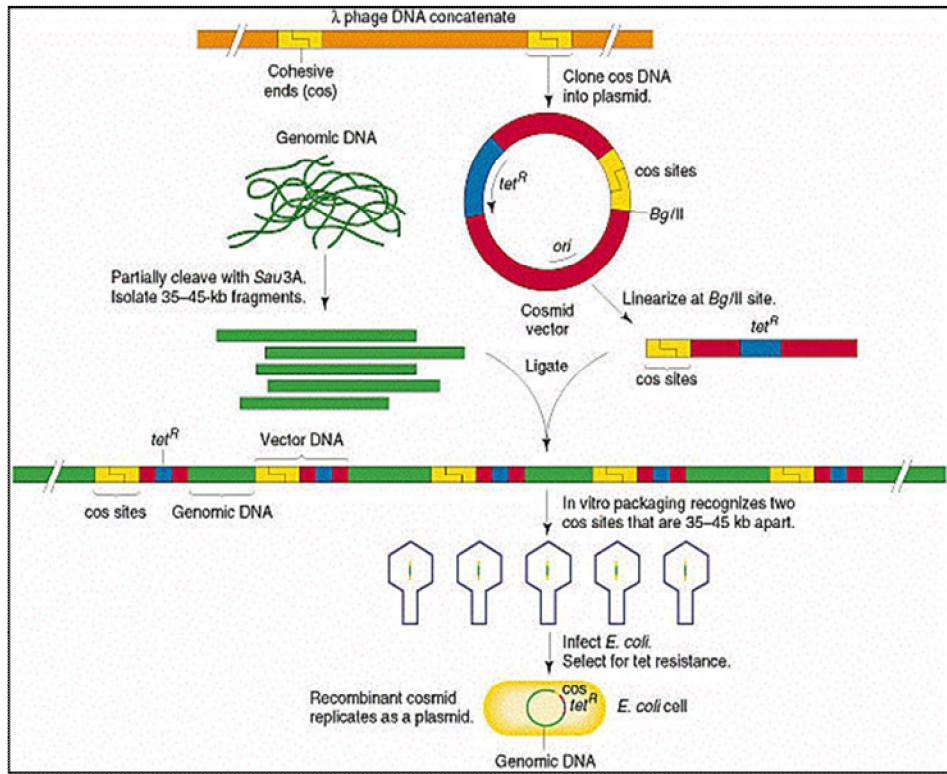

**Figure 2 Amplification of genomic DNA through bacteriophage lambda vector.**

## 2. Cosmids

Cosmids are an artificial plasmid containing cos sites (complimentary single stranded regions) of lambda DNA. It is formed by joining ends of linearized plasmid DNA with cos sites of lambda DNA. So it is a derived vector. It has origin of replication and selectable marker gene from plasmid and cos ends

(complimentary single stranded regions) from lambda phage. Cosmids are hybrids of phages and plasmids that can carry DNA fragments up to 45 kb. They can replicate like plasmids but can be packaged like phage lambda.



**Figure 3 Amplification of genomic DNA through Cosmids.**

### 3. Expression vectors

Expression vectors are vectors that carry host signals that facilitate the transcription and translation of an inserted gene. They are very useful for expressing eukaryotic genes in bacteria.

### 4. Yeast artificial chromosomes (YACS)

Yeast artificial chromosomes (YACS) are derived cloning vector used to clone large DNA fragments in yeast cell. They are linear in shape and they are made up of three regions namely two telomeres, a centromere and an autonomously replicating sequence (ARS). The YAC having all these sequence is called mini chromosome which behaves like an additional chromosome in Yeast. It is used

to form genomic libraries of prokaryotes and eukaryotes and also used in human genome project to construct gene map of chromosomes in man.

They can carry up to 1,000 kb of DNA. Since they are maintained in yeast (a eukaryote), they are useful for cloning eukaryotic genes that contain introns. Also, eukaryotic genes are more easily expressed in a eukaryotic host such as yeast.

#### **5. Bacterial artificial chromosomes (BACs)**

Bacterial artificial chromosomes are bacterial plasmids derived from the F plasmid. They are capable of carrying up to 300 kb of DNA.

#### **6. Plasmids**

Plasmids are small circular DNA molecules found in bacteria. They replicate independently of the bacterial chromosome and depending on the plasmid there may be from 1 to over a hundred copies per cell. If a given plasmid used for cloning is present in a hundred copies, then one can isolate a large amount of cloned DNA from a small number of cells by isolating the plasmid. Plasmids have been developed which contain several features advantageous for cloning. Nearly all plasmids used for cloning have a gene encoding antibiotic resistance. When such a plasmid infects a bacterial cell the

antibiotic resistance is transferred. Only bacteria containing this resistance gene will grow on a media containing the antibiotic. This makes it possible to isolate bacteria that contain the plasmid. Plasmids also contain restriction enzyme sites in specific locations. These sites make it possible to open the circular plasmid and insert foreign DNA. In addition, many plasmids also have differential markers to allow for the identification of recombinant plasmids containing a DNA insert.

---

### **12.4 Advantages of Recombinant DNA Technology**

---

- Provide substantial quantity
- No need for natural or organic factors
- Tailor made product that you can control
- Unlimited utilizations
- Cheap
- Resistant to natural inhibitors

---

## 12.5 Disadvantages of Recombinant DNA Technology

---

- Commercialized and became big source of income for businessmen
- Effects natural immune system of the body
- Can destroy natural ecosystem that relies on organic cycle
- Prone to cause mutation that could have harmful effects
- Major international concern: manufacturing of biological weapons such as botulism & anthrax to target humans with specific genotype
- Concerns of creating super- human race

---

## 12.6 Isolation of Genetic Materials

---

The knowledge of gene isolation was developed after gaining the concept of physical and chemical characteristics of described DNA fragments their sizes, shapes and conformation can aid in the selection of methods used to isolate and purify those segments.

Plants provide several special challenges for researchers interested in the recombinant DNA research. No other class of living organisms has three separate genomes to analyze a nuclear genome containing high molecular weight linear chromosomes, a circular mitochondrial genome, and a circular chloroplast genome. Intact, high molecular weight (>150kbp) plant nuclear gDNA is used to construct genomic DNA libraries and to probe the plant genome for the presence of DNA markers, such randomly amplified polymorphic DNAs (RAPDs) and restriction fragment length polymorphisms (RFLPs). Chloroplast cpDNA and mitochondrial mtDNA, which are thought to incur fewer structural changes over time, are often used to study plant systematic. They are also used to study in vitro synthesis and assembly of organelle proteins.

### 12.6.1 Isolating the DNA (Gene) for interest

For isolation of DNA from linear chromosomes of living organisms like plants, animals or from simple bacteria, it is necessary to break the cell for release of DNA which may be done by physical (homogenization or pressure), or biochemical means like solubilization with detergents or enzymes. The selection of enzyme for this process is dependent on the composition of the

Particular cells that are used for plant materials, for fungal sample, chitinase is used. Lysozyme is commonly used for both bacterial and animal tissue samples. The DNA so obtained is then separated from the cell walls, membranes, and other cellular debris by means of centrifugation, often followed by density gradient centrifugation. The localization of DNAs is the gradient may be done by instrumental method (absorption at 260 nm or visually by means of fluorescence). The isolation of DNA is done by inserting a syringe into the side of the soft plastic centrifuge tube and withdrawing the bands visible in UV radiation. The isolated DNA may be further purified and physically characterized (for example, for size) by means of electrophoresis in gel made up of agarose or of acryl amide.

Isolation of genes is the in vitro gene manipulation as it gives us the ability to bypass the multiplicity of mechanisms that restrict gene transfer between unrelated organisms and are far more accurate and subtle in nature. The broad outlines of this technique is: isolation of gene of interest, insertion of a gene into an appropriate vector, transfer of foreign DNA (gene) through the vector into an appropriate host organism to produce recombinant DNA and identification of recombinants.

### **DNA Isolation Methods**

Many different methods and technologies are available for the isolation of genomic DNA. In general, all methods involve disruption and lysis of the starting material followed by the removal of proteins and other contaminants and finally recovery of the DNA. Removal of proteins is typically achieved by digestion with proteinase K, followed by salting-out, organic extraction, or binding of the DNA to solid-phase support (either anion-exchange or silica technology). DNA is usually recovered by precipitation using ethanol or isopropanol. The choice of a method depends on many factors: the required quantity and molecular weight of the DNA, the purity required for downstream applications, and the time and expense.

The separation of DNA from cellular components can be divided into four stages:

1. Disruption
2. Lysis
3. Removal of proteins and contaminants
4. Recovery of DNA



### **12.6.2.1 Preparation of crude lysates**

An easy technique for isolation of genomic DNA is to incubate cell lysates at high temperatures (e.g., 90°C for 20 minutes), or to perform a proteinase K digestion, and then use the lysates directly in downstream applications. Considered “quick-and-dirty” techniques, these methods are only appropriate for a limited range of applications. The treated lysate usually contains enzyme-inhibiting contaminants, such as salts, and DNA is often not at optimal pH. Furthermore, incomplete inactivation of proteinase K can result in false negative results and high failure rates. It is not recommended to store DNA prepared using this method, as the high levels of +contamination often result in DNA degradation.

### **12.6.2.2 Salting-out methods**

Starting with a crude lysate, “salting-out” is another conventional technique where proteins and other contaminants are precipitated from the cell lysate using high concentrations of salt such as potassium acetate or ammonium acetate. The precipitates are removed by centrifugation, and the DNA is recovered by alcohol precipitation. Removal of proteins and other contaminants using this method may be inefficient, and RNase treatment, dialysis, and/or repeated alcohol precipitation are often necessary before the DNA can be used in downstream applications. DNA yield and purity are highly variable using this method.

### **12.6.2.3 Organic extraction methods**

Organic extraction is a conventional technique that uses organic solvents to extract contaminants from cell lysates. The cells are lysed using a detergent, and then mixed with phenol, chloroform, and isoamyl alcohol. The correct salt concentration and pH must be used during extraction to ensure that contaminants are separated into the organic phase and that DNA remains in the aqueous phase. DNA is usually recovered from the aqueous phase by alcohol precipitation. This is a time consuming and cumbersome technique. Furthermore, the procedure uses toxic compounds and may not give reproducible yields. DNA isolated using this method may contain residual phenol and/or chloroform, which can inhibit enzyme reactions in downstream applications, and therefore may not be sufficiently pure for sensitive downstream applications such as PCR. The process also generates toxic waste that must be disposed of with care and in accordance with hazardous waste



guidelines. In addition, this technique is almost impossible to automate, making it unsuitable for high-throughput applications.

#### **12.6.2.4 Cesium chloride density gradients**

Genomic DNA can be purified by centrifugation through a cesium chloride (CsCl) density gradient. Cells are lysed using a detergent, and the lysate is alcohol precipitated. Resuspended DNA is mixed with CsCl and ethidium bromide and centrifuged for several hours. The DNA band is collected from the centrifuge tube, extracted with isopropanol to remove the ethidium bromide, and then precipitated with ethanol to recover the DNA. This method allows the isolation of high-quality DNA, but is time consuming, labor intensive, and expensive (an ultracentrifuge is required), making it inappropriate for routine use. This method uses toxic chemicals and is also impossible to automate.

#### **12.6.2.5 Fragmentation by Mechanical Shearing:**

Random fragments of DNA can be generated by mechanical shearing. The desired fragments obtained by this method are without cohesive ends; therefore, the ligation (joining) with the vector can be facilitated with a process known as homopolymer tailing. For example, a tail of dC residues (deoxynucleotide triphosphate) can be added to 3-OH terminus of DNA of sheared fragment and a tail of dG residues vector. The fragments to be cloned can then be joined to the reactor by annealing the tails.

#### **12.6.2.6 Short- Gun method:**

There is a restriction enzyme which is specific for a six-base sequence of DNA. It is used to cut foreign DNA to get a piece of interest. One can obtain fragments of 3 to 4 genes by this method, if distribution of bases is random. The fragments obtained can be too small or too big if the no of cutting sites recognized by enzyme used are too frequent and too sparse in the distribution. It is also important that cutting sites fall on either end of gene of interest and not in between. When the same enzyme is used to cut the vector DNA, cohesive ends are created, in most cases depending on the nature of enzyme, the joining of vector and the isolated DNA is possible.

#### **12.6.2.7 cDNA method:**

If animal gene is to be expressed in a bacterium or yeast, a suitable method is to isolate the messenger RNA (mRNA), first, concerned with the specific protein production. It is often impossible to express animal gene directly in bacteria because of the introns within the gene. The protein encoding parts of the genes are exons. Mature mRNA molecules in animal cells do not contain sequences

complementary to introns as they are removed by processing. Introns are the sequences in DNAs which are in fact transcribed into mRNAs but are subsequently split out are therefore form no permanent consequents of the mRNAs (only reverse transcriptase and DNA polymerase. Thus cDNA produced for a particular product can be then joined to the appropriate vector for cloning by homopolymer tailing as described above or proper linkers.

---

## 12.7 Gel Electrophoresis

---

Gel matrices should have adjustable and regular pore size, should be chemically inert and should not exhibit electroosmosis. *Electroosmosis* is the phenomenon of migration of water towards an electrode as a result of the supporting medium and/or the surfaces of the separation equipment, *e.g.*, of capillaries, also carrying charge. The gel can be as vertical rods, as plates or horizontal slabs. The following types of gels are commonly used.

**Agarose Gels:** These gels have large pores, and are used for analysis of molecules of over 10nm diameter. Agarose is a polysaccharide obtained from red seaweed. When agaropectin is removed, agarose gels with melting points from 35<sup>0</sup>C to 95<sup>0</sup> C and varying degrees of electroosmosis are obtained. Agarose dissolves in hot water. When this solution is cooled, double helices form and become arranged laterally the produce thick filaments; these filaments become cross-linked to form the gel. Pore size depends on agarose concentration (w/v): in general, a 1% (w/v) gel will have a pore size of 150 nm, while a 0.16 % gel has a pore size of 500nm.

Gels having 0.7 to 1% agarose have a larger pore size. Such horizontal agarose gels are used for the separation of high molecular weight proteins, *i.e.*, serum proteins, and enzymes, *e.g.*, isoenzymes of diagnostic importance, and of large (few to several kb) fragments of DNA. Proteins separated in agarose gel can be subjected to immunofixation, immunoprinting and immunoblotting. Agarose gels are also used for immunoelectrophoresis and affinity electrophoresis.

Agarose gels above 1% concentration are cloudy and exhibit high electro-osmotic flow. These gels are, therefore used for the separation of very high molecular weight proteins or protein aggregates. However, they are the standard medium for separation, identification RFL- analysis, and purification of DNA and RNA fragments; for these applications, horizontal submarine agarose gels are used to prevent the gel from drying out.

**Polyacrylamide Gels:** these gels are obtained by copolymerization of acrylamide ( $\text{CH}_2=\text{CH}-\text{CONH}_2$ ) monomers with a cross-linking reagent (usually, N,N'-methylene bisacrylamide, *bisacrylamide* in short)

Polyacrylamide gels are transparent, chemically inert and particularly, mechanically stable, and they exhibit very little electroosmosis. The temperature during polymerization should be maintained above  $20^{\circ}\text{C}$  in order to prevent incomplete polymerization. In addition, polymerization should take place under an inert atmosphere since oxygen can act as a free radical trap. Oxygen absorption is minimized by casting the gels in vertical chambers, *e.g.*, molds formed by two glass plates sealed together around the edges in the case of flats gels. *The monomers are toxic; therefore that should be handled with the utmost care.*

Horizontal polyacrylamide gels polymerized on ultra-thin films are used to separate low molecular weight compounds, *e.g.*, dyes with molecular weights of 500 Daltons. Polyacrylamide gels are also used for analysis of nucleic acids, *e.g.*, DNA sequencing, for viroid tests (detects presence and also the types of viroids) and to detect mutations, as well as for analysis of proteins. These applications are briefly described below.

The pore size of the gel depends on the following two factors: (1) the total concentration ( $T$ ) of the acryl amide and bisacrylamide monomers in the solution, and (2) the proportion (in per cent) of bisacrylamide ( $C$ ) in the total monomer concentration. The values of  $T$  and  $C$  are given by the following formulae.

$$T = \frac{\text{Mass (in g) of acryl amide} + \text{mass of bisacrylamide} \times 100}{\text{Volume of the solution (ml)}}$$

$$C = \frac{\text{Mass of bisacrylamide} \times 100}{\text{Mass of acrylamide} + \text{mass of bisacrylamide}}$$

When  $T$  is increased, while  $C$  is kept constant, the pore size of gel decreases. But when  $C$  is increased, while  $T$  remains constant, the pore size decreases till  $C$  equals 4%; beyond this value of  $C$ , the pore size again increases. *The pore size of polyacrylamide gels, therefore, can be exactly and predictably controlled by controlling the values of  $T$  and  $C$ .* It may be pointed out that gels with  $C$ , 5% are brittle and relatively hydrophobic; such gels are used only in special cases.

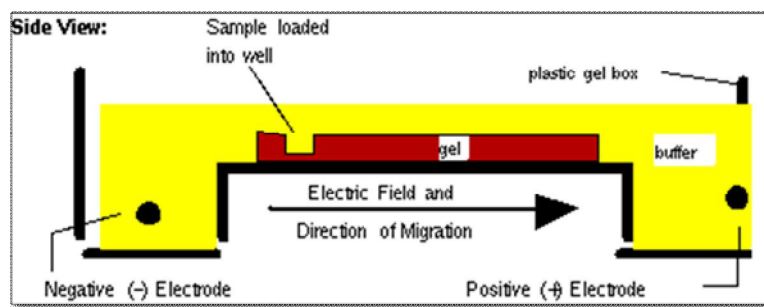

**Figure 4 Principle of Electrophoresis**

## 12.8 Polymerase Chain Reaction

The in-vitro amplification of DNA by repeated cycles of strand DNA separation and polymerization by DNA polymerase activity is known as Polymerase chain reaction. The PCR was invented by Kary Mullis in 1985. Mullis received the Nobel Prize and the Japan Prize for developing PCR in 1993. This technique is used for gene amplification.

The establishment of the PCR has revolutionized research in molecular biology and is increasingly applied in most molecular biology laboratory, in medical diagnostics and other fields, such as forensic sciences, archeology, anthropology and molecular systematic. PCR is an elegant method to produce 10 and more copies of DNA from a mixture of total DNA within a couple of hours.

In the past, genes or pieces of DNA were isolated, purified and cloned before they were further analyzed by electrophoresis, hybridization and DNA sequencing. At present, a single PCR experiment starting with total DNA mixtures will provide enough material for further analysis and processing, which include electrophoresis and staining with ethidium bromide, radiolabelling or the incorporation of fluorescent dyes for sequencing reactions.

### 12.8.1 Methodology of PCR

One cycle – three temperature shifts:

- 1.) Denaturation at 94- 96°C
- 2.) Primer annealing at 45-46 °C (depending on the primer)
- 3.) Primer extension (usually) at 72°C

In the first step, double stranded DNA is separated into single stranded DNA by heating it to 94°C. Upon cooling to 52°C single stranded DNA tends to anneal with the complementary DNA strand. If PCR primers are present in excess

these primers will anneal to single stranded-DNA at position which are complementary to their nucleotide sequence. The reaction mixture is heated 72°C which is the optimum condition for Taq DNA-polymerase.

Taq polymerase replicates the template using PCR primer as a starter. Continuing with the denaturation step the cycle is repeated for usually thirty times resulting 10 copies of original DNA which was present at the start. Amplification is exponential at first but after >20 cycles the number of product molecules exceeds the number of enzyme molecules and amplification slows down.

### **12.8.2 Characterization of PCR-Products:**

A quick and simple method to characterize PCR products is their electrophoresis on agarose gels and staining with ethidium bromide. PCR products can be cleaved by restriction enzymes which may be useful to verify whether the correct product was obtained. This requires a prior knowledge of the respective cleavage sites in the target genes. Alternatively, PCR products may be identified by a Southern Analysis.

### **12.8.3 Applications of PCR**

PCR has many exciting and varied applications. Some of these are briefly outlined below.

1. PCR can be used to amplify a specific gene present in different individuals of a species and even in different somatic cells or gametes, say, human sperms. These copies can be used for cloning. Alternatively, they can be sequenced to obtain information on the mutational changes in the genes of different individuals, cells or gametes. Such data can be used in disease diagnosis, population genetics, estimation of recombination frequencies etc.
2. PCR can be used to study DNA polymorphism in the genome using known sequences as primers. Synthetic nucleotides of any sequence can be used as random primers to amplify polymorphic DNA's having sequences specific to the primers used. Such an application of PCR generates *random amplified polymorphic DNA* (RAPD, pronounced as 'rapid'), which is detected as bands after electrophoresis. RAPD bands of different strains or species can be compared. They can be used to construct RAPD maps, similar to RFLP maps.

3. PCR can be used to detect the presence of a gene transferred into an organism (*transgene*) by using the end sequences of the transgene for amplification of DNA from the putative transgenic organism. Amplification will occur only when the transgene is present in the organism; the amplified DNA is detected as a band on the electrophoretic gel.
4. Microdissected segments of chromosomes, i.e., of salivary gland chromosomes of *Drosophila*, can be used for PCR amplification to determine the physical location of specific genes in chromosomes.
5. PCR can be used to determine the sex of embryos. Thus the sex of in vitro fertilized cattle embryos could be determined using Y chromosome-specific primers before their implantation in the uterus.

#### **12.8.4 Limitations of PCR**

1. Only relatively short sequences can be amplified reliably. Anything more than 10,000 base pairs are unlikely to be amplified.
2. You need to know the right primer sequences to use, at both ends of the sequence you want to amplify. If two related genes have the same end sequences, you might amplify the wrong gene.

---

### **12.9 DNA Sequencing**

---

Determination of the order of nucleotides of a DNA is called DNA sequencing. It is very important for the genetic analysis of DNAs. The nucleotide sequence data is very useful to understand traits which are coded by DNA. It is the primitive step to manipulate DNA in desired way.

Refined techniques allow separation of DNA fragments differing for single base pairs for a total length of up to 500 bp. The sensitivity for 0.5 mm polyacrylamide gels is much higher than that for agarose gels. This is because silver staining is more effective in polyacrylamide gels than in agarose gels; silver staining can detect 50 pg of nucleic acid per band, while the limit for ethidium bromide is 1 ng of DNA. Gels polymerized on films are easy to handle when they have large pores, e.g., gels with *T* of 2% and *C* of 9%; such gels allow separation of relatively long DNA chains of ~2,300bp.

The products of DNA sequencing reactions are subjected to vertical electrophoresis under conditions that completely denature the DNA molecules;

this ensures that the chain-terminated polynucleotides (only these polynucleotide's will yield the base sequence) are completely separated from the template DNA and that they do not form secondary structures due to internal pairing. Denaturation is achieved by running the gel at 50<sup>0</sup> C in the presence of urea. Irregular heat distribution usually results in a higher temperature in the middle of the gel so that DNA fragments migrate faster in the middle than they do at edges of the gel. As a consequence, the DNA bands at the end of the gel are progressively more advanced as one move from the two edges to the middle of the gel; this is commonly known as the '*smiling*' effect. Smiling effect can be minimized by pre warming the gels with thermo plates independent of the heating due to the electric field. In manual sequencing, radiolabelling is used, and the sequence is read manually following autoradiography. But in automated DNA sequencing, fluorescent labels are used and the base sequence is obtaining through a computer programme.

---

## **12.10 Insertion of Recombinant DNA into host cell**

---

The most common ways to insert recombinant DNA into cells reflect the observations of how recombinant DNA forms in nature.

In bacteria, scientists had observed the passage of genetic material between organisms in three ways:

- Conjugation - transfer of information using sex pili
- Transduction - transfer of information by bacteriophages
- Transformation - uptake of naked DNA from outside the cell

### **12.10.1 Bacterial Transformation**

The simplest way bacteria can take up foreign DNA is through transformation, a technique used very frequently in molecular biology labs. In this technique bacteria take up purified DNA through chemical and heat shock. Bacterial cell walls do not normally allow DNA in, and must be made "competent" to take up DNA. Treating bacteria with calcium chloride makes them take up water and DNA, and a subsequent heat shock activates genes that help bacteria recover from the calcium chloride treatment.

### **12.10.2 Bacterial Conjugation**

In the process of bacterial conjugation, bacteria transfer native plasmids -- small circular pieces of DNA -- to other bacteria. The plasmid contains a special sequence known as the F-factor, and one bacterium forms a threadlike

structure called a pilus to transfer a copy of its F-factor-containing plasmid to another bacterium. The plasmid containing the F-factor can have other genes besides the F-factor, and in this way various genes can be inserted from one bacterium to another. This technique can be harnessed in the molecular biology laboratory to insert a DNA sequence of interest into bacteria.

### **12.10.3 Bacterial Transduction**

Like animal cells, bacteria have viruses that can infect them. Bacterial viruses are called bacteriophages. The life cycle of a bacteriophage involves the insertion of the bacteriophage's DNA into the host cell DNA, followed by removal of the bacteriophage DNA when the phage is ready to reproduce itself. Bacteriophage insertion is known as transduction. Generalized transduction is used to insert foreign DNA into bacterial cells in laboratories. The process takes advantage of bacteriophage reproduction, in which they sometimes package bacterial DNA into their phage particles that is later transferred to a separate bacterium.

### **12.10.4 Mammalian Cell Transfection**

Mammalian cells can be made to take up foreign DNA through two methods - both of which are called transfection. Chemical transfection involves treating cells with a chemical like calcium phosphate, which allows them to take up DNA by a mechanism that isn't understood. Another method involves using viruses to insert foreign DNA, similar to bacterial transduction. This method is called virus-mediated transfection, or simply transduction. At the time of publication, it is of limited use in research because viruses have a limited capacity for carrying DNA.

---

## **12.11 Summary**

---

A recombinant DNA molecule is produced by joining together two or more DNA segments usually originating from different organisms. This is achieved by using specific enzymes for cutting the DNA into suitable fragments and then for joining together the appropriate fragments. This feature to produce recombinant DNA molecules has given man the power and opportunity to create novel gene combination to suit specific needs.

---

## **12.12 Glossary**

---

- **Adaptor-** A short double stranded oligonucleotide which has one blunt end and a cohesive end being used in ligation



- **Agarose gel**- A matrix formed of agar for electrophoresis
- **Amplification**- A rapid production of more copies of DNA
- **Blotting**- Making a blot on a membrane filter or pouring a solution in the wells of an electrophoresis gel
- **c-DNA**- A double stranded DNA complementary to a m-RNA synthesized by reverse transcription
- **Chimera**- An animal which is an assemblage of cells of different species
- **Cosmid**- A *cos* site containing plasmid being used to transfer foreign DNA
- **DNA ligase**- An enzyme which make phosphodiester bond in between nucleotide
- **Gene cloning**- Multiplication of exact copy of DNA by introducing rDNA into a host cell
- **Genome**- The entire genetic material of an organism
- **Genomic library**- A collection of DNA clones that represent the entire genomic DNA of an organism
- **Plasmid**- A circular double stranded extra chromosomal DNA which has its own origin of replication presents in a bacterial cell.
- **Polyacrylamide gel**- A gel matrix used for separation of nucleic acid.

---

## 12.13 Self Learning Exercise

---

### Section -A (Very Short Answer Type)

1. Name the different types roles that RDT play in genetics?
2. Who invented the technique PCR?
3. Define cosmids.
4. Expand RFLP and RAPD?
5. Denaturation of DNA occurs on temperature \_\_\_\_\_.
6. DNA ligase creates a \_\_\_\_\_ bond between two DNA ends
7. Agarose Gels which are used for analysis of molecules have \_\_\_\_\_ diameter.
8. What are the four stages in which separation of DNA on the basis of

cellular components is divided?

9. Define copy number.
10. Define YAC.

#### **Section -B (Short Answer Type)**

1. Write a note on vectors.
2. Briefly explain the methodology of PCR?
3. Write a brief note on isolating the gene for interest.
4. Define DNA sequencing?
5. Write down the major applications and limitations of PCR.

#### **Section -C (Long Answer Type)**

1. What is Recombinant DNA Technology? What are the steps involved in RDT?
2. Write an explanatory note on PCR amplification technique.
3. Discuss the importance of the process of insertion of recombinant DNA into host cell
4. What are the different methods for the isolation of genomic DNA?
5. Give a detailed account of DNA sequencing.
6. Give a detailed account of various vector.

---

## **12.9 References**

---

- Brown, T. A. (2001). *Gene cloning an introduction, 4th edition*. Blackwell Science, Oxford, UK
- Purohit. S.S. (2005). *Biotechnology: Fundamentals and Applications*. Agrobios, India
- Singh. B.D. (2010). *Biotechnology*. Kalyani Publishers. India
- Watson, J. D.(1992). *Recombinant DNA, 2nd edition*. Scientific American Books,
- USA.

- Primrose, S. B., Twyman, R., Old, R. W. (2001). *Principles of gene manipulation, 6th*
- *edition*. Blackwell Science, Oxford, UK.
- Kumaresan, V 2013. Biotechnology Sixth edition, *Saras publication, India*

# Unit - 13

---

## Bioreactors and downstream processing

---

### Structure of the Unit

- 13.0 Objective
- 13.1 Introduction
- 13.2 Design of Fermenter
- 13.3 Classification of bioreactors
- 13.4 Body construction of bioreactor
  - 13.4.1 Construction materials of bioreactors
  - 13.4.2 Vessel shape
  - 13.4.3 Baffles
  - 13.4.4 Aeration System (SPARGER)
  - 13.4.5 Steam Traps
- 13.5 Types of Bioreactors
  - 13.5.1 Stirred Tank Fermenter
  - 13.5.2 Airlift fermenter
  - 13.5.3 Fluidized bed bioreactors
  - 13.5.4 Packed bed bioreactor
  - 13.5.5 Bubble column fermenter
- 13.6 Downstream Processing
- 13.7 Summary
- 13.8 Glossary
- 13.9 Self-Learning Exercise
- 13.10 References

---

### 13.0 Objective

---

After going through this unit you will be able to understand:

- What is downstream processing?
- How fermenters are constructed?

- What is the role bioreactors in fermentation technology?
- How products are recovered from bioreactors?

---

## 13.1 Introduction

---

Biotechnology is the culmination of more than 8000 years of human experience using living organisms and the process of fermentation to make products such as bread, cheese, beer and wine. Today biotechnology is applied to manufacturing processes used in health care, food and agriculture. A widely accepted definition of Biotechnology is "Application of scientific and engineering principles to processing of materials by biological agents to provide goods and service". Some other definitions replace rather ambiguous word 'biological agents' with more specific words such as microorganisms, cells, plant and animal cells and enzymes. The entire process can be divided in three stages.

Stage I : Upstream processing which involves preparation of liquid medium, separation of particulate and inhibitory chemicals from the medium, sterilization, air purification etc.

Stage II: Fermentation which involves the conversion of substrates to desired product with the help of biological agents such as microorganisms.

Stage III: Downstream processing which involves separation of cells from the fermentation broth, purification and concentration of desired product and waste disposal or recycle.

A fermentation process requires a fermenter or bioreactor for successful production because it provides the following facilities for the process such as contamination free environment, specific temperature maintenance, maintenance of agitation and aeration, pH control, monitoring Dissolved Oxygen (DO), ports for nutrient and reagent feeding, ports for inoculation and sampling, fittings and geometry for scale up, minimize liquid loss and growth facility for wide range of organisms. The definition of bioreactor is "Bioreactor is a vessel in which a chemical process is carried out which involves organisms (mainly microbes-viruses or bacteria, fungi and yeasts) or biochemically active substances (enzymes, e.g.) derived from such organisms." This process can either be aerobic or anaerobic. Traditionally designated as "Fermenters"

The environmental conditions of a bioreactor like gas (oxygen, nitrogen, carbon dioxide) and liquid flow rates, temperature, pH, concentration of substrate and products, cells number and their composition (proteins and nucleic acids), dissolved oxygen levels, and agitation speed (or circulation rate) need to be closely and continuously monitored and controlled. In many cases, strictly aseptic conditions have to be maintained. In an aerobic process, optimal oxygen transfer is perhaps the most difficult task to accomplish because there are limits to the speed of agitation, for maintaining high power consumption and to the damage to organisms caused by excessive tip speed.

The general requirements of the bioreactor are as follows:

- (a) The design and construction of bioreactors must be such that sterile conditions are maintained. Furthermore, monoseptic conditions should be maintained during the fermentation and ensure containment.
- (b) Optimal mixing with low, uniform shear must be achieved by proper designing of agitator and aerator
- (c) Adequate mass transfer (oxygen) must be achieved by monitoring the speed of agitator.
- (d) Clearly defined flow conditions must be maintained by proper opening valves and monitoring devices.
- (e) Feeding of substrate must be maintained with prevention of under or overdosing by proper feed ports.
- (f) Suspension of solids and gentle heat transfer.
- (h) Compliance with design requirements such as: ability to be sterilized; simple construction; simple measuring, control, regulating techniques; scaleup; flexibility; long term stability; compatibility with up- downstream processes; antifoaming measures.

---

## **13.2 Design of Fermenter**

---

A bioreactor is a specially designed vessel which is built to support the growth of high concentration of microorganisms. It must be so designed that it is able to provide the optimum environments or conditions that will allow supporting the growth of the microorganisms. Bioreactors are commonly cylindrical vessels with hemispherical top and/or bottom, ranging in size from some liter to cube meters, and are often made of

stainless steel and glass. The difference between a bioreactor and a typical composting system is that more parameters of the composting process can be measured and controlled in bioreactors. The sizes of the bioreactor can vary over several orders of magnitudes. The microbial cell (few mm<sup>3</sup> ), shake flask (100-1000 ml), laboratory fermenter (1 – 50 L), pilot scale (0.3 – 10m<sup>3</sup> ) to plant scale (2 – 500 m<sup>3</sup> ) are all examples of bioreactors. The design and mode of operation of a fermenter mainly depends on the production organism, the optimal operating condition required for target product formation, product value and scale of production. The design also takes into consideration the capital investment and running cost.

There are four basic components of a bioreactor including:

1. Drive motor, heaters, pump, etc.,
2. Vessels and accessories
3. Peripheral equipment (reagent bottles)
4. Instrumentation and sensors

Before designing a bioreactor following points should be considered:

1. The vessel should be robust and strong enough to withstand the various treatments required such as exposure to high heat, pressure and strong chemicals and washings and cleanings.
2. The vessel should be able to be sterilized and to maintain stringent aseptic conditions over long periods of the actual fermentation process.
3. The vessel should be equipped with stirrers or mixers to ensure mass transfer processes occur efficiently.
4. It should have sensors to monitor and control the fermentation process.
5. It should be provided with inoculation point for aseptic transfer in inoculum.
6. Sampling valve for withdrawing a sample for different tests.
7. Baffles should be provided in case of stirred fermenter to prevent vortex formation.
8. It should be provided with facility for intermittent addition of an antifoam agent.

9. In case of aerobic submerged fermentation, the tank should be equipped with the aerating device.
10. Provision for controlling temperature and pH of fermentation medium.
11. Man hole should be provided at the top for access inside the fermenter for different purposes.

---

### **13.3 Classification of bioreactors**

---

Bioreactors can be classified on the bases of:

1. Mode of operation: A bioreactor may be classified as batch, fed batch or continuous reactor on the bases of mode of operation.
2. Mode of flow of fluids: A bioreactor may be classified as CSTR bioreactor (continuous flow stirred reactor-the content of the bioreactor is ideally mixed), bioreactor with piston flow and bioreactors with non-ideal flow of fluids (cascade of ideal mixtures, dispersed flow of fluids) on the bases of mode of flow of fluids. The quality of flow of fluids significantly influences the rate of grow of cells and the degree of conversion of substrate and consequently, the yield and selectivity of the products.
3. Number of phases treated into the bioreactor: we can distinguish bioreactors as homogeneous bioreactors (e.g. one phase tubular bioreactor with enzyme diluted in the liquid substrate) and heterogeneous bioreactors (e.g. two phase solid-liquid bioreactor like the column type bioreactor with immobilized enzyme and liquid substrate) and/or three phase bioreactors with submersed culture: gas (air bubbles)-liquid (substrate)-solids (cells).

---

### **13.4 Body construction of bioreactor**

---

#### **13.4.1 Construction materials of bioreactors:**

Construction materials of bioreactors differ with small scale, pilot and large scale utelization. In small scale for bioreactor construction glass or stainless steel may be used. For pilot and large scale process, stainless steel (>4% chromium), mild steel (coated with glass or epoxy material), wood, plastic or concrete may be used as vessel construction material. Any vessel used should not have any corners and smooth surface is essential. The construction material must be non toxic and corrosion proof. The corrosion resistance of stainless steel is thought to depend on the existence of a thin hydrous oxide film on the surface of metal.



### 13.4.2 Vessel shape: -

Typical tanks are vertical cylinders with specialized top plates and bottom plates. In some cases, vessel design eliminates the need for a stirrer system especially in air lift fermenter. The top plates are of an elliptical or spherical dish shape. The top plates can be either removable or welded. A removable top plate provides best accessibility, but adds to cost and complexity. Various ports and standard nozzles are provided on the stainless plate for actuators and probes. These include pH, thermocouple, and dissolved oxygen probes ports, defaming, acid and base ports, inoculum port, pipe for sparging process air, agitator shaft and spare ports.

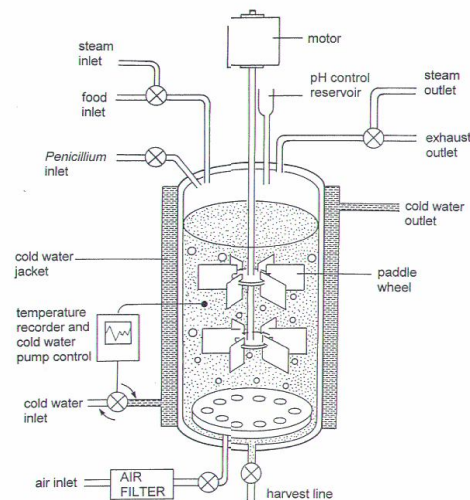

Tank bottom plates are also customized for specific applications. Almost most of the large vessels have a dish bottom, while the smaller vessels are often conical in shape or may have a smaller, sump type chamber located at the base of the main tank.

Sealing between top plate and vessel is an important criteria to maintain airtight condition, aseptic and containment. Sealing have to be done between three types of surfaces viz. between glass-glass, glass- metal and metal-metal. There are three types of sealing. They are gasket, lip seal and 'O' ring. This sealing ensures tight joint in spite of expansion of vessel material during fermentation. The materials used for sealing may be fabric-nitril or butyl rubbers. The seals should be changed after finite time. There are two way of sealing in O ring type simple sealing and double sealing with steam between two seals.

### **13.4.3 Baffles:**

Baffles are metal strips that prevent vortex formation around the walls of the vessel. These metal strips are attached radially to the wall for every  $1/10^{\text{th}}$  of vessel diameter. Usually 4 baffles are present. There should be enough gap between wall and baffle so that scouring action around vessel is facilitated. This movement minimizes microbial growth on baffles and fermentation walls. If needed cooling coils may be attached to baffles.

The agitator (impeller)

Agitation provides uniform suspension of cells in homogeneous nutrient medium and agitation provides bulk fluid and gas phase mixing. It is achieved by: bulk fluid and gas-phase mixing, Air dispersion, Oxygen transfer, Heat transfer, Suspension of solid particles and maintain a uniform environment throughout the vessel contents. Enhancement of mass transfer between dispersed phases. There are four classes of impeller, namely Disc turbine, Vaned disc, Open turbine of variable pitch and Marine impeller.

### **13.4.4 Aeration System (SPARGER):**

Sparger is a device for introducing air into fermenter. Aeration provides sufficient oxygen for organism in the fermenter. Fine bubble aerators must be used. Large bubbles will have less surface area than smaller bubbles which will facilitate oxygen transfer to a greater extent. Air supply to sparger should be supplied through filter. There are three types of sparger viz. porous sparger, orifice sparger and nozzle sparger.

Valves and Steam Traps:

Four types of valves are there on a bioreactor:

1. Addition valves: There are four types of addition valves viz.  
(a) Simple ON and OFF, (b) For coarse control, (c) Accurate adjustment and (d) Safety valve-flow in one direction.
2. Check valves: Valves used to prevent accidental reversal flow of liquid or gas due to break down. There are three types – swing check, lift check, combined stop and check.
3. Pressure control valves: These types of valves are used for two purposes. (a) Pressure reduction (b) Pressure retaining.
4. Safety valve: There are types of safety valve by which the increase in pressure is released. They are, (a) A spindle lifted from its seating against the pressure – releases pressure (b)

Bursting / rupturing of discs to release pressure In case of releasing the gas, the escaping gas must be treated before release.

**13.4.5 Steam Traps:** Steam trap is important to remove any steam condensate. There are two components *viz.* valve and seat assembly and open / close device. The operation of the component is based on:

**(i) Density of fluid :** A float (ball / bucket) float in water, sink in steam. When it floats it closes and when it sinks it opens the valve.

**ii) Temperature of fluid :** It has water / alcohol mixture which senses the change in temperature. This mixture expands in hot steam and closes the valve. When it contracts in cool water opens the valve.

**iii) Kinetic effect of fluid in motion :** If a low density steam is flowing it will be high velocity. Like wise high density will flow with low velocity. The conversion of pressure energy into kinetic energy control the opening and closing.

---

## 13.5 Types of Bioreactors

---

The main function of a fermenter is to provide a controlled environment for the growth of

microorganisms or animal cells, to obtain a desired product. Few of the bioreactor types are

discussed below:

### 13.5.1 Stirred Tank Fermenter

Stirred tank reactor's have the following functions: homogenization, suspension of solids, dispersion of gas-liquid mixtures, aeration of liquid and heat exchange. The Stirred tank reactor is provided with a baffle and a rotating stirrer is attached either at the top or at the bottom of the bioreactor. The typical decision variables are: type, size, location and the number of impellers; sparger size and location. These determine the hydrodynamic pattern in the reactor, which in turn influence mixing times, mass and heat transfer coefficients, shear rates etc. The conventional fermentation is carried out in a batch mode. Since stirred tank reactors are commonly used for batch processes with slight modifications, these reactors are simple in design and easier to operate.

### 13.5.2 Airlift fermenter

Airlift fermenter (ALF) is generally classified as pneumatic reactors without any mechanical stirring arrangements for mixing. The turbulence caused by the fluid flow ensures adequate mixing of the liquid. The draft tube is provided in the central section of the reactor. The introduction of the fluid (air/liquid) causes upward motion and results in circulatory flow in the entire reactor. The air/liquid velocities will be low and hence the energy consumption is also low. ALFs can be used for both free and immobilized cells. The advantages of Airlift reactors are the elimination of attrition effects generally encountered in mechanical agitated reactors. It is ideally suited for aerobic cultures since oxygen mass transfer coefficients are quite high in comparison to stirred tank reactors. This is ideal for SCP production from methanol as carbon substrate. This is used mainly to avoid excess heat produced during mechanical agitation.

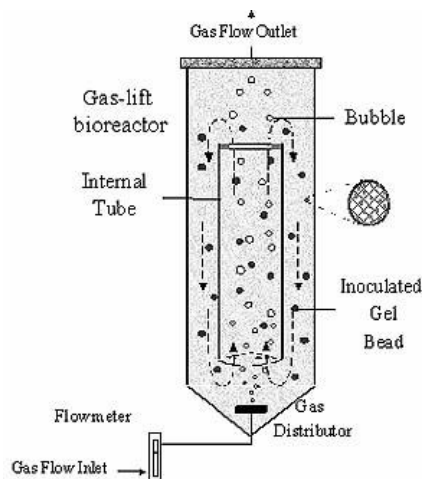

Fig.3 Airlift fermenter

### 13.5.3 Fluidized bed bioreactors:

Fluidized bed bioreactors (FBB) have received increased attention in the recent years due to their advantages over other types of reactors. Most of the FBBs developed for biological systems involving cells as biocatalysts are three phase systems (solid, liquid & gas). The fundamentals of three phase fluidization phenomena have been comprehensively covered in chemical engineering literature. The FBBs are generally operated in co-current upflow with liquid as continuous phase and other more unusual configurations like the inverse three phase fluidized bed or gas solid fluidized bed are not of much importance. Usually fluidization is obtained either by external liquid re-circulation or by gas fed to the reactor.

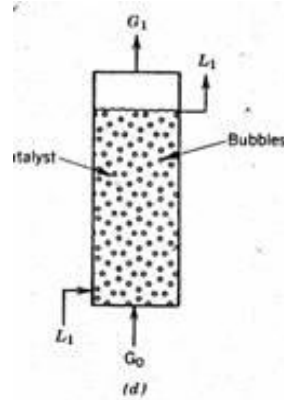

Fig.4 Fluidized bed bioreactors

### 13.5.4 Packed bed bioreactor:

Packed bed or fixed bed bioreactors are commonly used with attached biofilms especially in wastewater engineering. The use of packed bed reactors gained importance after the potential of whole cell immobilization technique has been demonstrated. The immobilized biocatalyst is packed in the column and fed with nutrients either from top or from bottom. One of the disadvantages of packed beds is the changed flow characteristic due to alterations in the bed porosity during operation. While working with soft gels like alginates, carragenan etc the bed compaction which generally occurs during fermentation results in high pressure drop across the bed. In many cases the bed compaction was so severe that the gel integrity was severely hampered. In addition channeling may occur due to turbulence in the bed. The packed bed reactors are widely used with immobilized cells. Several modifications such as tapered beds to reduce the pressure drop across the length of the reactor, inclined bed, horizontal bed, rotary horizontal reactors have been tried with limited success.

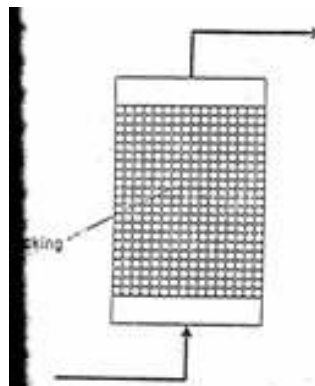
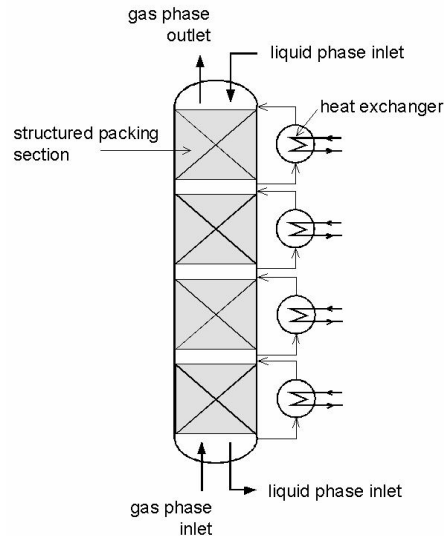

Fig.5 Packed bed bioreactor

### 13.5.5 Bubble column fermenter:

Bubble column fermenter is a simplest type of tower fermenter consisting of a tube which is air sparged at the base. It is an elongated non-mechanically stirred fermenter with an aspect ratio of 6:1. This type of fermenter was used for citric acid production.



**Fig.6 Bubble column fermenter**

---

## 13.6 Downstream Processing

---

Downstream processing refers to the recovery and purification of biosynthetic products, particularly pharmaceuticals, from natural sources such as animal or plant tissue or fermentation broth and the proper treatment and disposal of waste. It is an essential step in the manufacture of pharmaceuticals such as antibiotics, hormones, antibodies and vaccines; antibodies and enzymes used in diagnostics; industrial enzymes; and natural fragrance and flavor compounds. Downstream processing is usually considered a specialized field in biochemical engineering. Downstream processing implies manufacture of a purified product fit for a specific use, generally in marketable quantities.

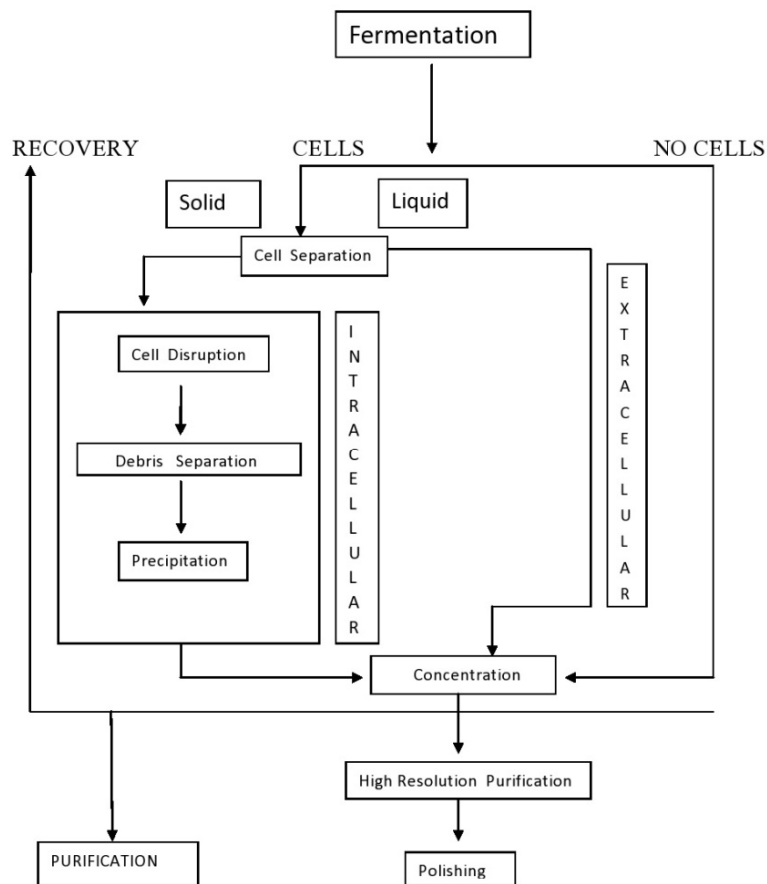

Stages in downstream processing:

downstream processing operations divides them into four groups which are applied in order to bring a product from its natural state as a component of a tissue, cell or fermentation broth through progressive improvements in purity and concentration.

1. Removal of insolubles is the first step and involves the capture of the product as a solute in a particulate-free liquid, for example the separation of cells, cell debris or other particulate matter from fermentation broth containing an antibiotic. Typical operations to achieve this are filtration, centrifugation, sedimentation, precipitation, flocculation, electro-precipitation, and gravity settling. Additional operations such as grinding, homogenization, or leaching, required to

recover products from solid sources such as plant and animal tissues, are usually included in this group.

2. Product isolation is the removal of those components whose properties vary markedly from that of the desired product. For most products, water is the chief impurity and isolation steps are designed to remove most of it, reducing the volume of material to be handled and concentrating the product. Solvent extraction, adsorption, ultrafiltration, and precipitation are some of the unit operations involved.
3. Product purification is done to separate those contaminants that resemble the product very closely in physical and chemical properties. Consequently steps in this stage are expensive to carry out and require sensitive and sophisticated equipment. This stage contributes a significant fraction of the entire downstream processing expenditure. Examples of operations include affinity, size exclusion, reversed phase chromatography, crystallization and fractional precipitation.
4. Product polishing describes the final processing steps which end with packaging of the product in a form that is stable, easily transportable and convenient. Crystallization, desiccation, lyophilization and spray drying are typical unit operations. Depending on the product and its intended use, polishing may also include operations to sterilize the product and remove or deactivate trace contaminants which might compromise product safety. Such operations might include the removal of viruses or depyrogenation.
5. A few product recovery methods may be considered to combine two or more stages. For example, expanded bed adsorption (Vennapusa et al. 2008) accomplishes removal of insolubles and product isolation in a single step. Affinity chromatography often isolates and purifies in a single step.

---

## **13.7 Summary**

---

In the present chapter various designs of fermenters are discussed which can be used for various types of fermentation processes. Basic components of fermenter are explained in detail and monitoring and controlling devices to maintain a controlled condition in a fermenter have also been discussed. The fermentation processes that are used by various biotechnology based industries had lead to increasing quantities of various products. Basic steps for downstream processing are removal of insolubles , typical operations to



achieve this are filtration, centrifugation, sedimentation, precipitation, flocculation, electro-precipitation, and gravity settling. Product isolation is the next step which may be achieved by solvent extraction, adsorption, ultrafiltration, and precipitation are some of the unit operations involved. Then product purification is done to separate contaminants, after this product polishing is done.

---

### 13.8 Glossary

---

- **Upstream processing:** Involves preparation of liquid medium, separation of particulate and inhibitory chemicals from the medium, sterilization, air purification etc.
- **Fermentation :** Involves the conversion of substrates to desired product with the help of biological agents such as microorganisms.
- **Downstream processing:** Involves separation of cells from the fermentation broth, purification and concentration of desired product and waste disposal or recycle.

---

### 13.9 Self-Learning Exercise

---

#### Section -A (Very Short Answer Type)

1. .... involves separation of cells from the fermentation broth, purification and concentration of desired product and waste disposal or recycle.
2. .... involves the conversion of substrates to desired product with the help of biological agents such as microorganisms.
3. .... involves preparation of liquid medium, separation of particulate and inhibitory chemicals from the medium, sterilization, air purification etc.
4. Sparger is a device for ..... into fermenter.
5. The design and construction of bioreactors must be such that .....are maintained.

#### Section -B (Short Answer Type)

1. Define bioreactor.
2. What is downstream processing?
3. What is upstream processing?

4. Which conditions should be maintained in a bioreactor to recover a product?

**Section -C (Long Answer Type)**

1. Explain basic construction of a bioreactor.
2. Write in detail about various types of bioreactors
3. Explain in detail about downstream processing
4. What care should be taken before constructing a bioreactor?

**Answer Key of Section-A**

1. Downstream processing
2. Fermenter
3. Upstream Processing
4. Introduce air
5. sterile conditions

---

**13.10 References**

---

- Microbial Biotechnology-Fundamentals of applied Microbiology by A.N. Glazer and H. Nikaido. W.H Freeman and company
- Principles of Fermentation Technology, P.F. Stanbury & A. Whitaker, Pergamon
- Biotechnology Text book of Industrial Microbiology by W. Creuger and A Creuger

# Unit – 14

---

## Biotechnology in Medicine

---

### Structure of the Unit

- 14.0 Objectives
- 14.1 Introduction
- 14.2 Humulin and its production
  - 14.2.1 Historical perspectives
  - 14.2.2 Production of humulin
  - 14.2.3 Types of humulin
  - 14.2.4 Advantages of humulin
  - 14.2.5 Disadvantages of humulin
- 14.3 Gene Therapy
  - 14.3.1 Types of gene therapy
  - 14.3.2 Procedure of gene therapy
  - 14.3.3 Technological hurdles and risks involved
  - 14.3.4 Ethical issues involved
- 14.4 Molecular diagnostics
  - 14.4.1 DNA Fingerprinting
    - 14.4.1.1 Procedure of DNA Fingerprinting
    - 14.4.1.2 Use of DNA Fingerprinting
    - 14.4.1.3 Disadvantages of DNA Fingerprinting
  - 14.4.2 Enzyme Linked Immunosorbent assay
    - 14.4.2.1 Procedure of ELISA
    - 14.4.2.2 Types of ELISA
    - 14.4.2.3 Uses of ELISA
    - 14.4.2.4 Advantages of ELISA
    - 14.4.2.5 Disadvantages of ELISA

14.5	Transgenic Animals
14.5.1	Methods of production
14.5.2	Ethical concerns
14.5.3	Disadvantages
14.6	Liposomes
14.6.1	Composition, types and production of Liposomes
14.6.2	Mechanism of drug incorporation in liposomes
14.6.3	Uses of Liposomes
14.6.4	Advantages of Liposomes
14.6.5	Disadvantages of liposomes
14.7	Summary
14.8	Glossary
14.9	Self-Learning Exercise
14.10	References

---

## 14.0 Objectives

---

After going through this unit you will be able to understand:

- Humulin and its production,
- Gene therapy (procedure, uses etc.),
- Application of DNA fingerprinting and ELISA in molecular diagnosis,
- Transgenic animals: methods of production and applications,
- Liposomes and their role in biomedical science.

---

## 14.1 Introduction

---

Medical biotechnology is a part of biotechnology that touches the everyday life of individuals. Both wellness and illness have ties to biotechnology. The use of biotechnology in medicine, also known as **red biotechnology**, is growing rapidly and providing opportunities to develop, more effective drugs, effective diagnosis and other therapeutics. The use of biotechnology is thus providing us safer, cheaper medicines and therapeutics. The most important aspect of biotechnology is study of human genetics which helped us to understand what happens when genes go wrong in inherited diseases or cancers and hence to

develop new therapies to treat the genetic cause, not the symptoms. Moreover,genetical studies of viruses, fungi and bacteria, assist us to understand how they cause diseases and develop better drugs and antibiotics that target them more specifically.

Red biotechnology further extends its canvas in developing medicines against diseases like cancer, tumors and AIDS, improving the already existing techniques and drugs in terms of decreased side effects and high specificity. This new level of understanding has, in turn, created opportunities for the development of new therapies, drugs, diagnostic tools and research/clinical instrumentation. Medical biotechnology is among one of the most promising sectors providing fastest growth and employment opportunities.

**Molecular diagnostics** is a technique used to analyze biological markers in the genome and proteome—the individual's genetic code and the way genes express themselves as proteins. This development is a result of application of tools of molecular biology and genetic engineering to medical testing. The technique is used to diagnose and monitor diseases, detect risks and decide which of the therapies will work best for individual patients. Molecular medicine is a broad field, where physical, chemical, biological and medical techniques are used to describe molecular structures and mechanisms, identify fundamental molecular & genetic errors of diseases and to develop molecular processes to correct them. The molecular medicine emphasizes cellular and molecular phenomena and interventions rather than the previous conceptual and observational focus on patients and their organs. Some of the goals of molecular medicine include: Improved diagnosis of disease, Earlier detection of genetic predispositions to disease, Rational drug design, Gene therapy and control systems for drugs, Pharmacogenomic ("custom drugs") etc.

---

## 14.2 Humulin and its production

---

Humulin is a form of insulin (trade name Humulin) made from recombinant DNA identical to human insulin. Humulin is used to treat diabetic patients who are allergic to insulin preparations made from beef or pork insulin. Humulin is chemically, biologically, physically and immunologically equivalent to the human pancreatic insulin.

Insulin is a pancreatic peptide hormone released from  $\beta$  cells of islets of Langerhans which allow our body to use sugar (glucose) in the food and to store glucose for future use. Insulin is responsible for keeping blood sugar level from getting too high (hyperglycemia) or too low (hypoglycemia) i.e. it helps in

maintaining balance of blood glucose level. In fact, body cells need sugar for energy, however, it cannot be absorbed directly by the body cells. After meals as blood sugar level rises,  $\beta$ -cells in pancreas are signaled to release insulin into bloodstream. Insulin then attaches to and signals cells to absorb sugar from the bloodstream. In this way sugar enter in the cell and is used for energy. Insulin also helps to store the excess sugar in liver. When the blood sugar level is low or if body needs more sugar (such as in between meals or during physical activities), the stored sugar is released back in the blood. Therefore, insulin is important to maintain the balance of blood sugar level in a normal range. As blood sugar level rises, the pancreas secretes more insulin. In the absence of sufficient release of insulin or if the body cells become resistant to the effects of insulin (diabetics mellitus type 1), a chronic situation of high blood sugar arises in the body (hyperglycemia).

Insulin is composed of two peptide chains *viz* A chain and B chain (figure 1). A and B chains are linked together by two disulfide bonds (residue A7 to B7 and A20 to B19) and an additional disulfide bond is formed within the A chain (residue A6 to A11). In most species, the A chain consists of 21 amino acids and the B chain has 30 amino acids.

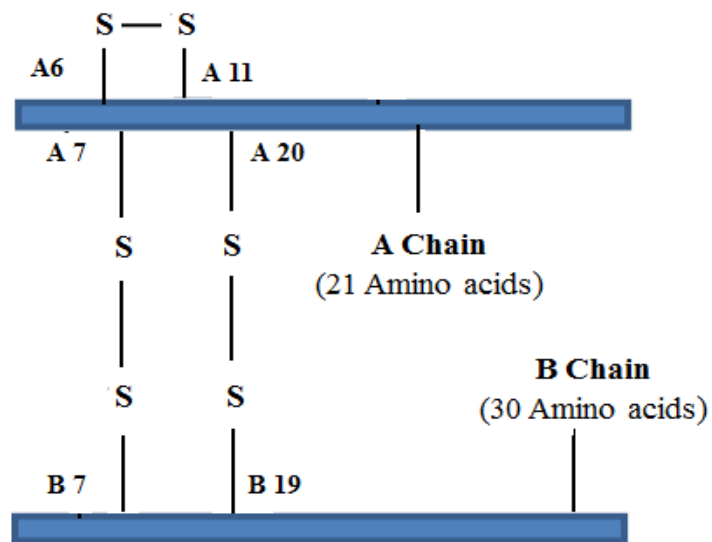

Figure 1: Structure of Insulin

For many years, after the composition and structure of human insulin was elucidated in 1955 and 1969 respectively, insulin was obtained by purifying it from the pancreas of cows and pigs slaughtered for food. This method was expensive, difficult and the insulin so obtained could cause allergic reactions.

Later, the cow and pig insulin was chemically modified to make it same as human insulin. This reduced (up to certain level) the incidences of insulin allergies but raised the cost of production.

#### **14.2.1 Historical perspectives**

Up to 1920 researchers did not know how to produce insulin and hence people who suffered from Type I diabetes had a very little chance for a healthy life. The first report of successful insulin production came in 1921 when two Canadian scientists 'Frederick G. Banting' and 'Charles H. Best' purified insulin from the pancreas of a dog. The chemical structure of insulin in these animals is only slightly different from human insulin, which is why it functions so well in the human body (although some people had negative immune system or allergic reactions). In 1955, Fred Sanger determined its amino acid structure and in 1969, Dorothy Hodgkin used X-ray crystallography to find its three-dimensional structure. For many years scientists made frequent efforts to bring improvements in producing insulin. In 1936, scientists developed a slow release insulin by adding protamine (a fish sperm protein). The protamine-insulin hybrid breaks slowly and hence one dose lasts for 36 hours. In 1950s researchers developed a type of insulin that acted slightly faster and does not remain in the bloodstream for long. In 1970s, investigators produced an insulin molecule that more realistically mimicked the working of body's natural insulin- releasing a small amount of insulin all day with surges occurring at mealtimes.

Scientists continued to work for the improvement of insulin but the basic production method remained same for decades. Insulin was extracted from the pancreas of cattle & pigs and purified. Then in early 1980s, after scientists determined the sequence and exact location of the insulin gene at the top of chromosome 11, biotechnology revolutionized insulin synthesis. By 1977, a research team had introduced a rat insulin gene into a bacterium that then produced insulin.

In the 1980s, scientists used genetic engineering to manufacture human insulin. In 1982, the Eli Lilly Corporation produced a human insulin that became the first approved genetically engineered pharmaceutical product. After the advent of this technology, scientists could produce genetically engineered insulin (free from animal contaminants) in limitless quantities without needing to depend on animals. This human insulin which was produced using genetic engineering was termed as **Humulin**. Use of humulin almost nullified the concerns about

transferring any potential animal disease along with the insulin. From 1980s onwards use of insulin obtained from animals is almost replaced by humulin created through recombinant DNA technology. Now-a day's companies are focusing on synthesizing human insulin and insulin analogs i.e. humulin with some modifications.

#### 14.2.2 Production of Humulin

After the discovery of insulin in 1921 till early 1980's, diabetic patients with elevated sugar levels (due to impaired insulin production) were treated with insulin derived from the pancreas of abattoir animals. Although bovine and porcine insulin are functionally quite similar to human insulin, their composition is slightly different. Consequently, immune system of a number of patient's produces antibodies against it, neutralizing its actions and resulting in inflammatory responses at the site of injection. Furthermore regular injections might result in long term complications. These complications led researchers to synthesize *Humulin* by inserting the insulin gene into a suitable vector followed by insertion into *E. coli* bacterial cell. This led to the production of an insulin molecule which is chemically identical to its naturally produced counterpart. This method of insulin production is a more reliable and sustainable method than the previously established methods.

The genetic code for insulin is found at the top of the short arm of the eleventh chromosome. It contains 153 nitrogen bases (63 in the A chain and 90 in the B chain). Naturally this DNA segment is transcribed to mRNA followed by translation into an amino-acid sequence. It is first synthesized in an inactive form known as preproinsulin. This is a single long protein chain with the A and B chains joined together in the middle by a thirty one amino-acid sequence called C-peptide (A-C-B). A signal sequence is also found at one of the ends. This signal peptide directs the preproinsulin to rough endoplasmic reticulum (RER). The signal peptide gets detached in the lumen of RER giving rise to Proinsulin. In RER, proinsulin is folded into a correct conformation followed by the formation of three disulfide bonds [two inter-chain and one intra-chain (within A chain)]. From RER, proinsulin is transported to Golgi-complex, where C-peptide is cleaved. This cleavage is executed by the action of endopeptidase called **Prohormoneconvertase**. Release of C-peptide leaves mature insulin with A and B chains linked by two disulfide bonds.

**Commercially production:** Synthesizing human insulin is a multi-step biochemical process that depends on basic recombinant DNA techniques and an



understanding of the insulin gene (figure 2). Commercially humulin is synthesized by genetic engineering as below:

- i. DNA coding for A and B polypeptide chains of insulin are chemically synthesized in the laboratory. Sixty three nucleotides are sequenced to produce A chain of insulin and ninety nucleotide long DNA is designed to produce B chain of insulin, plus terminator codon is added at the end of each chain. Anti-codon for methionine is added at the beginning of the sequence to distinguish humulin from the other bacterial proteins.
- ii. Chemically synthesized A and B chain DNA sequence are inserted into one of the marker gene, the *lacZ* gene (*lacZ* gene encodes for  $\beta$ -galactosidase) which is present in the plasmid vector. Restriction enzymes and ligase enzymes are required for the insertion process. *lacZ* genes widely used in recombinant DNA procedures because it is easy to find and cut, allowing the insulin gene to be readily identified so that it does not get lost in host DNA. Next to this gene is the sequence for amino acid methionine.
- iii. The recombinant plasmids with the insulin gene are then introduced into the *E. coli* bacterial cell, in a process called as transformation. During the process of transformation of *E. coli*, the cells are soaked in ice-cold solution of  $\text{CaCl}_2$ . This makes *E. coli* cells competent. The competent cells are then mixed with the plasmid DNA and are incubated in ice for 20-30 minutes followed by short heat shock. Heat shock enables the transfer of DNA into the cell. Finally, the cells are placed in nutrient broth and incubated at  $37^\circ\text{C}$  for 60-90 minutes. This step is important to establish the transformed plasmids. Once these steps are successfully completed, the transformed cells are placed on a suitable media for propagation of cells by mitosis. Along with these cells, recombinant plasmid also gets replicated. These in turn produce insulin.
- iv. The bacteria synthesizing insulin are then subjected to fermentation. They are grown at optimal growth conditions of large tanks in manufacturing plants. The millions of bacteria replicate roughly in every 20 minutes through mitosis and each express the insulin gene. After multiplying, the cells are taken out of the tanks. They are broken open to separate the insulin chains from the rest of cell debris. A and B polypeptide chains of insulin are then extracted and purified in the lab.
- v. The A and B polypeptide chains of insulin are mixed together. They are then connected with each other by disulphide bond through oxidation- reduction reactions, forming the humulin or synthetic human insulin.

vi. The mixture so obtained is purified through several chromatographic separation techniques like ion-exchange column, reverse-phase high performance liquid chromatography and gel filtration chromatography column, etc. to get 100% pure humulin.

In addition to the above classical method of humulin production, two other methods have also been used. One such method is Proinsulin process, in which DNA coding for proinsulin is synthesized. This sequence is then inserted into the plasmid and the recombinant plasmid is then transformed into *E.coli*. The bacteria go through the fermentation process where it reproduces to produce proinsulin. Then the connecting sequence between the A and B chains is spliced away with an enzyme and the resulting insulin is purified.

In the second method, analog insulin is made. Analog is a chemical substance that mimics another substance so well that it fools the cell. Analog insulin clumps less and disperses more readily into the blood. This allows insulin to start working in the body minutes after an injection and is absorbed quickly.

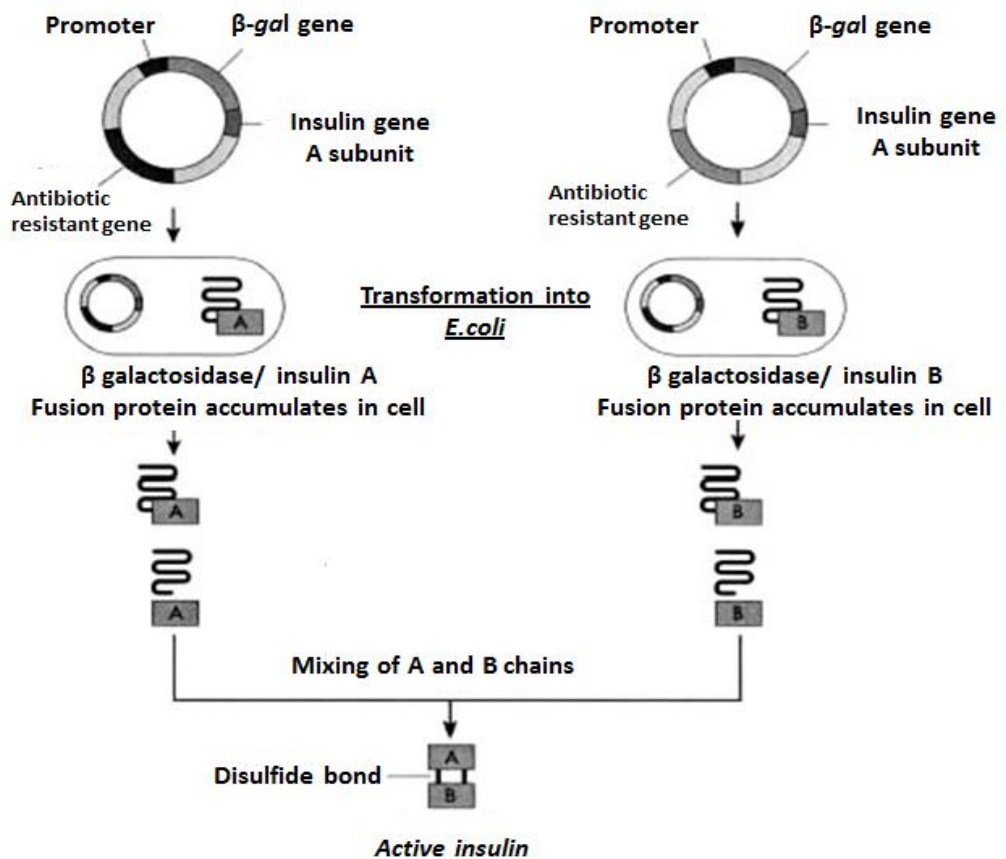

Figure 2: Insulin production

### **14.2.3 Types of humulin**

Depending upon the onset (time required by insulin to start lowering blood sugar), peak (the time period after which the insulin is the most effective in lowering blood sugar) and duration time (how long insulin continues to lower blood sugar), humulin are of five different types *viz*;

- ✓ Rapid-acting
- ✓ Short-acting
- ✓ Intermediate-acting
- ✓ Long-acting
- ✓ Pre-mixed

Which type of insulin is to be administered depends upon individualized response to insulin (time required by insulin to get absorbed in the body and remain active in body varies slightly from person to person) *viz* (a) lifestyle –for instance, the type of food patient take, alcohol intake, extent of exercise done and all other factors that influence body's processing of insulin, (b) willingness towards taking multiple injections per day, (c) frequency and willingness to check blood sugar level (d) age and (e) blood sugar management goals.

### **14.2.4 Advantages of Humulin**

Earlier (before 1980s) insulin required for diabetes was extracted from pancreas of slaughtered cattle, pigs or salmon. The process was quite tedious and difficult. Moreover the yield of insulin was very low. This extracted insulin, in some patients, resulted in development of allergy, autoimmuneresponses and many other side effects. Due to disadvantages of animal insulin and the below listed advantages of humulin, humulin is regarded superior to animal insulin.

- ✓ It is absorbed more rapidly and shows its effectiveness in short duration.
- ✓ It causes fewer allergic and autoimmune reactions as compared to animal insulin.
- ✓ It is less expensive than animal insulin.
- ✓ It can be produced in high quantities at a rapid pace.

It is due to above advantages, now almost all insulin marketed is human insulin.

### **14.2.5 Disadvantages of Humulin**

It has been reported that human insulin may lead to side effects such as hypo unawareness, tiredness and weight increase. Rarely, subcutaneous

administration of insulin may result in lipoatrophy (seen as an apparent depression of the skin) or lipohypertrophy (seen as a raised area of the skin). Patients occasionally experience redness, swelling and itching at the site of injection. This condition, called local allergy may continue for few days to a few weeks. Less common, but potentially more serious, is generalized allergy to insulin, which may cause rashes all over the body, shortness of breath, wheezing, drop of blood pressure, fast pulse and sweating.

---

### **14.3 Gene therapy**

---

Gene therapy can be considered as a treatment strategy that involves the introduction of healthy genes or genetic material into human cells to alleviate or eliminate diseases. In other words, gene therapy is a form of therapy that involves insertion of laboratory version of one or more corrective genes (normal allele) into the genetic material of a patient's cells (who carries faulty gene into the chromosome) to cure a genetic disease with an aim to replace or repress defective genes. The expression of the new gene(s) can alter the DNA or RNA transcript used to synthesis healthy proteins and therefore correct the disease (figure 3). Thus this approach is different from traditional drug-based approaches, which treat symptoms but not the underlying genetic problems. Researchers, in 1990, treated a four year old child for adenosine deaminase (ADA) deficiency by human gene therapy. This was the first successful attempt of gene therapy. ADA is a rare genetic disease in which children are born with severe immunodeficiency and are prone to repeated serious infections. About 4,000 diseases are caused due to genetic disorders. Some of the current and possible diseases that could be treated with gene therapy include cancer, AIDS, cystic fibrosis, Parkinson's disease, Alzheimer's diseases, amyotrophic lateral sclerosis (Lou Gehrig's disease), cardiovascular diseases, arthritis and many more. Gene therapy is likely to be most successful with diseases caused by single gene defects such as cystic fibrosis or hemophilia (table-1), which results from a mutation in a single gene. Diseases like hypertension or high cholesterol are under the control of many genes. Moreover, in these cases, certain genetic factors may interact with environmental stimuli to cause disease. Thus, it is difficult to treat such diseases by gene therapy.

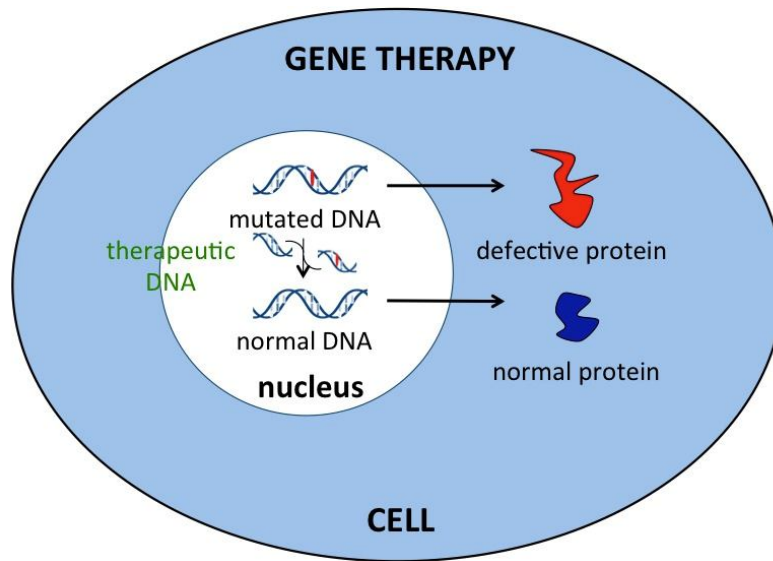

**Figure 3: Gene therapy (functional principle)**

Till now the medical use of gene therapy is in its infancy. The specific delivery of normal genes to the diseased part of the body, replacement of damaged genes and turning on and off specific genes are still beyond reach of the “gene doctors.” However, researchers are testing several approaches for gene therapy, including: (a) replacing a mutated gene that cause disease with a healthy copy (b) Inactivating, or “knocking out,” a mutated gene that is functioning improperly (c) Introducing a new gene into the body to help fight against a disease.

In gene therapy, a gene cannot be inserted directly into a cell because it will not function. Instead genetically engineered carrier called vector is used to deliver the gene. In this process, certain viruses are often used as vectors because they have good potential to deliver the new gene (s) by infecting the cell. The vector may be directly injected or given intravenously into a specific body tissue where it can be taken up by individual cells. Alternately, a sample of the patient’s cells can be removed and exposed to the vector under laboratory conditions. The cells containing the vector are then returned to the patient. If the treatment is successful, the new gene delivered by the vector will make a healthy functional protein.

<b>Disease</b>	<b>Target tissue</b>	<b>Incidence</b>
Thalassaemia	Bone marrow	1 : 600 in some populations
Cystic fibrosis	Liver	1 : 500

Duchenne muscular dystrophy	Muscle/brain	1 : 300 males
Haemophilia A	Liver	1 : 6000 males
Haemophilia	Fibroblasts	1 : 30000 males

**Table: 1** Selected human genetic diseases for possible single-gene therapy

### 14.3.1 Types of gene therapy

For the purpose of gene therapy, two types of possible genetic alterations (figure 4) are being used by the scientists. In one form, called the **somatic cell gene therapy**, changes are introduced into non-reproductive (somatic) cells such as bone marrow, liver etc. Such changes affect only treated individuals and cannot be passed on to their offspring. Somatic cell gene therapy needs to be done for several times in the patient's life because the effects do not last very long. In the second form, called **germ line gene therapy**, alterations are introduced in the reproductive (germ) cells i.e. sperm and ova. Here the altered traits are passed on to the subsequent generations. This type of gene therapy is done once and is permanent. One form of germline therapy is done to treat pre-embryos that carry serious genetic defect(s) followed by placing them back in the mother by *in vitro* fertilization. Another form of germ line therapy is to treat adult sperm and egg cells so the genetic defect is not passed on to children.

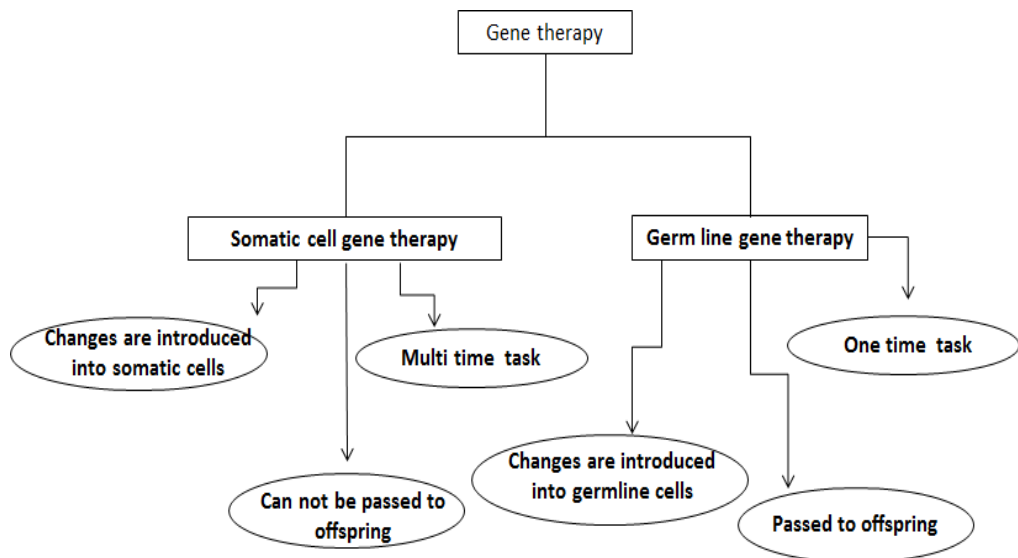

**Figure 4:** Types of gene therapy

### 14.3.2 Procedure of gene therapy

The use of gene therapy for treatment is very expensive, time taking and tedious. Therefore, before making use of gene therapy, this is necessary to make it sure that there is sufficient value in treating the condition or disorder with gene therapy and there is no simpler way to treat it. The following steps are required for to execute gene therapy (Figure 5a and 5b)-

- ✓ Identification of the faulty gene that causes a specific diseased condition. It is important to gather some information about how it results in the condition or disorder. This helps to design the genetically altered vector for use and to target the appropriate cell or tissue. The accurate diagnosis of the genetic defect and location of affected cells is done by using a DNA probe. The DNA probe is a sequence specific to a complementary piece of DNA. Use of DNA probes makes the process more specific than other conventional methods of diagnosing genetic defects in humans.
- ✓ The gene coding for the desired protein is isolated.
- ✓ The gene is delivered to the target cell by means of a vector. This vector, produced by genetic engineering, carries the desired gene into the cell.
- ✓ The gene begins to produce DNA and RNA and ultimately protein in a controllable way.
- ✓ This protein acts inside the cell or is released into the environment and then stimulates the desired action.
- ✓ Sufficient data from cell and animal experiments is collected to make it sure that the procedure itself works well and is safe.

**Vectors used:** To get a new gene into a cell's genome, it must be carried in a molecule called a vector. The most common vectors currently being used are viruses, which can naturally invade cells and insert their genetic material into the cell's genome. Both DNA and RNA viruses can be used as vectors in gene therapy. Viruses are an excellent choice for use as vectors, because they have the ability to avoid destruction by the human immune system and have the capacity to get their own genetic material inside human cells.

To use as vector, viruses are made non-virulent and some of their genes are replaced with the new gene designed for the cell. When virus attacks the cell, it integrates its genetic material (along with the desired gene it is carrying) into

the chromosomal DNA of the host a process called transduction. A successful transfer will result in the target cell carrying the new gene to correct the problem caused by the faulty gene.

Under natural conditions a virus binds to specific surface receptor molecules of cell to gain entry. Viruses have outer envelope proteins that fit perfectly into certain receptors on specific cells. For example, the **murine leukemia virus (MuLV)** virus binds to cells containing a receptor called the **amphotropic receptor**. This is also a fact that a broad range of cell types possess amphotropic receptor. This means that the MuLV virus, in its natural form, can infect all of those cell types which possess amphotropic receptors, (however most of them are likely not the target of the therapy). To make viral vectors more specific about the cells they invade, scientists are working on many approaches. One such approach is **replacing or modifying the outer viral proteins in such a way that** they fit into more specific and rare receptors present upon specific cell types being targeted for gene therapy. Another approach is to **add new proteins** to the outer viral envelope which either better recognize the target cell or better recognize the region of the body where the target cells are located.

Retroviruses are virus of choice. Many retroviruses are not very harmful to the cell i.e. their use poses less risk than the use of some other viruses. Even if something goes wrong and some of the original retrovirus particles are administered to the patient, they will not cause serious problems. The **MuLV** is one of the most popular retroviruses used as a retroviral vector. Adenoviruses are also among the vector of choice for gene therapy. Adenoviruses are DNA viruses that are able to transduce a large number of cell types, including non-dividing cells. They also have capacity to carry long segments of added genetic information. Moreover, it is fairly easy to produce large amounts of adenoviruses in culture. Adenoviruses, in their natural form, are not very harmful, typically causing nothing more serious than common cold in otherwise healthy people. This means that their use as vectors is quite safe. For all these reasons, adenoviruses are the most widely used DNA vectors used for *in situ* gene therapy. **Adenoviral vectors are currently being experimented for the treatment of several cancers and cystic fibrosis.** Among the other virus types being explored as vectors are the **adeno-associated virus (AAV)** and the **herpes simplex virus (HSV)**. Both are DNA-based viruses. AAV integrates its genetic material into a host chromosome and cause no human disease. However being very small AAV cannot accommodate large genes. HSV



vectors do not integrate their genes into the host genome. They tend to target neurons and thus have the potential for use in the treatment of neurological disorders.

There are few advantages of using viral vectors namely-(1) they're very good at targeting and entering cells, (2) some target specific types of cells and they can be modified in such a way that they can't replicate and destroy the host cells. However some drawbacks are also associated with the use of viral vectors like they can carry only limited amount of genetic material. Therefore, larger genes may not fit properly into viruses. They can elicit immune responses in patients and hence can result in problems (a) patients may get sick and (b) immune system may block the virus from delivering the gene to the patient's cells, or it may kill the cells once the gene has been delivered.

Some non-viral vectors are also used. The use of non-viral vectors can involve direct injection of plasmid DNA or mixing plasmid DNA with compounds that allow it to cross the cell membrane and protect DNA from degradation. Other approaches include direct injection of the gene into the cell, or use of liposomes (an artificial fat sphere), or use of antibody-like proteins that can recognize the cell surface. However these methods are currently less efficient than the use of viral vectors.

**Methods of Vector Insertion:** There are three principal ways by which vectors can be administered to carry new genes into target cells. The first is called *ex vivo* somatic gene therapy (Figure 5a), where the target cells are removed from the body, cultured in the laboratory with a vector and re-inserted into the body. This process is usually carried out using blood cells because they are the easiest to remove and return.

The second option, *in situ* somatic gene therapy, occurs when the vector is placed directly into the affected tissue. This process is being developed for the treatment of cystic fibrosis (by direct infusion of the vector into the bronchi of the lungs), to destroy tumor's (eg: brain cancer) and to treat muscular dystrophy.

The third option is *in vivo* somatic gene therapy (Figure 5b), where the vector is injected into the bloodstream and is able to find and insert new genes only into the cells for which it was specifically designed. Although there are presently no *in vivo* treatments available, a breakthrough in this area can make gene therapy a very attractive option for treatment. In this case the vector designed to treat

our hypothetical patient could be injected into a blood vessel in her or his arm and would find its way to the affected brain cells!

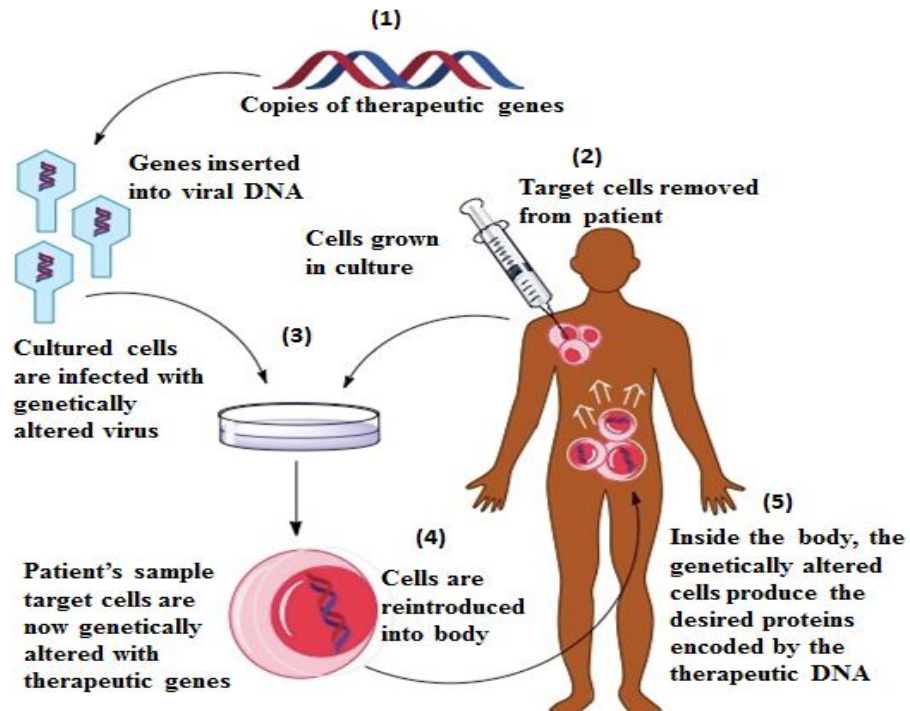

Figure 5a: Procedure of *Ex vivo* gene therapy

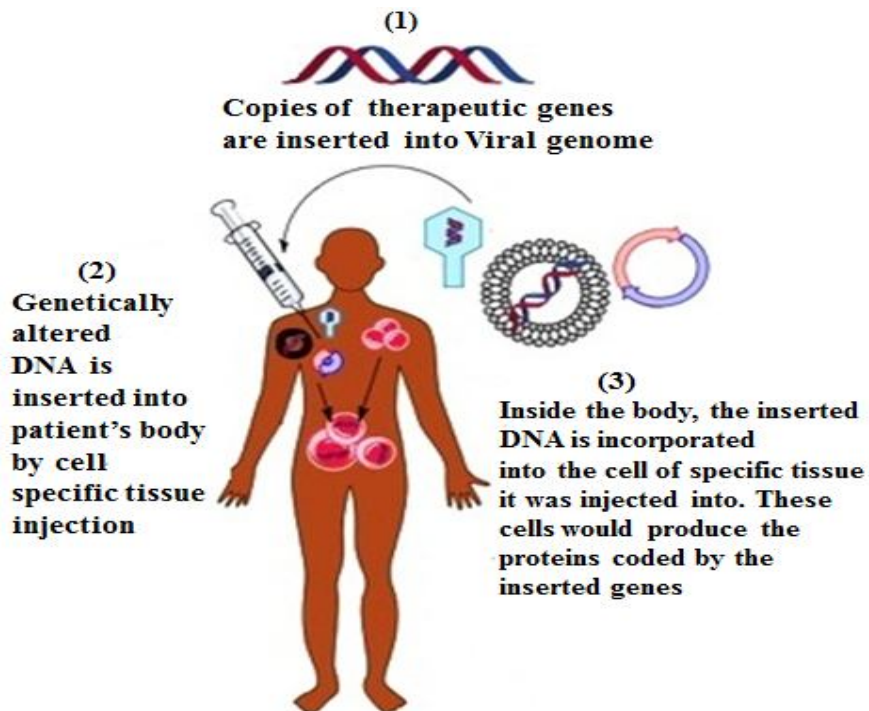

Figure 5b: Procedure of *In Vivo* gene therapy

### **14.3.3 The technological hurdles and risks involved gene therapy**

Some of the risks and hurdles associated with gene therapy are:

- ✓ Gene therapy is short lived. Problems with integrating therapeutic DNA into the genome and the rapidly dividing nature of many cells prevent gene therapy from achieving any long-term benefits. Patients will have to undergo multiple rounds of gene therapy.
- ✓ The immune system may respond against the inserted gene and cause inflammation.
- ✓ In certain cases viral vector, once inside the patient, may recover its ability to cause disease.
- ✓ Many diseases are under the influence of multiple genes sitting at various places. Hence correction of multi genes involves lot of money, hurdles risks and is a tedious process.
- ✓ The therapeutic gene may sit into the wrong spot.
- ✓ The therapeutic gene might produce unregulated amount of missing enzyme or protein, resulting in other health problems.
- ✓ The deactivated virus might target other cells as well.

### **14.3.4 Ethical issues involved**

By far, gene therapy is the most far reaching and controversial therapy involving the processes of genetic engineering. Because gene therapy involves making changes in the setup of body's basic information system, it raises many unique ethical concerns. The government guidelines and consensus in medical community currently forfeit these changes. The ethical questions surrounding gene therapy include:

- ✓ How to distinguish between good and bad gene therapy?
- ✓ Who shall decide which traits are normal and which would constitute a disability or disorder?
- ✓ Will the high costs of gene therapy make it available only to wealthy people?
- ✓ What about social acceptability of widespread use of gene therapy? Whether to allow the use gene therapy to enhance basic human traits such as height, intelligence or athletic ability?

- ✓ The idea of germline gene therapy is controversial. Although it could spare future generations in a family from having a particular genetic disorder, it might affect the development of a fetus in unexpected ways or have long-term side effects that are not yet known. Because people who would be affected by germline gene therapy are not yet born, they can't choose whether to have the treatment or not.

---

## 14.4 Molecular diagnostics

---

The advances in biology have enhanced the understanding of the mechanisms associated with normal and disease processes at molecular level and in turn led to the advent of the field of molecular diagnostics. Molecular diagnostics involve techniques used for **the detection and/or analysis of nucleic acid molecules (DNA or RNA) to provide clinical information**. In other words, it can be understood as the analysis of deoxyribonucleic acid (DNA), ribonucleic acid (RNA), proteins or other metabolites to detect certain genotypes, mutations or biochemical changes that may be associated with certain states of health or disease. Prior to this understanding, many disease states were diagnosed from non-genetic observations. Molecular diagnostic system is more sensitive, specific and simple as compared to traditional diagnostic system.

Molecular diagnostics is rapidly growing field which is used to detect specific sequences in DNA or RNA that may or may not be associated with disease, including single nucleotide polymorphism (SNP), deletions, rearrangements, insertions and others. This technique finds its application in diagnosis & disease monitoring, risk detection and deciding which therapies will work best for individual patients. These tests are useful for a range of medical complications, including infectious diseases, oncology, human leukocyte antigen typing (which investigates and predicts immune function), coagulation and pharmacogenomics.

In general, molecular diagnostics is applied in addressing two distinct types of clinical questions: pathogen detection (searching for exogenous, non-human nucleic acids) and genetic testing (searching for endogenous, host-derived nucleic acids).

Many different biological techniques fall under the umbrella of “molecular diagnostics”. One of the most common techniques is the polymerase chain reaction (PCR) and methods based upon PCR (e.g. DNA fingerprinting), that could be used for pathogen identification and detection of aberrant gene expression(s) associated with certain diseases. Other techniques include

immunological practices like ELISA (Enzyme Linked Immunosorbent Assay), radio immune assay, immune diffusion etc.

#### **14.4.1 DNA Fingerprinting**

Genetic disease testing with DNA fingerprinting is a rapid process that allows medical practitioners to diagnose genetic disorders such as cystic fibrosis, hemophilia and sickle cell anemia. The term "fingerprint" came into use in 1930's when detectives and police use unique fingerprints to catch thieves. Contrary to the conventional fingerprints that are present on the fingertips of an individual, a DNA fingerprint is present in every cell, tissue and organ of an individual. Though fingerprints can be altered using surgery, DNA fingerprints cannot be distorted by any known treatment. It is called a "fingerprint" because it is very unlikely that any two people would have exactly the same DNA. The complete DNA of each individual is unique, with the exception of identical twins. A DNA fingerprint, therefore, is a unique DNA sequence pattern such that it can be distinguished from the DNA patterns of other individuals. DNA fingerprinting is also known as DNA typing.

##### **14.4.1.1 Procedure of DNA fingerprinting**

A common technique used to fingerprint DNA is based upon the variability between several noncoding regions of DNA in genome of individual's, called VNTRs (variable number of tandem repeats). A **hyper-variable number of tandem repeat** (or **VNTR**) is a location in a genome where a short nucleotide sequence is organized as a tandem repeat (A tandem repeat is a short sequence of DNA that is repeated in a head-to-tail fashion at specific chromosomal locus). These regions are composed of a fixed nucleotide sequence which may repeat 2 to 10,000 times. The exact number of repeats is highly variable among individuals. Thus, most individuals are heterozygous because they have inherited a different number of repeats from each parent. Also, it is unlikely that any two unrelated individuals will have the same set of VNTR alleles. In fact, if enough VNTR loci are used, even related individuals can be distinguished. One of the most common DNA fingerprinting procedures is RFLP (Restriction Fragment Length Polymorphism). A more recent form of test is the STR Test (Short Tandem Repeat Test), which counts the number of repeats at a number of different DNA sites.

Nuclear DNA is analyzed for samples containing blood, semen, saliva, body tissues and hair follicles. Mitochondrial DNA however, is usually analyzed in evidence containing hair fragments, bones, and teeth. Moreover, **mitochondrial**

**DNA analysis** can also be performed in cases where sample is present in insufficient amount or the nuclear DNA is uninformative/ distorted or if supplemental information is necessary. Unlike nuclear DNA, where one copy of a **chromosome** comes from the father and the other from the mother, mitochondrial DNA is exclusively inherited from the maternal side. Therefore, the mitochondrial DNA analysis can reveal maternal information.

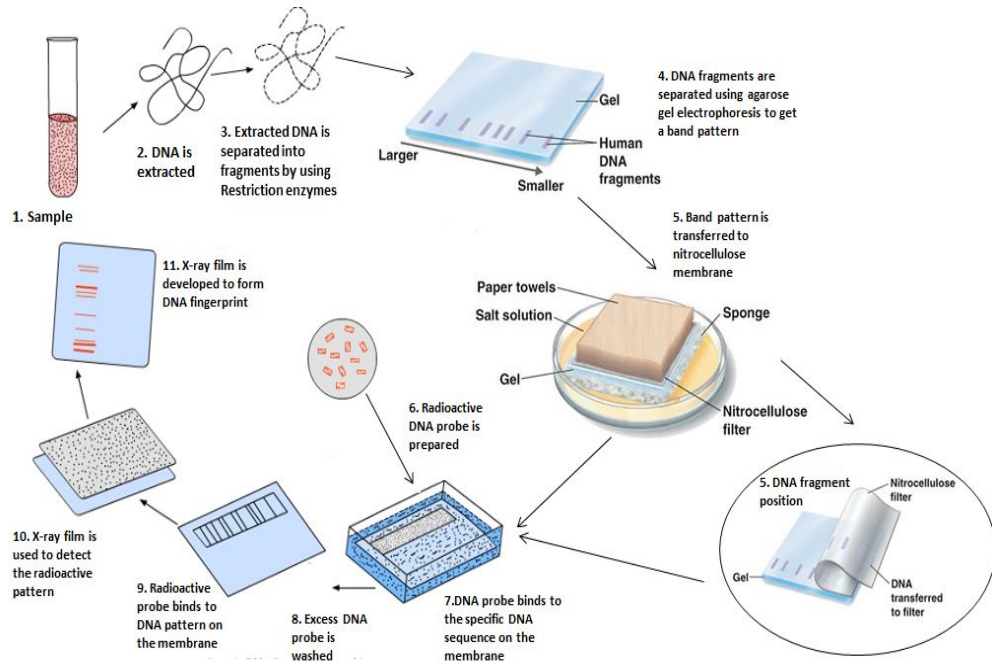

**Figure 6:** Steps involved in DNA fingerprinting

**DNA fingerprinting is a laboratory process that requires following steps (figure 6):**

- ✓ **Isolation of DNA:** DNA is recovered from the cells or tissues. A small quantity of blood, hair or skin is required. DNA is extracted and purified. The DNA has to be separated from the rest of the cellular material in the nucleus. This can be done chemically by using a detergent to wash away extra material from the DNA. In order to separate DNA from other cellular materials, alcohol is added. DNA moves to the alcohol layer and thus it is separated.
- ✓ **Cutting, sizing, and sorting:** Restriction enzymes are used to cut DNA at precise locations. The DNA fragments are then sorted according to their size by electrophoresis. The DNA is poured into a gel and an electric charge is applied to the cell. DNA has a slight negative charge; therefore the

fragments of DNA will get attracted towards the positive charge (opposite charges are attracted to each other). The smaller pieces will move quickly than the larger ones. Thus the DNA will be separated by size. Further by chemical treatment inside the gel, the DNA is rendered as single stranded.

- ✓ **Transfer of DNA to nylon:** The separated DNA fragments are transferred to a nylon sheet by placing the sheet on the gel and soaking them overnight. The process is called as **Southern blotting**.
- ✓ **Hybridization:** Adding colored or radioactive probes (autoradiography) to the nylon sheet creates a pattern called the DNA fingerprint. Each probe generally sticks in only one or two precise locations on the nylon sheet.
- ✓ **DNA fingerprint:** The DNA fingerprint is created using different probes. It looks like the bar codes used by grocery store scanners.

If only a small amount of DNA is available for fingerprinting, a polymerase chain reaction (PCR) may be used to create thousands of copies of a DNA segment. Once an adequate amount of DNA has been produced, the exact sequence of nucleotide pairs in a segment of DNA can be determined using one of the several bio-molecular sequencing methods.

#### **14.4.1.2 Uses of DNA Fingerprinting**

Genetic testing with DNA fingerprinting can be used to inspect genes or markers near the genes. Many disorders, such as Huntington's disease, hemophilia, cystic fibrosis, Alzheimer's disease etc. can be diagnosed using this technique. In addition, thalassemia and sickle cell anemia can also be diagnosed using the same technique.

With the advent of DNA fingerprinting, genetic tests for genetic disorders have far become quick, safer and effectual. This technique is very useful and provides better prevention and treatment prospects for various genetic diseases. Early detection of genetic disorders enables the medical staff to prepare themselves and the parents for proper treatment of the child. Genetic counselors use DNA fingerprint derived information to make prospective parents understand the risk of having an affected child. It can be used to detect if a pregnant women's baby has some genetic disease. In short DNA fingerprinting is done to-

- ✓ Diagnose a disease.

- ✓ Find out person's parents or siblings. This test may also be used to identify the parents of babies who were switched at birth.
- ✓ Solve crimes (forensic science). Blood, semen, skin or other tissue left at the crime spot can be analyzed to prove guilt of the suspect.
- ✓ Identify a dead body. This is useful if the body is badly crumbled or if only body parts are available, such as following a natural disaster or a battle.
- ✓ To determine the likely-hood that an individual will contract certain diseases or cancers.
- ✓ Council parents to make them aware about genetic diseases.

#### **14.4.1.3 Disadvantages of DNA finger printing**

- ✓ DNA fingerprinting is expensive and takes a lot of time. Therefore, it is not very useful for everyday identification purposes.
- ✓ While most experts consider DNA testing accurate, there is always the risk of human error in the results.
- ✓ The procedure is so complex and hard to read the DNA patterns, that sometimes the juror finds the evidence almost invisible.
- ✓ Although DNA Fingerprinting is a highly advanced process, many times it is unable to perform tasks. In dogs for example, a fingerprint does not make it possible to determine if the animal is a carrier of a disease causing allele. Also, a DNA fingerprint is unable to show a crossbreed in animals. This is because second or third generation crosses cannot be seen by working backwards in a pedigree.

#### **14.4.2 Enzyme-Linked Immunosorbent Assay (ELISA)**

Enzyme-Linked Immunosorbent Assay (ELISA) is a solid phase immune assay used to detect substances that have antigenic properties, primarily proteins. The substances detected by ELISA tests include hormones, bacterial antigens and antibodies. This test can be used to determine if patient have antibodies that are related to certain infectious conditions.

ELISA is based on the ability of antigens and antibodies to interact in the solid phase i.e. when one of the two components (the antigen or the antibody) is adsorbed onto the bottom of polystyrene tray, the other component (i.e. either specific antibody or the antigen), if present, binds to the attached



component. All the nonattached substances (nonspecific antibodies, other proteins etc) are removed by vigorous washing. The binding is visualized by attaching a label or tag to the bound component. In simple words, ELISA is a test that uses immunological molecules, enzymes and color change to identify a substance. An enzyme conjugated with an antibody reacts with a colorless substrate to generate a colored reaction product. Such a substrate is called a chromogenic substrate. A number of enzymes have been employed for ELISA, including alkaline phosphatase, horseradish peroxidase and  $\beta$ -galactosidase.

Two independent research groups viz Peter Perlmann and Eva Engvall at Stockholm University and the Dutch research group of Anton Schuurs and Bauke van Weemen, in 1960, formulated the process of ELISA. The assay was based on the underlying principle of radioimmunoassay, with the key difference that the antibodies are labeled with an enzyme, rather than radioisotopes.

This technique combines the antibody specificity along with the enzymes assay sensitivity and use of antibodies or antigens coupled to an easily-assayed enzyme. ELISA can be used to detect the presence of antigens that are recognized by an antibody or it can be used to test antibodies recognized by an antigen. Variations of ELISA allow qualitative detection or quantitative measurement of either antigen or antibody. Alternatively, concentration of antigen/antibody sample can be determined by preparing a standard curve based upon known concentrations of antibodies or antigens.

#### **14.4.2.1 Procedure of ELISA**

A general ELISA is done in following steps (figure 7):

1. An antibody is taken which has the property of binding to a particular antigen.
2. A polystyrene microtiter plate is usually used to immobilize antigen. This plate is made of solid material and is fixed.
3. After the antigen immobilization over a solid surface, primary antibody (e.g. rabbit monoclonal antibody) is added in the reaction. This antibody has the ability to detect the antigen.
4. When the antibody enters the reaction, it finds the antigen, attaches to it and forms a complex.
5. There are two methods of finding the detected antibody. Either an enzyme is used to link to the antibody or a secondary antibody linked to an enzyme through bio-conjugation is used to detect the attached antibody. .

6. During the whole process, the plate is washed regularly with a mild detergent, so that the extra proteins and antibodies can be removed which are not needed for the process.
7. After washing many times, an enzymatic substrate is added in the process so that the presence and quantity of the antigen in the sample can be obtained. This enzyme releases a signal (color etc.) through which detection of quantity of antigen is made possible.

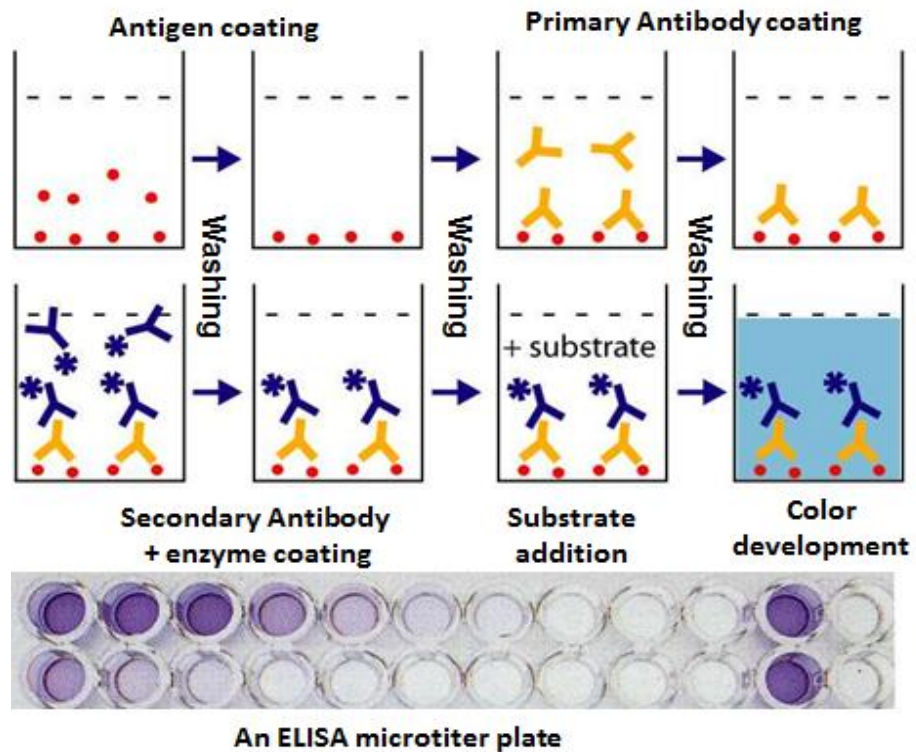

**Figure 7:** Steps involved in ELISA

#### 14.4.2.2 Types of ELISA

ELISA can be classified in four types (figure8):

##### a. *Direct ELISA*

Direct ELISA method detects the presence of an antigen in a particular sample. Specific antibodies to be detected are affixed on the surface of a microtiterplate for holding the sample, usually serum. When sample is placed on the wells, the antigens in the sample bind with the antibodies, forming antigen-antibody complexes. A second antibody linked with an enzyme is then added to the wells. This results in binding of the second antibody with the previously formed Ag-

Abcomplexes. This leads to the activation of the enzyme and when treated with substrate- chromogen complex, produces a change in color. In some cases this results in development of fluorescence.

**b. Indirect ELISA**

An indirect ELISA method detects the presence of an antibody in a sample, usually serum. Serum or some other sample containing primary antibody ( $Ab_1$ ) is added to an antigen- coated microtiter well and allowed to react with the antigen previously attached to the well. After washing off any free antibody, an enzyme-conjugated second antibody ( $Ab_2$ ) is added followed by a substrate to produce a color. The amount of colored reaction product that forms is measured by specialized spectrophotometric plate readers. Indirect ELISA is method of choice used for detection of serum antibodies against many pathogens like human immunodeficiency virus (HIV).

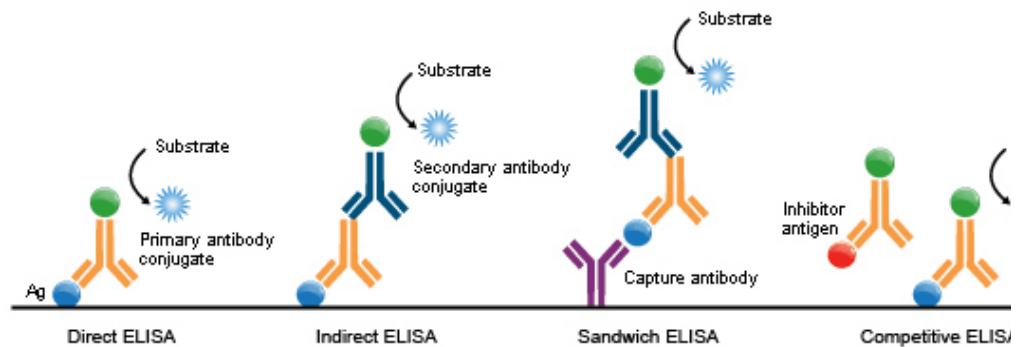

**Figure8:** Types of ELISA

**c. Competitive ELISA**

Another variation for measuring amounts of antigen is competitive ELISA. Antibody is first incubated in solution with a sample containing antigen to form a complex. The antigen-antibody mixture is then added to an antigen coated microtiter well. This complex is brought near the antigen coated surface in the plate. Then a secondary antibody is added which detects this complex. Through a specific signal produced by specific enzyme, this complex can be detected. The unnecessary antigens and antibodies are washed out and the complex is further processed.

**d. Sandwich ELISA**

In this process, the detection of antigen takes place between two plates of antibodies that is why it is called as sandwich ELISA. Antigen can be detected or measured by a sandwich ELISA. In this technique, the antibody (rather than

the antigen) is immobilized on a microtiter well. There should be two binding sites of the antigen so that the two different types of antibodies can attach to the antigen. This type of ELISA is used to quantify the proteins or polysaccharides.

#### **14.4.2.3 Uses of ELISA**

**ELISA could be used for the following:**

1. Detection of serum antibodies.
2. Detection of potential food antigens.
3. Screening of toxicity against drugs.
4. Diagnosis of HIV in blood samples.
5. Detection of *Mycobacterium* antibodies in tuberculosis.
6. Detection of enterotoxin of *E.coli* in faeces.
7. Detection of Rota virus in faeces.

#### **14.4.2.4 Advantages**

1. Quick and convenient
2. High sensitivity and strong specificity.
3. Antigens of very low or unknown concentration can be detected.
4. Generally safe. Do not require radioactive substances, however in some cases diluted sulfuric acid is used.
5. Used in wide variety of tests.

#### **14.4.2.5 Disadvantages**

1. Only monoclonal antibodies can be used. Production of monoclonal antibodies is quite costly.
2. Negative controls may indicate positive results if blocking solution is ineffective [secondary antibody or antigen (unknown sample) can bind to open sites in well]
3. Enzyme-substrate reaction of is short duration. Thus microwells must be read as soon as possible

---

### **14.5 Transgenic Animals**

---

A transgenic animal is a genetically engineered animal that carries a foreign gene deliberately inserted into its genome. As per 'The Federation of European Laboratory Animal Association' the term transgenic animal is defined as an animal whose genetic makeup, responsible for inherited characteristics, has

been deliberately modified. In-fact the mutual contributions of developmental biology and genetic engineering has resulted in the development of techniques which led to the creation of transgenic animals. In this technique, *genes are altered artificially, so that some characteristics of the animal are changed. For example, an embryo can have an extra functional gene artificially introduced into it from another source, or a gene which is introduced to knock out the functioning of some specific gene in the embryo.* Production of transgenic animals is done using germline gene therapy. Germline gene therapy permits the introduction of desired genes into egg cells in a heritable fashion and thus creates future generation of transgenic breeding stocks. Use of germline therapy is however illegal for human use.

It is a costly exercise to produce transgenic animals and a special animal license must be obtained before anyone can make transgenics. Nevertheless, many transgenic animals have been made. The first successful transgenic animal was a mouse developed by Gordon and Ruddle in 1981 using DNA microinjection technique. Later various other species like rabbits, pigs, sheep and cattle's were developed.

The basic reasons for producing transgenic animals are as follows:

- ✓ For the sake of specific economic traits. Transgenic cattle were created to produce milk containing particular human proteins which could help in the treatment of human emphysema.
- ✓ To produce disease models. Transgenics may be useful as animal models for human disease. Animals are genetically manipulated to exhibit disease symptoms so that effective disease treatment can be studied, like for detailed study of disease cystic fibrosis for which no natural model is available. For the same reasons, scientists at Harvard developed a U.S. patented genetically engineered mouse, called OncoMouse® or the Harvard mouse, carrying a gene that promotes the development of various human cancers.
- ✓ Transgenic animals may also be used to determine the role of a specific gene and its protein product. This can be done using gene knock out and then looking at the consequences to the animal. This is useful in cases where we are not sure about the role of a particular protein product.
- ✓ Transgenic animals engineered to study disease symptoms are also used in toxicity testing of new drugs.

- ✓ Animals with specific genetically related anatomical and reproductive problems have been used in the investigations of surgical techniques and reproductive studies respectively.
- ✓ Transgenic animals are also used as models for cancer and for infection. This allow study of susceptible genes and their interactions.
- ✓ Trasgenicsare also used for antibody production
- ✓ Transgenic animals have also been used for production of organs for transplantation surgeries.

#### **14.5.1 Methods of producing transgenic animals**

Production of transgenic animals is being done by three methods (figure9):

- ✓ DNA microinjection
- ✓ Retrovirus-mediated gene transfer
- ✓ Embryonic stem cell-mediated gene transfer

##### ***a. DNA Microinjection***

Gene transfer by microinjection is the predominant method used to produce transgenic farm animals. This is a type of Germline manipulation. Since the insertion of DNA is a random process, transgenic animals are mated to ensure that their offspring acquire the desired transgene. The mouse was the first animal to undergo successful gene transfer using DNA microinjection. This method involves-

- ✓ transfer of a desired gene construct (of a single gene or a combination of genes that are recombined and then cloned) from another member of the same species or from a different species into the pronucleus of a reproductive cell,
- ✓ the manipulated cell is first cultured *in vitro* up to a specific embryonic phase. Afterwards the embryo is transferred to the recipient female

In many cases, the female animal is given drugs to induce superovulation. After she produces eggs, she is allowed either to mate naturally and after 24 hours fertilized eggs could be collected by a method known as **lavage** or the unfertilized eggs could be harvested and fertilized *in vitro* with sperm. The latter method is the most popular one. After fertilization, the egg has two visible pronuclei, the larger female and the smaller male. Using a fine bore needle, the desired DNA is introduced into male pronucleus (figure 9). The needle is made

to penetrate the zonapellucida. About 2pl of DNA is added. The insertion of DNA is however, a random process and there is a high probability that the introduced gene will not insert itself into the desired site on the host DNA. The fertilized transgenic eggs are then transferred to a different female animal. When the offspring's are born, tips of their tails are removed to extract DNA and tested to see whether they are indeed transgenic.

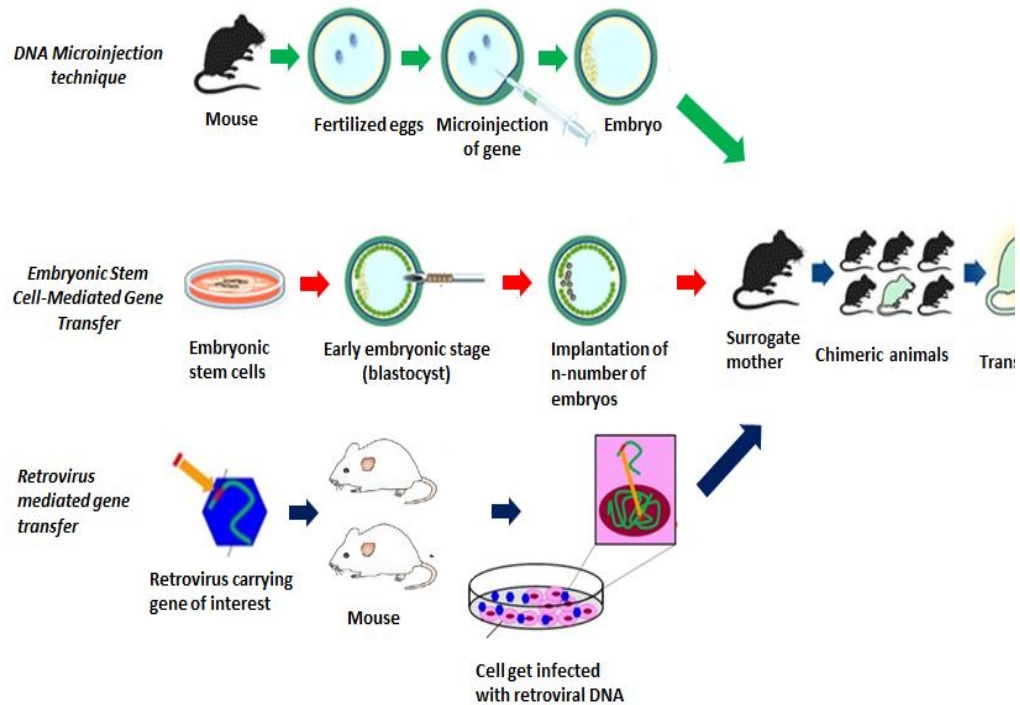

**Figure 9: Techniques of Transgenic animals**

***b. Embryonic Stem Cell-Mediated Gene Transfer***

The Embryonic Stem cell-mediated gene transfer is the method of choice for gene inactivation, i.e. it is a knock-out method. This method involves isolation of totipotent stem cells, which are undifferentiated cells that have the potential to differentiate into any type of cells (somatic and germ cells) and therefore to give rise to a complete organism. Here, the desired DNA sequences are inserted into the genome of embryonic stem (ES) cells cultured *in vitro* by homologous recombination. The cells containing the desired DNA are incorporated into the host's embryo at blastocyst stage of development, resulting in a chimeric animal (figure 9). This technique is of particular importance for the study of the genetic control of developmental processes and works well in mice. It has the

advantage of allowing precise targeting of defined mutations in the gene via homologous recombination. Based on the resultant function of the targeted gene, this method can be used for two lines of investigation: the gene knock-out (KO) to disrupt the existing gene and the gene knock-in (KI) to insert a functional new gene.

Unlike the other two methods, which require live transgenic offspring to test for the presence of the desired transgene, this method allows testing for transgenes at the cell stage.

### ***c. Retrovirus-Mediated Gene Transfer***

In this method gene transfer is mediated by means of a carrier or vector, generally a retrovirus. A retrovirus is a virus that carries its genetic material in the form of RNA rather than DNA. The most important feature of retrovirus as vectors are the technical ease and effectiveness of gene transfer and target cells specificity. When cells are infected by retroviruses, the resultant viral DNA, after reverse transcription and integration, becomes a part of the host cell genome and is maintained for the life of the host cell.

Offspring derived from this method are chimeric, i.e. not all cells are genetically equivalent. Chimeras are inbred for as many as 20 generations until homozygous (carrying the desired gene in every cell) transgenic offspring are born (figure 9). Transmission of the transgene is possible only if the retrovirus integrates into some of the germ cells. There are two major problems associated with this method. One is, the maximum size for reverse transcription of each vector is about 10kb, which may affect the expression level in transgenic animals. Another problem is the recombination, which is production of replication competent retrovirus from virus-producing cells.

### **14.5.2 Ethical concerns**

Transgenic animals raise several moral issues:

- ✓ Is the production of transgenic animals results in an unethical alteration of the natural order of the universe and evolution?
- ✓ Does creating animals by genetic engineering has made animals entirely a commodity?
- ✓ Is it unethical to create diseased animals that are very likely to suffer? Suffering may last for a long time in these animals as researchers may want to conduct long-term investigations to study various aspects of diseases.
- ✓ Should there be universal protocols for transgenesis?



- ✓ What parameters should be considered before permitting research and production of transgenic animals?
- ✓ Is human welfare is the only consideration? What about the welfare of other life forms?
- ✓ Should scientists focus on *in vitro* transgenic methods rather than, or before, using live animals to alleviate animal suffering?
- ✓ Will transgenic animals radically change the direction of evolution (which may result in drastic consequences)?
- ✓ Should patents be allowed on transgenic animals, which may hamper the free exchange of scientific research?
- ✓ Is it unethical to modify an animal's genetic make-up for a specific purpose, without knowing in advance if there will be any side-effects that will cause suffering to the animal?

#### **14.5.3 Disadvantages of transgenic animals**

- ✓ Transgenesis usually leads to breeding problems.
- ✓ Transgenic animals have low survival rate.
- ✓ They can lead to mutagenesis and functional disorders.
- ✓ Pollutant phytase is discharged by transgenic pigs.
- ✓ Development of Transgenic sheep is a difficult and expensive procedure.
- ✓ The whole transgenesis is a very expensive affair.
- ✓ Production of transgenic animals may result in some changes in environmental cycles (insects not being able to eat their usual food and needing to find new food sources).
- ✓ The whole process is quite lengthy.
- ✓ Process may lead to injury to the organism's legs due to being heavier than they are intended to be.
- ✓ Transgenic animals could escape into natural environment (for example, Salmon choose their mate based on body size. If a four hundred pound transgenic salmon fish escapes to the natural environment it would reproduce rapidly. This is bad because transgenic salmon have decreased life expectancies due to decreased swimming ability).

## 14.6 Liposomes

Liposomes are artificially constructed vesicles consisting of a phospholipid bilayer and spherical lipid bilayers capable of entrapping water soluble solutes within an aqueous domain (figure10). In simple words, a **liposome** is a tiny bubble (vesicle), made out of the same material as a cell membrane i.e. phospholipids.

Liposomes can be composed of naturally-derived phospholipids with mixed lipid chains (like egg phosphatidylethanolamine), or of pure surfactant components like DOPE (dioleoylphosphatidylethanolamine). They are biodegradable, biocompatible and nonimmunogenic in nature. These properties make them ideal drug carrier system in therapeutics. Liposomes are also used as models for artificial cells. Liposome can be formulated and processed to differ in size, composition, charge and lamellarity.

Liposomes were discovered in the early 1960's by Bangham and colleague. In 1970s, for the first time, clinical potential of liposomes as a vehicle for replacement therapy in genetic deficiencies of lysosomal enzymes was demonstrated. During 1970-1980, researchers worked to enhance liposomal stability in terms of its circulation time (after intravenous administration). This resulted in improvement of liposome bio-distribution.

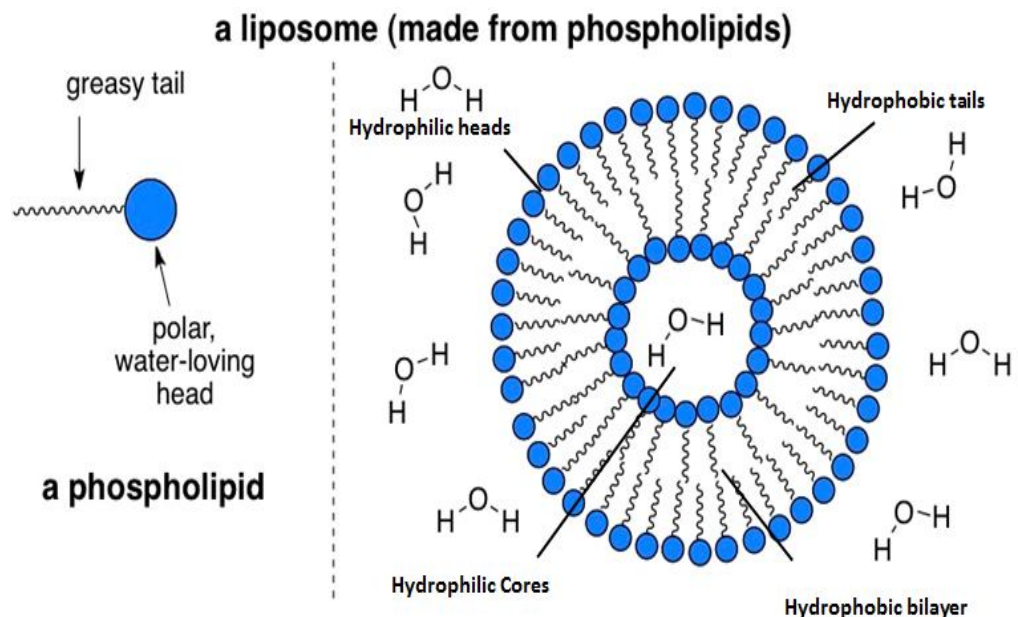

**Figure10:** Liposome

Liposomes have been designed to deliver drugs in different manners (figure 11). Liposomes with low (or may be high) pH can be fabricated in such a manner that dissolved aqueous drugs can be discharged in solution (provided pH is outside the drug's pI range). As the pH naturally neutralizes within the liposome (protons can pass through the membranes), the drug also gets neutralized. This allows drug to pass freely through the membrane. Here drug delivery takes place by diffusion. Another way of liposome drug delivery is associated with endocytosis events. Specific advantage of liposomes is that they can be made in different size ranges. This makes them viable target for macrophage phagocytosis. The liposomes get digested in the macrophage phagosome and in the process release the drug. Sometime liposomes are coated with different opsonins (an opsonin is a molecule that enhances phagocytosis by marking an antigen for an immune response) and ligands to; (a) make endocytosis effective and (b) activate endocytosis in other cell types.

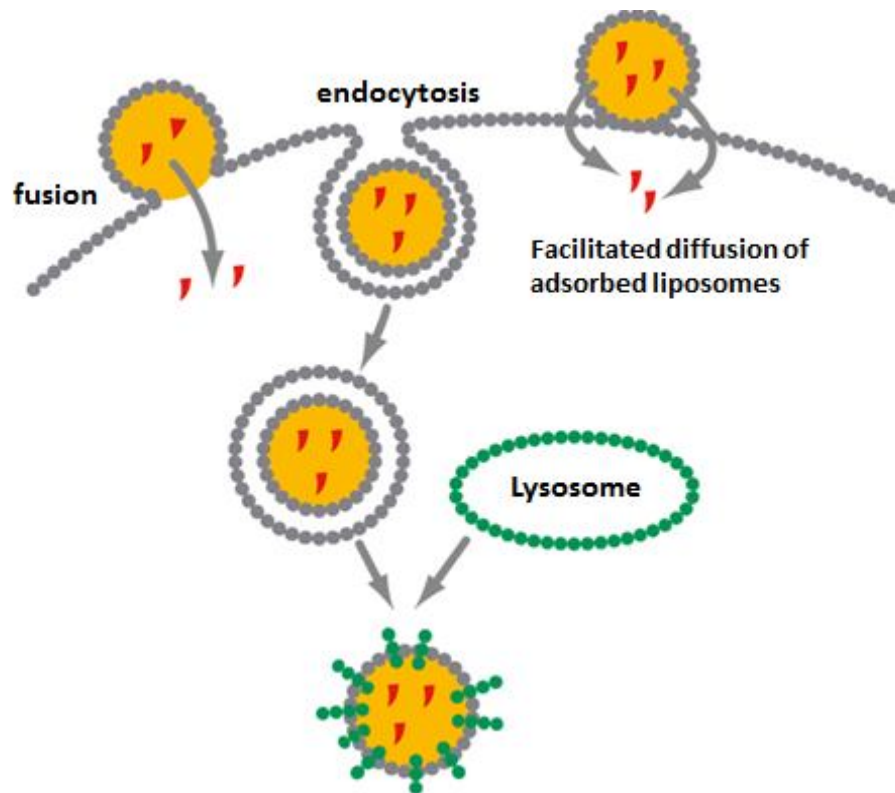

**Figure 11:** Ways of delivery of Liposome contents

### 14.6.1 Composition, types and preparation of Liposomes

#### *a. Composition*

Liposomes are small vesicle of spherical shape. They can be produced from cholesterol, nontoxic surfactants, sphingolipids, glycolipids, long chain fatty acids and sometimes membrane proteins (figure 9). The major structural components of Liposomes are:

- i. **Phospholipids** - Phospholipids are the main component of the liposome's membrane. Both synthetic and natural phospholipids can be used. The most common phospholipid used is known as lecithin (also known as phosphatidylcholine) and is amphipathic.
- ii. **Cholesterol** - Cholesterol molecules in the membrane increases separation between choline head groups which reduces the normal hydrogen bonding and electrostatic interactions.

***b. Classification:***

Depending upon the size and number of Lamellae (lipid bilayers) liposomes can be classified into different types (table 2, figure 12):

<b>Liposome Types</b>	<b>Size</b>	<b>Number of Lamellae</b>
Small Unilamellar Vesicles (SUV)	20 nm - 100 nm	Single
Large Unilamellar Vesicles (LUV)	100 nm - 400 nm	Single
Giant Unilamellar Vesicles (GUV)	1 $\mu\text{m}$ and Larger	Single
Large Multilamellar Vesicles (MLV)	200 nm - $\sim 3 \mu\text{m}$	Multiple
Multivesicular Vesicles (MVV)	200 nm - $\sim 3 \mu\text{m}$	Multiple

Table 2: Types of liposomes

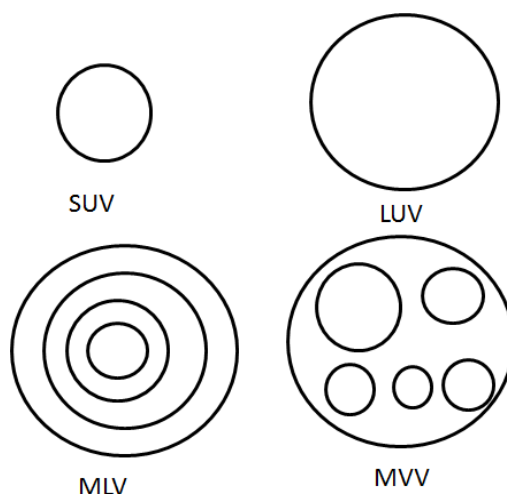

**Figure 12:** Liposome Types

***c. Production:***

The correct choice of liposome preparation method depends on the following parameters:

1. the physicochemical characteristics of; (a) the material to be entrapped and (b) liposomal ingredients
2. the nature of the medium in which the lipid vesicles are dispersed
3. the effective concentration of the substance to be entrapped and its potential toxicity
4. additional processes involved during application/delivery of the vesicles
5. optimum size, polydispersity and shelf-life of the vesicles for the intended application
6. batch-to-batch reproducibility and possibility of large-scale production of safe and efficient liposomal products

Liposomes are frequently synthesized by mixing and dissolving the phospholipids in organic solvents such as chloroform or a chloroform-methanol mixture. A clear lipid film is subsequently formed by removal of the solvent and hydration of this film. This process eventually leads to formation of large, multilamellar vesicles (LMVs). LMV do not allow free interaction of water with the hydrocarbon core of the bilayer at the edges. Once these particles have formed, smaller particles are formed by reducing the size of the particles. This requires energy input in the form of sonic energy (sonication) or mechanical energy (extrusion). In fact just like an onion, an LMV consists of multiple

bilayer complex having several layers. Each of the bilayers is separated by water and sonication disrupts the water layers. This leads to the formation of small, unilamellar liposomes (SUVs). The SUVs, so formed are not very stable and tend to form larger vesicles. They are stored above their phase transition temperature so as to prevent the formation of larger vesicles. Following several freeze-thaw cycles, the lipid suspension is forced through polycarbonate filters containing pores. This results in the formation of liposomes with diameters similar to the size of the pores. Properties of lipid formulations can vary depending on the composition (cationic, anionic and neutral) of lipid species, however, the same preparation method can be used for all lipid vesicles regardless of composition.

#### **14.6.2 Mechanism of drug incorporation in liposomes**

The drugs are introduced into liposomes by three primary mechanisms: encapsulation, partitioning and reverse loading.

##### ***a. Encapsulation***

The physicochemical properties of the drug itself, especially solubility and partition coefficient, are important determinant of the extent of its incorporation in liposomes. It is useful for water-soluble drugs (doxorubicin, penicillin G), the encapsulation is simple hydration of a lipid with an aqueous solution of drug. The formation of liposomes passively entraps dissolved drug in the inter-lamellar spaces, essentially encapsulating a small volume.

##### ***b. Partitioning***

A soluble in organic solvents (cyclosporine) will go through partitioning. It is dissolve along with phospholipid in a suitable organic solvent. This combination is first dried, secondly, added directly to the aqueous phase and finally solvent residues are removed under vacuum. The acyl chains of the phospholipids provide a solubilizing environment for the drug molecule. This gets located in the intra-bilayer space.

##### ***c. Reverse loading***

The reverse-loading mechanism is used for certain drugs (like 5-fluorouracil, mercaptopurine), which may exist in both charged and uncharged forms (depending on the pH of the environment). This type of drug can be added to an aqueous phases in the uncharged state to permeate into liposomes through their lipid bilayers. Then the internal pH of the liposome is adjusted to create a charge on the drug molecules. Once charged, the drug molecule no longer is

lipophilic enough to pass through the lipid bilayer and return to the external medium.

### **14.6.3 Uses of Liposomes**

Liposomes find their major application in drug delivery. Liposomes have also been used for the purpose for transformation/transfection of DNA into a host cell, the process known as **lipofection**. Liposomes are also used as carriers for the delivery of dyes to textiles, pesticides to plants, enzymes and nutritional supplements to foods and cosmetics to the skin. Liposomes have also been used in nano-cosmetology where they provide several advantages including improved penetration & diffusion of active ingredients, selective transport of active ingredients; longer release time, greater stability, reduction of unwanted side effects and high biocompatibility. They are also used as radio-diagnostic carriers, as immunological (Vaccine) adjuvant etc. Liposomes are also used as models for artificial cells.

### **14.6.4 Advantages of Liposomes**

1. Liposomes are biocompatible, completely biodegradable, non-toxic, flexible and nonimmunogenic for systemic and non-systemic administrations.
2. Liposomes supply both, a lipophilic environment and aqueous “milieu interne” in one system and are therefore suitable for delivery of hydrophobic, amphipathic and hydrophilic drugs.
3. Liposomes protect the encapsulated drug from the external environment and hence act as sustained release depots (Propranolol, Cyclosporin).
4. Liposomes can be formulated as a suspension, as an aerosol, or in a semisolid form such as gel, cream and lotion, as a dry vesicular powder (proliposome) for reconstitution.
5. They can be administered through most routes of administration including ocular, pulmonary, nasal, oral, intramuscular, subcutaneous, topical and intravenous.
6. Liposomes could encapsulate not only small molecules but also macromolecules like superoxide dismutase, hemoglobin, erythropoietin, interleukin-2 and interferon's.
7. Liposomes reduce toxicity and increase stability of entrapped drug via encapsulation. (Amphotericin B, Taxol)

8. Liposomes increases efficacy and therapeutic index of drug (Actinomycin-D).
9. Liposome helps to reduce exposure of sensitive tissues towards toxic drugs.
10. Liposomes can alter the pharmacokinetic and pharmacodynamic properties of the drugs (reduced elimination, increased circulation life time).
11. They are flexible to get coupled with site-specific ligands. This results in achieving active targeting (Anticancer and Antimicrobial drugs).

#### **14.6.5 Disadvantages of liposomes**

1. Production cost is high.
2. There are many chances of leakage and fusion of encapsulated drug / molecules.
3. Sometimes phospholipid undergoes reactions like oxidation and hydrolysis.
4. They have short half-life.
5. They have low solubility and stability.

---

### **14.7 Summary**

---

Biotechnology is emerging as one of the most promising fields and will continue to serve mankind for times to come. Biotechnology finds its application in almost everything which affects human life like medical, agriculture, food etc. Use of biotechnology has revolutionized the field of medical science (red biotechnology), especially the drug discovery, drug delivery and treatment processes. The human insulin production by genetic engineering is one such product which has transformed the lives of diabetic patients. Use of humulin has reduced the frequency of allergic and autoimmune reactions as compared to the previous versions of insulin. Another tool of medical biotechnology, the gene therapy has enabled doctors to correct diseases at gene level. Medical practitioners can now use gene therapy for the treatment of many diseases like thalassemia, hemophilia etc.

The revolution of red biotechnology has further extended into diagnostics. Many diseases which were previously difficult to diagnose can now be readily diagnosed by using tools of molecular biology and immunology. Two such tools are DNA finger printing and ELISA. These days, researchers are working on transgenic animals and liposomes for extensive study of diseases and drug delivery system, respectively. Transgenic animals are being used in meeting



various economical needs of human. The detailed study of role of genes has become possible by the use of transgenic animals. Liposomes, being biocompatible and biodegradable, have made a revolutionary change in the drug delivery process. Now-a-days, liposomes have become object of choice for delivery of hydrophobic, hydrophilic and amphipathic drugs.

---

## 14.8 Glossary

---

- **Biotechnology:** Biotechnology is the use of biological processes, organisms, or systems to manufacture products intended to improve the quality of human life. Biotechnology can be broken down into sub-disciplines called red, white, green and blue. Red biotechnology involves medical processes, White (also called gray) biotechnology involves industrial processes such as the production of new chemicals or the development of new fuels for vehicles. Green biotechnology applies to agriculture and involves such processes as the development of pest-resistant grains or the accelerated evolution of disease-resistant animals. Blue biotechnology, encompasses processes in marine and aquatic environments..
- **DNA Fingerprinting:** DNA fingerprinting or genetic fingerprinting is applied to the scientific process whereby samples of DNA are collected and used to match other samples of DNA, which may have been found at the scene of a crime.
- **Embryonic stem (ES) cells:** Undifferentiated cell lines derived from early embryos that have the potential to differentiate into all types of somatic cells as well as to form germ line cells and hence whole animals. Embryonic stem cells are pluripotent, meaning they are able to grow and differentiate into all derivatives of the three primary germ layers: ectoderm, endoderm and mesoderm.
- **Gene Therapy:** Gene therapy is the use of DNA as a drug to treat disease by delivering therapeutic DNA into a patient's cells.
- **Genetic engineering:** Combination of applied techniques of genetics and biotechnology, used to cut up and join together genetic material (especially DNA) from one or more species of organism and to introduce the results into an organism so as to change one or more of its characteristics.

- **Germline cells:** Cells that contain inherited material that comes from the eggs and sperm and that are passed on to offspring.
- **Humulin:** Humulin is form of insulin (trade name Humulin) made from recombinant DNA that is identical to human insulin. It is used to treat diabetic patients who are allergic to preparations made from beef or pork insulin.
- **Lipofection:** Lipofection is the use of liposomes for the purpose for transformation/transfection of DNA into a host cell.
- **Liposomes:** Liposomes are colloidal, vesicular structures composed of one or more lipid bilayers surrounding an equal numbers of aqueous compartments.
- **Microinjection:** The introduction of DNA (or other liquid substances) into the nucleus of an oocyte, embryo, or other cells by injection through a very fine glass micropipette.
- **Transfection:** *It* is the process of deliberate introduction of nucleic acids into cells. The term is often used for non-viral methods in eukaryotic cells.
- **Transgenic Animals:** Animals containing genes altered by insertion of DNA from an unrelated organism. Genes are taken from one species and inserted into another species so as to get that trait expressed in the offspring.
- **Variable number of tandem repeats:** A variable number tandem repeat (or VNTR) is a location in a genome where a short nucleotide sequence is organized as a tandem repeat. These can be found on many chromosomes and often show variations in length between individuals. It is a kind of molecular marker that contains sequences of DNA that have end-to-end repeats of different short DNA sequences.
- **Transduction:** It is a process of genetic recombination in bacteria in which genes from a host cell (a bacterium) are incorporated into the genome of a bacteriophage and then carried to another host cell when the bacteriophage initiates another cycle of infection.

---

## 14.9 Self-Learning Exercise

---

### Section -A (Very Short Answer Type)

1. Who purified insulin for the first time?
2. Define red biotechnology.
3. What are VNTRs?
4. What is full form of ELISA?
5. DNA microinjection is a technique used for the production of.....?
6. Who discovered liposomes?
7. What are the criteria for Liposome classification as LUV, MUV etc?
8. Name the two types of gene therapies.
9. Write full form of SNP.
10. How many types of ELISA are there? Name them.

### Section -B (Short Answer Type)

1. Write short notes on types of ELISA
2. Discuss applications of biotechnology in disease diagnosis.
3. Enlist advantages and disadvantages associated with humulin.
4. Why are transgenic animals important?
5. Explain the process of liposome formation.

### Section -C (Long Answer Type)

1. Write an explanatory note on humulin.
2. Write a detailed note on gene therapy.
3. (a) What are liposomes? Write their uses.  
(b) Discuss different types of ELISA.
4. Discuss the process of DNA fingerprinting in detail. Give a detailed account of its applications.
5. What are transgenic animals? Discuss their advantages and disadvantages. Also add a short note on ethical issues concern with them.

### Answer Key of Section-A

1. Frederick G. Banting and Charles H. Best
2. The use of biotechnology in medicine is known as red biotechnology.
3. A variable number of tandem repeat is a location in a genome where a short nucleotide sequence is organized as a tandem repeat
4. Enzyme linked immunosorbent assay
5. Transgenic animals.

6. Bangham and colleague
7. Size and number of Lamellae (lipid bilayers)
8. Somatic cell gene therapy and germ cell gene therapy
9. Single nucleotide polymorphism
10. Four. Direct, indirect, competitive and sandwich.

---

## 14.10 References

---

- Abdus S., Sultana Y., Aqil M. (2007). Liposomal Drug Delivery Systems: An Update Review. *Current Drug Delivery*.4:297-305.
- Betteridge K. J. (2003). A history of farm animal embryo transfer and some associated techniques. *AnimReprod Sci.* 79, 203–244.
- Bolon B. (2004). Genetically engineered animals in drug discovery and development: a maturing resource for toxicologic research. *Basic ClinPharmacolToxicol.* 95:154–161.
- Camper S. A., Saunders T. L., Kendall S. K. et al. (1995). Implementing transgenic and embryonic stem-cell technology to study gene-expression, cell-cell interactions and gene-function. *Biol. Reprod.*52:246–257.
- Capecchi M. (1989). The new mouse genetics: altering the genome by gene targeting. *Trends Genet.* 5:70–76.
- Chaible L.M., Corat M. A., Abdelhay E., Dagli M. L. (2010). Genetically modified animals for use in research and biotechnology. *Genet Mol Res.* 9:1469–1482.
- Chaize B., Colletier J.P., Winterhalter M., Fournier D. (2004). Encapsulation of enzymes in liposomes: High encapsulation efficiency and control of substrate permeability. *Artif Cells Blood SubstitImmobilBiotechnol.* 32 (1): 67–75.
- Clarke A. R., (1994). Murine genetic models of human disease. *Curr. Opin. Genet. Dev.*4:453–460.
- Crowther J. (2000). The ELISA Guidebook. Humana Press; 2<sup>nd</sup> Ref. Ed edition.
- Einsiedel E.F. (2005). Public perceptions of transgenic animals. *Rev. sci. tech. Off. int. Epiz.* 24(1), 148-157.
- Fischer A., Hacein-Bey-Abina S., Cavazzana-Calvo M. (2010). 20 years of gene therapy for SCID. *Nat. Immunol.* 11 (6): 457–460.

- Gomezzens A., Fernandezromero J. (2006). Analytical methods for the control of liposomal delivery systems. *TrAC Trends in Anal. Chem.* 25 (2): 167.
- Houdebine L. M. (2003). *Animal Transgenesis and Cloning*. Wiley and Sons, London.
- Houdebine L.M. (2005). Use of transgenic animals to improve human health and animal production. *Reprod Dom Anim.* 40:269–281.
- Johnson M. (1998). Cloning humans? *Bioessays*.19:737–739.
- Lequin R. (2005). Enzyme immunoassay (EIA)/enzyme-linked immunosorbent assay (ELISA). *Clin. Chem.* 51 (12): 2415–8.
- Lin J. H. (2008) Applications and limitations of genetically modified mouse models in drug discovery and development. *Curr Drug Metab.* 9:419–438.
- Long X., Miano J.M. (2007). Remote control of gene expression. *J Biol Chem.* 282:15941–15945.
- Mavilio F., Ferrari G. (2008). Genetic modification of somatic stem cells. The progress, problems and prospects of a new therapeutic technology. *EMBO Rep.* 9 Suppl 1: S64–9.
- Meure L. A., Knott R., Foster N. R., Dehghani F (2009). The depressurization of an expanded solution into aqueous media for the bulk production of liposomes. *Langmuir: the ACS journal of surfaces and colloids.* 25 (1): 326–37.
- Pennisi E. (1998). After Dolly, a pharming frenzy. *Science*.279:646–648.
- Pfeifer A. (2006). Lentiviraltransgenesis – a versatile tool for basic research and gene therapy. *Curr Gene Ther.* 6:535–542.
- Vannucci L., Lai M., Chiuppesi F., Ceccherini-Nelli L., Pistello M. (2013). Viral vectors: a look back and ahead on gene transfer technology. *New Microbiol.* 36 (1): 1–22.

**Web sources:**

1. <http://www.britannica.com/EBchecked/topic/167155/DNA-fingerprinting>.
2. <http://www.news-medical.net/health/Liposome-Research.aspx>.
3. [www.biology.arizona.edu › immunology › activities › elisa](http://www.biology.arizona.edu/immunology/activities/elisa).

4. <http://www.abdserotec.com/an-introduction-to-elisa.html>.
5. <http://www.csun.edu/~hcbio027/biotechnology/lec14/lec14.html>.
6. [www.ncbi.nlm.nih.gov](http://www.ncbi.nlm.nih.gov) › *NCBI* › *Literature* › *Bookshelf*.
7. [http://en.wikibooks.org/wiki/Structural\\_Biochemistry/Proteins/Enzyme\\_Linked\\_Immunoabsorbent\\_Assay\\_%28ELISA%29](http://en.wikibooks.org/wiki/Structural_Biochemistry/Proteins/Enzyme_Linked_Immunoabsorbent_Assay_%28ELISA%29).
8. <http://www.pi.lilly.com/humulin-r-ppi> PV 5695 AMP. *Patient Information Humulin<sup>®</sup> R*.

# Unit - 15

---

## Molecular mapping of Genome

---

### Structure of the Unit

- 15.0 Objectives
- 15.1 Introduction
- 15.2 Molecular mapping of genome
  - 15.2.1 Genetic Maps
  - 15.2.2 Physical Maps
- 15.3 Southern Hybridization
- 15.4 Fluorescent In Situ Hybridization
- 15.5 Molecular Markers
  - 15.5.1 RFLP
  - 15.5.2 RAPD
  - 15.5.3 AFLP
- 15.6 Summary
- 15.7 Glossary
- 15.8 Self-Learning Exercise
- 15.9 References

---

### 15.0 Objectives

---

After going through this unit you will be able to understand

- Molecular mapping of genome
- Southern Hybridization
- Fluorescent In Situ Hybridization
- Molecular markers

---

### 15.1 Introduction

---

Genome maps are the location of specific features on the chromosomes of an organism. They are essential elements in identifying genes, which are responsible for several diseases or traits. By contrast, studying the human

genome is actually a two-pronged effort, aiming at both a comprehensive genome map and a complete genome sequence. Advances in sequencing help the mappers move ahead, and advances in mapping help the sequencers make progress. These efforts are closely linked but not exactly the same thing. A sequence is pretty much featureless: just a long, long string of DNA bases or "letters." For the most part, scientists can't look at a sequence and see immediately which parts are genes or other interesting features, and which parts are "junk." But the landmarks on a genome map provide clues about where the important parts of the genome sequence can be found.

An optical mapping technique, FISH enables the position of a marker on a chromosome or extended DNA molecule to be directly visualized. In optical mapping the marker is a restriction site and it is visualized as a gap in an extended DNA fiber. In FISH, the marker is a DNA sequence that is visualized by hybridization with a fluorescent probe.

The techniques of DNA cloning and restriction enzyme analysis have been combined to create a powerful new method used in genetic mapping. In this method, the variation of restriction-enzyme target sites within a species provides large numbers of molecular "alleles," called molecular markers, for chromosome mapping. Such markers are detected by probing with cloned DNA fragments. The ability to detect such molecular markers in large numbers has revolutionized mapping in most organisms, including humans. In a geographic map markers are recognizable components of the landscape, such as rivers, roads and buildings. Mapped features that are not genes are called DNA markers. As with gene markers, a DNA marker must have at least two alleles to be useful. There are three types of DNA sequence feature that satisfy this requirement: restriction fragment length polymorphisms (RFLPs), simple sequence length polymorphisms (SSLPs), and single nucleotide polymorphisms (SNPs). RAPD based on PCR and AFLP based on restriction cutting and PCR.

---

## 15.2 Molecular mapping of Genome

---

Genes are the basic physical and functional units of heredity. A gene is a specific sequence of nucleotide bases, whose sequences carry the information required for constructing proteins, which provide the structural components of cells and tissues as well as enzymes for essential biochemical reactions.

Every organism possesses a **genome** that contains the biological information needed to construct and maintain a living example of that organism. Most



genomes, including the human genome and those of all other cellular life forms, are made of DNA (deoxyribonucleic acid) but a few viruses have RNA (ribonucleic acid) genomes. DNA and RNA are polymeric molecules made up of chains of monomeric subunits called nucleotides. So, the genome is the genetic material of an organism which includes both the genes and the non-coding sequences of the DNA/RNA.

### **Comparative Sequence Sizes (Bases):**

- *Escherichia coli* (bacterium) genome **4.6 Million**
- Entire yeast genome **15 Million**
- Entire human genome **3 Billion**

A **genetic map** is simply a representation of the distribution of a set of *loci* within the genome.

A **genome map**, defines the relative positions of features that are of interest, or which can serve as reference points for navigation. The features that are located on a genome map are collectively referred to as markers, and can include both genes and non coding sequences. The ultimate goal of mapping is to identify the gene(s) responsible for a given phenotype or the mutation responsible for a specific variant.

The initial steps in mapping are to:

1. Establish the proximity of genes or traits to one another
2. Assign the genes to a particular chromosome

The landmarks on a genome map might include short DNA sequences, regulatory sites that turn genes on and off, and genes themselves. Often, genome maps are used to help scientists find new genes.

Molecular mapping can be of following two types.

#### **1. Genetic maps**

#### **2. Physical maps.**

**Both genetic and physical maps provide the likely order of items along a chromosome.**

##### **1.2.1 Genetic maps**

**Genetic maps** (linkage maps) depict relative positions of loci based on the degree of recombination. This approach studies the inheritance/assortment of

traits by genetic analysis. This map also serves to guide a scientist toward a gene, just like an interstate map guides a driver from city to city.

Genetic maps are based on genetic techniques to construct maps showing the position of genes and other sequence features on genome.

Genes on the same chromosome are described as **linked** or **syntenic**.

- Humans have 24 linkage groups, corresponding to the 22 autosomes, plus X and Y chromosomes.
- Groups of genes that are widely separated on a chromosome may show independent assortment; however, all such groups can eventually be tied together by mapping additional loci between them.

The genes on a chromosome can be represented as a single linear structure that goes from one end of the chromosome to the other.

**Genetic distance** is measured by frequency of crossing over between loci on the same chromosome.

One **map unit** = one **centimorgan (cM)** = 1% recombination between loci. The farther apart two loci are, the more likely that a crossover will occur between them. Conversely, if two loci are close together, a crossover is less likely to occur between them.

Recombination can only be detected between two loci, both of which are heterozygous.

- The dominant/recessive relationships must allow for detection of recombinants.
- The most useful systems involve co-dominant alleles.
- Efficient mapping requires **polymorphic** loci, i.e. loci with two or more common alleles. Loci that have a single common allele are described as **monomorphic**.
- Any variations in DNA, whether in coding regions of genes or in non coding regions, can be used as **genetic markers**, i.e. as a label for a particular point on a chromosome.

If two loci are very far apart, two or more crossovers may occur.

- Even numbers of crossovers restore the original combinations of alleles and are counted as zero crossovers.
- Odd numbers of crossovers create recombinant allelic combinations and are counted as one crossover.

- A recombination rate of 50% corresponds to independent assortment. Therefore, only distances less than 50 map units can be measured directly. Greater distances can be constructed by adding up distances between closer loci.

Closely linked genes show association of alleles within families but not necessarily within populations. Crossing over generates random **haplotype** combinations within populations. If the loci are very close together, equilibrium among the possible combinations may take many generations.

If two loci are linked, the alleles that are on the same chromosome are described as **coupled**; alleles on opposite homologous chromosomes are in **repulsion**.

#### **Limitations to construct genetic maps:**

- Access to polymorphic traits or markers
- Need for a large number of progeny and/or multiple generations
- Best performed in model organisms subject to selective breeding
- Crossing over does not occur at random (maps of limited accuracy).

#### **15.2.2 Physical maps**

**Physical maps** show the actual (physical) distance between loci (in nucleotides). This approach applies techniques of molecular biology. **These maps** also mark an estimate of the true distance, in measurements called **base pairs**, therefore, allows a scientist to more easily home in on the location of a gene.

Physical maps use molecular biology techniques to examine DNA molecules directly in order to construct maps showing the position of sequence features, including genes.

Physical mapping can be divided into general types:

1. Restriction mapping
2. **Chromosomal or cytogenetic mapping**
3. Somatic mapping
4. **Radiation hybrid (RH) mapping**
5. **Sequence mapping.**

**Restriction mapping** is one of the oldest techniques of gene mapping based on cleavage by restriction enzymes. These enzymes cut the DNA at specific sites

which are often palindromic sequences of DNA. The mapping is done by identification of relative position of these restriction sites along a linear or circular DNA.

**Cytogenetic mapping** depict the order and map location in reference to a chromosomal banding pattern. The map visualizes the stained chromosomes as seen under a microscope and hence comparison is easier with the homologous chromosomes. The light and dark bands allow the karyotyping of these chromosomes and therefore chromosomal alterations are easier to be identified. **Somatic cell mapping** uses rodent cells to integrate the genome from other species. The technique is used to map a gene to the specific portion of the chromosome with the highest resolution. Target genome cells are fused with the rodent cells and screened for the presence of hybrids with the target genome incorporated. Finer mapping with higher resolution is possible if the hybrids contain cells partial chromosomes as a result of translocation of genome. The process is costlier since it involves screening of numerous hybrids.

**Radiation hybrid mapping** is a cost-effective and high-resolution alternative method of gene mapping. The principle is the same as the somatic cell hybrid mapping. The comparison of results from various groups is relatively difficult. The data is usually in vector format with 1 or + depicting retention of target genome, 0 or - for absence, 2 or '?' for unknown genome.

**Sequences mapping** The different types of maps vary in their degree of **resolution**, that is, the ability to measure the separation of elements that are close together.

- **Sequence tagged site (STS)** mapping is another physical mapping technique. An STS is a short DNA sequence that has been shown to be unique. To qualify as an STS, the exact location and order of the bases of the sequence must be known, and this sequence may occur only once in the chromosome being studied or in the genome as a whole if the DNA fragment set covers the entire genome.

#### **Common Sources of STSs**

**Expressed sequence tags (ESTs)** are short sequences obtained by analysis of complementary DNA (cDNA) clones. They represent the sequences of the genes being expressed. An EST can be used as an STS if it comes from a unique gene and not from a member of a gene family in which all of the genes have the same, or similar, sequences.

**Simple sequence length polymorphisms (SSLPs)** are arrays of repeat sequences that display length variations.

- To map a set of STSs, a collection of overlapping DNA fragments from a chromosome is digested into smaller fragments using **restriction enzymes**, agents that cut up DNA molecules at defined target points and "**molecular cloning**" is carried out.
- The data from which the map will be derived are then obtained by noting which fragments contain which STSs. To accomplish this, scientists copy the DNA fragments using a process known
- Cloning involves the use of a special technology, called **recombinant DNA technology**, to copy DNA fragments inside a foreign host.
- First, the DNA fragments are united with a carrier also called a **vector**. After introduction into a **suitable host**, the DNA fragments can then be reproduced along with the host cell DNA, providing unlimited material for experimental study.
- An unordered set of cloned DNA fragments is called a **library**.
- Next, the **clones**, or copies, are assembled in the order they would be found in the original chromosome by determining which clones contain overlapping DNA fragments.
- This assembly of overlapping clones is called a **clonecontig**.

**Genome mapping has important applications.**

- It is useful for locating the position of genes on chromosomes, e.g. if two genes are closely linked and the position of one is known, then the other must also be nearby.
- It is useful in estimating genetic risk, e.g. if a gene cannot be tested directly, then variation at a closely linked locus may indicate the presence or absence of a detrimental allele.

A major goal of the Human Genome Project is the mapping of all human genes (as well as those of mice, *Drosophila*, *Caenorabditis elegans* (a nematode), *Arabidopsis thaliana* (a small plant), yeast, and the bacterium *Escherichia coli*. As of 1999, yeast, *E. coli*, *C. elegans*, and about a dozen other bacteria have been completely sequenced and all their genes identified, although the functions of most are unknown. Major progress has been made in mapping human genes,

and a "rough draft" of the human genome is anticipated by 2000. Understanding of function of the many newly discovered human genes is being greatly aided by the studies of yeast, which has many genes similar to those of humans

---

### **15.3 Southern Hybridization**

---

The name of this technique is derived from the following:

- (1) The name of its inventor, E.M.Southern, and
- (2) The DNA-DNA hybridization that forms its basis.

The techniques used to detect desired DNA from cells by blotting on nitrocellulose filter membrane is called southern blotting. This technique was invented by E.M.Southern in 1975. This method was later slightly modified in 1979 to detect recombinants from non- recombinants.

This technique has since been extended to the analysis of RNA (*northern blotting*) and proteins (*western blotting*); the names are only jargon terms. *i.e.* reverse of southern being northern and so on, and do not reflect any functional or historical significance.

In southern hybridization, a sample of DNA containing fragments of different sizes is subjected to electrophoresis using polyacrylamide or agarose gel. The DNA sample may either be subjected to mechanical shearing or to restriction endonuclease digestion in order to generate the fragments. Agarose gel is useful in separating DNA fragments of few hundred to 20 kb in size, while polyacrylamide is preferred for smaller fragments. Very large DNA fragments of up to 1000-2000 kb are separated in agarose gel with pulsed electrical fields, or field inversion.

The gel provides a complex network of polymeric molecules through which DNA fragments migrate, depending on their sizes, under an electric field since DNA molecules are negatively charged. Smaller molecules of DNA migrate relatively faster than the larger ones. Marker DNA fragments of known sizes are run in a separate lane; this permits an accurate determination of the size of an unknown DNA molecule by interpolation. The gels are stained with the intercalating dye ethidium bromide which gives visible fluorescence on illumination of the gel with UV light; as little as 0.05 ug of DNA in one band can be detected by using this dye. This approach is useful when few DNA fragments with considered length differences are to be separated and studied. This approach also separates the closed circular (supercoiled), nicked (relaxed) and linear configuration of a single DNA molecule.

In many situations, it is critical to detect and identify DNA fragments in a sample that are complementary to a given DNA sequences, *e.g.*, to demonstrate the presence of the gene in question in transgenic, to detect and study RFLP (restriction fragment length polymorphism), etc. this is achieved by southern hybridization in which the following steps are performed.

1. The restriction fragments of DNA present in agarose gel (after electrophoresis) are denatured into single-stranded form by alkali treatment.
2. They are then transferred onto a nitrocellulose filter membrane; this is done by placing the gel on the top of a buffer saturated filter paper, then laying the nitrocellulose filter membrane on the gel, and finally placing some dry filter papers on the top of this membrane. The buffer moves, due to capillary action, from the bottom filter paper through the gel carrying with it the denatured DNA present in the gel; the DNA becomes trapped in the nitrocellulose membrane as the buffer phases through it. This process is known as *blotting* and takes several hours to complete. The relative positions of the bands on the membrane remain the same as those in the gel and there is a minimal loss in their resolution (sharpness)
3. The nitrocellulose membrane is now removed from the blotting stack, and the DNA is permanently immobilized on the membrane by baking it at 80°C in *vacuo*.
4. Single stranded DNA has a high affinity for nitrocellulose filter membrane. Therefore, the baked membrane is treated with a solution containing 0.2% each of Ficoll (an artificial polymer of sucrose), polyvinylpyrrolidone and bovine serum albumin; this mixture is often supplemented with an irrelevant nucleic acid, *e.g.*, tRNA (*pretreatment*). This treatment prevents nonspecific binding of the radioactive probe to be used in the next step) probably by attaching macromolecules to all the free binding sites on the membrane. Often the above mixture is included in the hybridization reaction itself.
5. The pretreated membrane is placed in a solution of radioactive, single stranded DNA or an oligodeoxynucleotide (a DNA segment having few to several nucleotides) called ***probe***. The name probe signifies the fact that this DNA molecule is used to detect and identify the DNA fragment in the gel/membrane that is complementary to the probe. The conditions

during this step are chosen so that the probe hybridizes with the complementary DNA on the membrane to the greatest extent with a low nonspecific binding on the membrane; this step is known as **hybridization reaction**. Usually, the initial hybridization reaction is carried out under conditions of relatively low stringency of hybridization to permit a high rate of hybridization; this is followed by a series of post-hybridization washes of increasing stringency, *i.e.*, higher temperature or, more commonly, lower ionic strength, with a view to eliminate the pairing of radioactive probe to related sequences and to allow only perfectly complementary pairing.

6. After the hybridization reaction, the membrane is washed to remove the unbound probes.
7. The membrane is now placed in close contact with an X-ray film and incubated for a desired period to allow images due to the radioactive probes to be formed on the film. The film is then developed to reveal distinct band(s) indicating positions in the gel of the DNA fragments that are complementary to the radioactive probe used in the study.

It should be kept in mind that electrophoresis of sheared or restricted DNA produces a smear in which the fragments are distributed in a continuum according to their size, and there are no distinct bands. The distinct bands are produced by the hybridization reaction of the selected probe with one or few fragment sequences present in the gel. The southern blotting technique is copy gene sequence in any genome (even of man). It is used for DNA fingerprinting, preparation of RFLP maps, detection and identification of the transferred genes in transgenic individuals etc.

Recently some new membrane materials, *i.e.*, nylon membranes, have been developed which have the following advantageous features: (1) they are physically robust in comparison to nitrocellulose filter membranes, (2) both DNA and RNA become cross-linked to them by a brief exposure to UV light, which (3) saves the time needed for baking in *vacuo* in the case of nitrocellulose membranes, and (4) the same membrane blot *e.g.*, a membrane onto which DNA/RNA has been transferred from a gel and cross-linked by UV exposure, can be used for search with more than one probe after removing the earlier probe by high temperature washing or some other denaturing procedure; in other words, the nylon membranes are reusable.



## **Application of Southern Blotting**

- Southern blotting technique is widely used to find specific nucleic acid sequence present in different animals including man. For example if we want to know whether there is a gene like insulin in sea anemone, then DNA of sea anemone is mobilized on membrane and blotted by using insulin probes against it.
- By using blotting technique we can identify infectious agents present in the sample.
- We can identify inherited disease.

---

## **15.4 Fluorescent In Situ Hybridization (FISH)**

---

The optical mapping method described above provides a link to the second type of physical mapping procedure that we will consider – FISH. As in optical mapping, FISH enables the position of a marker on a chromosome or extended DNA molecule to be directly visualized. In optical mapping the marker is a restriction site and it is visualized as a gap in an extended DNA fiber. In FISH, the marker is a DNA sequence that is visualized by hybridization with a fluorescent probe.

### **In situ hybridization with radioactive or fluorescent probes**

In situ hybridization is a version of hybridization analysis in which an intact chromosome is examined by probing it with a labeled DNA molecule. The position on the chromosome at which hybridization occurs provides information about the map location of the DNA sequence used as the probe. For the method to work, the DNA in the chromosome must be made single stranded ('denatured') by breaking the base pairs that hold the double helix together. Only then will the chromosomal DNA be able to hybridize with the probe. The standard method for denaturing chromosomal DNA without destroying the morphology of the chromosome is to dry the preparation onto a glass microscope slide and then treat with formamide.

In the early versions of in situ hybridization the probe was radioactively labeled but this procedure was unsatisfactory because it is difficult to achieve both sensitivity and resolution with a radioactive label, two critical requirements for successful in situ hybridization. Sensitivity requires that the radioactive label has a high emission energy (an example of such a radiolabel is  $^{32}\text{P}$ ), but if the radiolabel has a high emission energy then it scatters its signal and so gives poor resolution. High resolution is possible if a radiolabel with low emission

energy, such as  $^3\text{H}$ , is used, but these have such low sensitivity that lengthy exposures are needed, leading to a high background and difficulties in discerning the genuine signal.

These problems were solved in the late 1980s by the development of non-radioactive fluorescent DNA labels. These labels combine high sensitivity with high resolution and are ideal for in situ hybridization. Fluorolabels with different colored emissions have been designed, making it possible to hybridize a number of different probes to a single chromosome and distinguish their individual hybridization signals, thus enabling the relative positions of the probe sequences to be mapped. To maximize sensitivity, the probes must be labeled as heavily as possible, which in the past has meant that they must be quite lengthy DNA molecules - usually cloned DNA fragments of at least 40 kb. This requirement is less important now that techniques for achieving heavy labeling with shorter molecules have been developed. As far as the construction of a physical map is concerned, a cloned DNA fragment can be looked upon as simply another type of marker, although in practice the use of clones as markers adds a second dimension because the cloned DNA is the material from which the DNA sequence is determined. Mapping the positions of clones therefore provides a direct link between a genome map and its DNA sequence.

If the probe is a long fragment of DNA then one potential problem, at least with higher eukaryotes, is that it is likely to contain examples of repetitive DNA sequences and so may hybridize to many chromosomal positions, not just the specific point to which it is perfectly matched. To reduce this non-specific hybridization, the probe, before use, is mixed with unlabeled DNA from the organism being studied. This DNA can simply be total nuclear DNA (i.e. representing the entire genome) but it is better if a fraction enriched for repeat sequences is used. The idea is that the unlabeled DNA hybridizes to the repetitive DNA sequences in the probe, blocking these so that the subsequent in situ hybridization is driven wholly by the unique sequences. Non-specific hybridization is therefore reduced or eliminated entirely.

### **FISH in action**

FISH was originally used with metaphase chromosomes. These chromosomes, prepared from nuclei that are undergoing division, are highly condensed and each chromosome in a set takes up a recognizable appearance, characterized by the position of its centromere and the banding pattern that emerges after the chromosome preparation is stained. With metaphase chromosomes, a

fluorescent signal obtained by FISH is mapped by measuring its position relative to the end of the short arm of the chromosome (**the FLpter value**). A disadvantage is that the highly condensed nature of metaphase chromosomes means that only low-resolution mapping is possible, two markers having to be at least 1 Mb apart to be resolved as separate hybridization signals. This degree of resolution is insufficient for the construction of useful chromosome maps, and the main application of metaphase FISH has been in determining the chromosome on which a new marker is located, and providing a rough idea of its map position, as a preliminary to finer scale mapping by other methods.

For several years these 'other methods' did not involve any form of FISH, but since 1995 a range of higher resolution FISH techniques has been developed. With these techniques, higher resolution is achieved by changing the nature of the chromosomal preparation being studied. If metaphase chromosomes are too condensed for fine-scale mapping then we must use chromosomes that are more extended. There are two ways of doing this:

- Mechanically stretched chromosomes can be obtained by modifying the preparative method used to isolate chromosomes from metaphase nuclei. The inclusion of a centrifugation step generates shear forces which can result in the chromosomes becoming stretched to up to 20 times their normal length. Individual chromosomes are still recognizable and FISH signals can be mapped in the same way as with normal metaphase chromosomes. The resolution is significantly improved and markers that are 200–300 kb apart can be distinguished.
- Non-metaphase chromosomes can be used because it is only during metaphase that chromosomes are highly condensed: at other stages of the cell cycle the chromosomes are naturally unpacked. Attempts have been made to use prophase nuclei because in these the chromosomes are still sufficiently condensed for individual ones to be identified. In practice, however, these preparations provide no advantage over mechanically stretched chromosomes. Interphase chromosomes are more useful because this stage of the cell cycle (between nuclear divisions) is when the chromosomes are most unpacked. Resolution down to 25 kb is possible, but chromosome morphology is lost so there are no external reference points against which to map the position of the probe. This technique is therefore used after preliminary map information has been obtained, usually as a means of determining the order of a series of markers in a small region of a chromosome.

Interphase chromosomes contain the most unpacked of all cellular DNA molecules. To improve the resolution of FISH to better than 25 kb it is therefore necessary to abandon intact chromosomes and instead use purified DNA. This approach, called fiber-FISH, makes use of DNA prepared by gel stretching or molecular combing and can distinguish markers that are less than 10 kb apart.

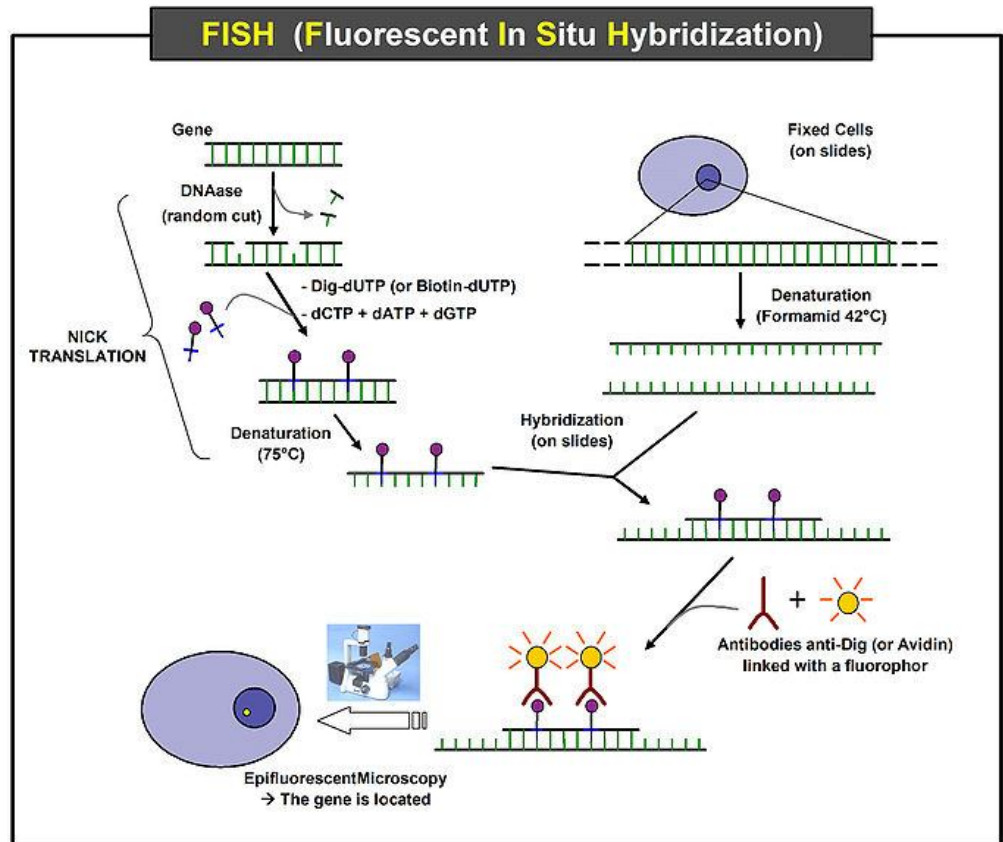

**Figure 2** *Fluorescent In Situ Hybridization*

## 15.5 Molecular Markers

The variations in the length of DNA fragments generated while cutting DNAs of related individuals with a restriction enzymes are used to identify the location of a gene on a chromosome. DNA fragment that give some information about gene of interest is known as molecular marker or genetic marker. They are very important to evaluate phenotypic differences in between the individuals of a species, to construct chromosomal maps and also to specify species. The molecular marker can be detected by gene cloning and PCR technique. They are useful in chromosomal walking and also to construct physical map of a chromosome.

**Conventional linkage maps** are based on only those genes, which produce distinct morphological effects. The limitations of such maps are (i) the number of such genes is rather limited even in the best studied species; (ii) their mapping is tedious and time taking, and (iii) genes governing quantitative traits (= quantitative trait loci) cannot be mapped. Therefore, attempts have been focused on using molecular markers, *i.e.*, differences among strains at the molecular level, *e.g.*, protein and DNA, for linkage mapping. There are several different types of molecular markers, *e.g.*, (i) isozymes, (ii) restriction fragment length polymorphism (RFLP), (iii) random amplified polymorphic DNAs (RAPDs), (iv) minisatellites and (v) microsatellites or short tandem repeat (STR) DNA.

**Isozymes** are variant forms of an enzyme usually detectable through electrophoresis due to differences in their net electrical charges. These were the first to be used leading to the development of many of the principles applicable to molecular markers. However, the limited number of goods isozymes loci in host species has shifted the focus to RFLPs and RAPDs, although interest in isozymes still continues.

The ideal molecular approach for population genomics should uncover hundreds of polymorphic markers that cover the entire genome in a single, simple and reliable experiment.

Genetic markers are variants in the DNA code (known as alleles) that, alone or in combination, are associated with a specific disease phenotype.

### **Markers for Genetic Mapping**

- **Phenotypic (morphological) markers:** based on polymorphism in physical appearance, *e.g.* flower color, leaf shape, seed coat, etc.
- **Cytological markers:** based on the structure and number of chromosomes, *e.g.* deletion, duplication, inversion, translocation, etc.
- **Biochemical markers:** Macromolecules: technically difficult Isozymes (allozymes=isozymes encoded by different alleles of the same gene): easily visualized by activity gels, etc.
- **Molecular markers:**
  - Based on DNA-DNA hybridization, *e.g.* RFLP, VNTR (if PCR is not possible)
  - Based on PCR
    - Using random primers: RAPD, DAF, AP-PCR, ISSR

- Using specific primers: SSR, SCAR, STS
- Based on PCR and restriction cutting: AFLP, CAPS
- Based on DNA point mutations (SNP), can be detected by SSCP, DASH, DNA chip, sequencing, etc

### **15.5.1 Restriction Fragment Length Polymorphism (RFLP)**

The variation in the restriction DNA fragment lengths between individuals of a species is called RFLP. This is the best laboratory technique to analyze and compare DNA of two or more individuals of a species or different species. Basically it is used in genome analysis.

*Restriction fragment length polymorphism* denotes that a single restriction enzyme produces fragments of different lengths from the same stretch of genomic DNA of different strains of species or from different related species. RFLPs are detected as follows; (i) large molecular weight genomic DNA is isolated from several strains or related species, (ii) these DNAs are then digested with selected restriction enzymes, (iii) the fragments in these digests are separated through electrophoresis; (iv) the resulting gel lanes are transferred to a suitable solid support and exposed to a suitably radio-labelled appropriate DNA probe under conditions favoring DNA: DNA hybridization (southern hybridization), (v) the free probes (not involved in hybridization) are removed, and finally (vi) the fragments to which the probe had hybridized are detected by filming them as distinct bands on a suitable photofilm through radioautography.

The pattern of RFLPs generated will depend mainly on the following: (i) differences in the DNAs of selected strains/ species, (ii) the restriction enzymes used and (iii) the DNA probe employed for southern hybridization. Detectable RFLPs are generated due to the following changes in the DNAs of organisms: (i) changes in the base sequences of recognition sites of the restriction enzymes used, (ii) relatively large deletions and (iii) relatively large additions in the concerned stretch of genomic DNA. A very large number of restriction enzymes is now available permitting the selection of such enzymes that would generate RFLPs.

The DNA probes may be obtained from (i) genomic libraries, (ii) cDNA libraries (these may be random or specific), or (iii) chromosome specific libraries obtained from addition/ substitution lines, flow sorted chromosomes, chromosome specific repeated sequences or micro dissected chromosomes, single copy sequences (representing most likely, structural genes) are the best probes, but low copy and even multiple copy sequences are also used.

Generally, probes prepared from the same species are used, but those from other species may also be employed.

RFLP is detected as a differential movement of a band on the gel lanes from different species/ strains: each band is regarded as a single RFLP locus. It may be noted that RFLP locus is definable only by the combination of a specific restriction enzymes with a specific DNA probe. The linkage among different RFLP loci and that between RFLP loci and oligogenes/ polygenes is readily determined by studying (i) a set of recombinant inbreds derived from a suitable cross, or (ii)  $F_2$  or backcross progeny from such a cross. (A *suitable cross* means the cross between two strains differing for the concerned RFLP loci and/or oligogenes/polygenes.) RFLP maps similar to the conventional linkage maps can be readily prepared, and these can be effectively integrated with the genetic maps prepared conventionally. Efficient protocols for such mapping have been developed. The RFLP maps can be assigned to specific chromosomes. Chromosome arms based on: (i) linkage with genetic markers already assigned to specific chromosomes, (ii) use of addition/ substitution lines, (iii) study of suitable translocation stocks, (iv) employing monosomic / trisomic lines, or (v) *in situ* hybridization to polytene chromosomes.

RFLPs have several unique advantages: (i) the number of RFLP loci is very large so that even very small segments of the chromosomes can be used mapped; *ideally* every cistron could be mapped; (ii) mapping does not necessarily depends on the gene function, (iii) even quantitative trait loci can be mapped which is virtually impossible through conventional techniques, (iv) it is astoundingly rapid as compared to conventional linkage mapping and (v) fewer individuals (25-50 individuals/  $F_2$  generation) need to be studied.

However, (i) the technique is 100 to 1000 times as costly as the conventional linkage mapping. (ii) it utilizes radioactive probes which are risky to handle and difficult to dispose off. Further, (iii) the technique requires considerable skill and effort, and far greater time than, say, RAPDs (random amplified polymorphic DNAs)

RFLPs may have the following applications: (i) identification and isolation of any gene known to be linked with an RFLP locus, (ii) *finger- printing* of strains / varieties for their unequivocal identification, (iii) linkage mapping of quantitative trait loci, (iv) identification of the most important loci affecting a quantitative trait, (v) highly efficient indirect selection for tightly linked quantitative trait loci and even for those oligogenes a direct selection for which may either be difficult or costly, (vi) determination of chromosomes segments

alteration of which is likely to yield the best results, (vii) establishing the relationships among various strains/ species, (viii) understanding the identity and function of thus far ‘mysterious’ polygenes etc. RFLP maps are being generated for several crop species, e.g., more notably, maize rice, wheat, etc.; it is hoped that entire genome of *Arabidopsis thaliana* will soon be mapped to saturation or even sequenced in full.

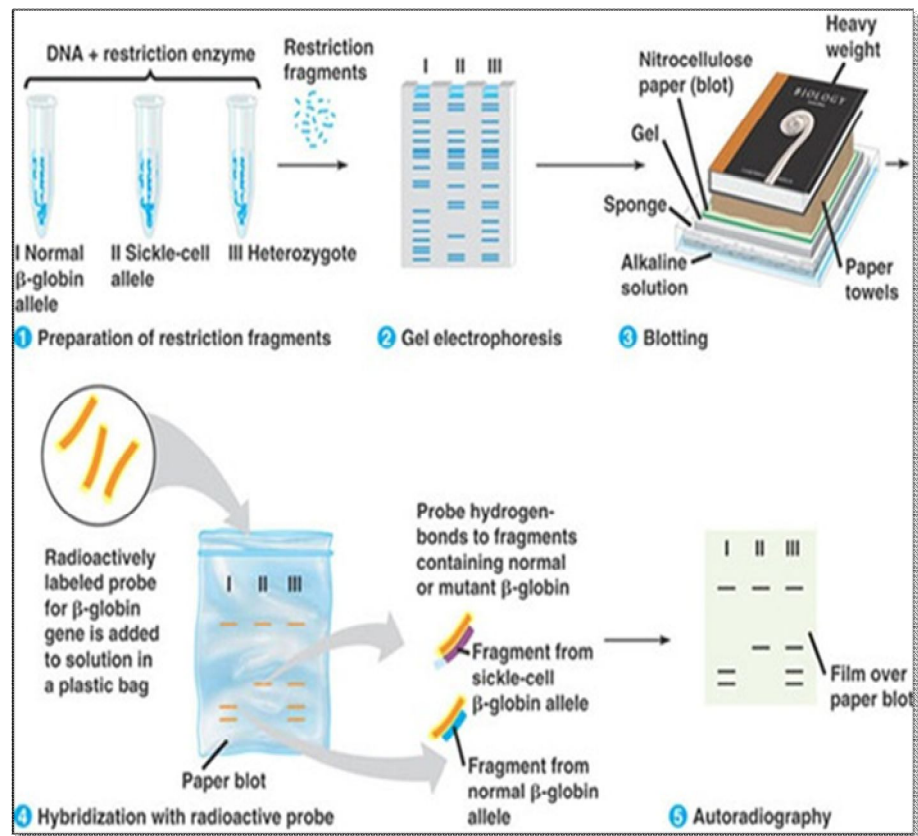

**Figure 3 Restriction Fragment Length Polymorphism**

#### Applications of RFLP:

- 1) Paternity case:** RFLP can be used in paternity cases or criminal cases to determine the source of DNA sample. (i.e it has forensic applications)
- 2) Detection of Recombination Rate:** RFLPs can be used to measure recombination rates which can lead to a genetic map with the distance between RFLP loci.
- 3) Agriculture:** Direct method for detecting desirable genes such as disease resistance.
- 4) Genetic Mapping:** Determine disease status of an individual i.e Huntington’s chorea.



5) **Genetic Counseling:** Very important when discussing results with patients or parents who use this technology to have children who are free of genetic diseases.

6) **Disease Detection:** RFLP can be used to determine the disease status of an individual (eg. It can be used in the detection of particular mutations).

### 15.5.2 Random Amplified Polymorphic DNAs (RAPDs)

RAPDs (random amplified polymorphic DNAs) are a PCR based method to detect variation between individuals of a species by selective amplification of some polymorphic sequence in their genome. This method was developed by Williams's et.al. in 1981. Plants and animal genomes have several sets of polymorphic sequences. A set of polymorphic sequences shows a unique structure with differences in one or few bases. A common primer made for a set can bind with all DNA fragments containing the polymorphic sequences. When the genomic DNA is treated with a primer in PCR, the primer anneals randomly with the set of polymorphic sequences and then polymerization continues from the pieces of primer attached to different sites of the genomic DNA. The set of DNAs generated by the random PCR is called random amplified polymorphic DNA. It is different from one individual to another individual both in number and size of the DNA fragments. This feature is used to identify different individuals of a species.

The procedure, in simple terms, for obtaining RAPDs is as follows.

1. The genomic DNA of a selected strain/ variety/ species is isolated in a high molecular weight condition.
2. To this DNA is added an excess of a selected oligonucleotide ( a short polynucleotide; usually, 10 bases long) that serves as the primer. The oligonucleotide is usually obtained by *in vitro* DNA synthesis, for which often sophisticated equipment (called gene machine or oligonucleotide synthesizer) is used.
3. This mixture is subjected to repeated cycles of DNA Denaturation- renaturation- DNA replication in PCR equipment. During renaturation, following denaturation, the oligonucleotide will pair with the homologous sequence present at different locations in the genomic DNA; therefore, DNA replication will extend the oligonucleotide and copy the sequence continuous with the sequences with which selected oligonucleotide had paired. The repeated cycles of denaturation –renaturation –DNA replication will, therefore, amplify this sequence of the genomic DNA.

Amplification will take place only of those regions of the genome that have the sequence complementary to the random primer at both their ends.

4. After several cycles of amplification, the DNA is subjected to gel electrophoresis. The amplified DNA will form a distinct band, which is usually detected by ethidium bromide staining and visible fluorescence under UV light.

It may be pointed out that RAPD approach does not utilize restriction enzymes (which are very costly) and probes of any kind; therefore, they save both cost and effort in comparison to RFLPs. They have the same use as RFLPs but often show poor reproducibility. The RAPD technique is based on PCR. The oligonucleotide used may represent the base sequence of a short segment of the genomic DNA that is already known; variation in the sequence of this segment can now be detected by the RAPD approach. However, when this information is either unavailable or is not desirable for use, oligonucleotide having random base sequence can be used.

Those strains that have a segment of DNA both the ends of which are homologous to the oligonucleotide used, a distinct band will be seen on the agarose gel. However, this band will be absent in the strains in which one or both the ends of this sequence of genomic DNA is either modified or deleted. Thus RAPD bands are either 'present' or 'absent' in different strains. Further, the F1 from the cross 'present' or 'absent' strains for an RAPD band will always show the band; thus RAPD bands have dominant expression, while RFLP bands, in contrast, show co dominant expression, *i.e.*, the *F1*'s show the bands of both the parents.

#### **Limitations of RAPD**

1. Nearly all RAPD markers are dominant, *i.e.* it is not possible to distinguish whether a DNA segment is amplified from a locus that is heterozygous (1 copy) or homozygous (2 copies). Codominant RAPD markers, observed as different-sized DNA segments amplified from the same locus, are detected only rarely.
2. PCR is an enzymatic reaction, therefore the quality and concentration of template DNA, concentrations of PCR components, and the PCR cycling conditions may greatly influence the outcome. Thus, the RAPD technique is

notoriously laboratory dependent and needs carefully developed laboratory protocols to be reproducible.

3. Mismatches between the primer and the template may result in the total absence of PCR product as well as in a merely decreased amount of the product. Thus, the RAPD results can be difficult to interpret.

#### **Applications of RAPD:**

It has become widely used in the study of genetic diversity/polymorphism, germplasm characterization, genetic structure of populations, domestication, detection of somaclonal variation, cultivar identification, hybrid purity, genome mapping, developing genetic markers linked to a trait in question, population and evolutionary genetics, plant and animal breeding, animal-plant-microbe interactions, pesticide/herbicide resistance.

#### **15.5.3 AMPLIFIED FRAGMENT LENGTH POLYMORPHISM**

The AFLP is a method to detect polymorphism in the DNA throughout the genome. It is similar to RFLP in the identification of DNA fragments produced by restriction digestion, but differ from RFLP in PCR based amplification. It detects the presence or absence of a fragment but not the length of fragment. This method was Vos *et.al.*, 1995.

Amplified Fragment Length Polymorphism uses restriction enzymes to digest genomic DNA, followed by ligation of adaptors to the sticky ends of the restriction fragments. A subset of the restriction fragments is then selected to be amplified. This selection is achieved by using primers complementary to the adaptor sequence, the restriction site sequence and a few nucleotides inside the restriction site fragments. The amplified fragments are separated and visualized on denaturing polyacrylamide gels, either through autoradiography or fluorescence methodologies, or via automated capillary sequencing instruments. AFLP-PCR used in genetics research, DNA fingerprinting, and in the practice of genetic engineering.

AFLP-PCR is a highly sensitive method for detecting polymorphisms in DNA and this technique is divided into three steps:

- 1) Digestion of total cellular DNA with one or more restriction enzymes and ligation of restriction half-site specific adaptors to all restriction fragments.
- 2) Selective amplification of some of these fragments with two PCR primers that have corresponding adaptor and restriction site specific sequences.
- 3) Electrophoretic separation of amplicons on a gel matrix, followed by visualisation of the band pattern.

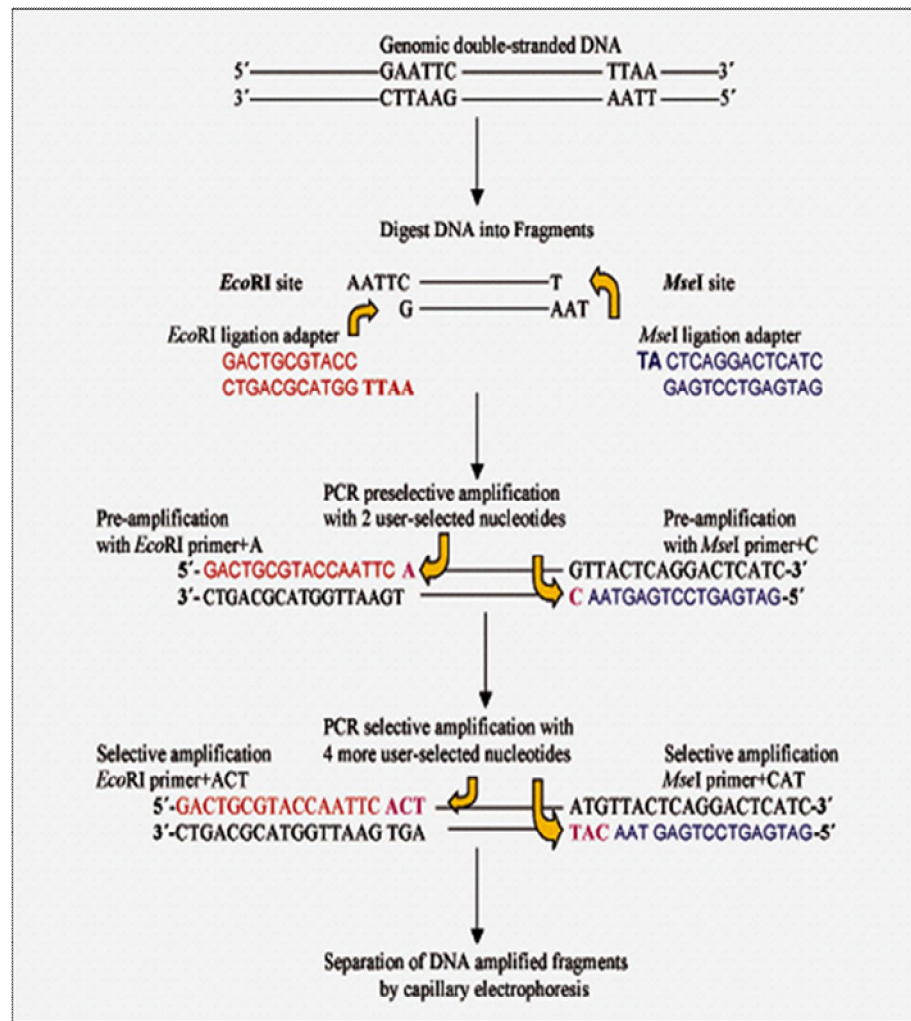

**Figure 4 Amplified Fragment Length Polymorphism**

### Applications of AFLP:

The AFLP technology has the capability to detect various polymorphisms in different genomic regions simultaneously. It is also highly sensitive and reproducible. As a result, AFLP has become widely used for the identification of genetic variation in strains or closely related species of plants, fungi, animals, and bacteria. The AFLP technology has been used in criminal and paternity tests, also to determine slight differences within populations, and in linkage studies to generate maps for quantitative trait locus (QTL) analysis. There are many advantages to AFLP when compared to other marker technologies including randomly amplified polymorphic DNA (RAPD), restriction fragment length polymorphism (RFLP), and microsatellites. AFLP not only has higher reproducibility, resolution, and sensitivity at the whole

genome level compared to other techniques, but it also has the capability to amplify between 50 and 100 fragments at one time. In addition, no prior sequence information is needed for amplification. As a result, AFLP has become extremely beneficial in the study of taxa including bacteria, fungi, and plants, where much is still unknown about the genomic makeup of various organisms.

---

## 15.6 Summary

---

Eukaryotic genomes are complex, consisting of not only unique functional genes present once in the genome, but also families of tandem and dispersed function genes, as well as several types of non coding and apparently nonfunctional repetitive sequences. Genomic analysis is important for two reasons: first, it affords a way of obtaining an overview of the genetic architecture of an organism, and, second, it forms a set of basic information that can be used to find new genes such as those involved in human disease. Initially, genes must be assigned to chromosomes, and this assignment can be achieved by a variety of techniques including linkage to standard markers, in situ hybridization, pulsed field gel electrophoresis, and human–rodent cell hybridization. Particularly useful are molecular markers that can fill in the gaps between genes of known phenotypic association. RFLPs, RAPDs and AFLPs all provide heterozygous loci that can be used as molecular marker loci in mapping. The highest level of genomic resolution is the physical mapping of DNA fragments. From your study of this chapter, you should be better placed to understand, and hopefully contribute to, the debate over the use and control of genetic modification through molecular markers and genomic mapping.

---

## 15.7 Glossary

---

- **Ancient DNA:** Preserved DNA from an archaeological or fossil specimen.
- **Bacteria:** One of the two main groups of prokaryotes.
- **Biotechnology** The use of biological processes in industry and technology.
- **cDNA:** A double-stranded DNA copy of an mRNA molecule.
- **Clone:** A group of cells that contain the same recombinant DNA molecule.

- **Comparative genomics** A research strategy that uses information obtained from the study of one genome to make inferences about the map positions and functions of genes in a second genome.
- **Conjugation:** Transfer of DNA between two bacteria that come into physical contact with one another.
- **Conjugation mapping:** A technique for mapping bacterial genes by determining the time it takes for each gene to be transferred during conjugation.
- **Denaturation:** Breakdown by chemical or physical means of the non-covalent interactions, such as hydrogen bonding, that maintain the secondary and higher levels of structure of proteins and nucleic acids.
- **DNA:** Deoxyribonucleic acid, one of the two forms of nucleic acid in living cells; the genetic material for all cellular life forms and many viruses.
- **DNA marker:** A DNA sequence that exists as two or more alleles and which can therefore be used in genetic mapping.
- **DNA polymerase:** An enzyme that synthesizes DNA on a DNA or RNA template.
- **DNA profiling** A PCR technique that determines the alleles present at different STR loci
- with in a genome in order to use DNA information to identify individuals.
- **DNA sequencing:** Determination of the order of nucleotides in a DNA molecule.
- **Endonuclease:** An enzyme that breaks phosphodiester bonds within a nucleic acid molecule.
- **Expressed sequence tag (EST):** A partial or complete cDNA sequence.
- **Functional genomics** Studies aimed at identifying all the genes in a genome and determining their expression patterns and functions.
- **Gene:** A segment of DNA that codes for an RNA and/or polypeptide molecule.

- **Genetic map:** A genome map that has been obtained by analyzing the results of genetic crosses.
- **Genetics:** The branch of biology devoted to the study of genes.
- **Genome:** The entire genetic complement of a living organism.
- **Gene mapping:** Determination of the relative positions of different genes on a DNA molecule.
- **Hybridization:** The formation of double-stranded nucleic acid molecules by the production
  - of hydrogen bonds between wholly or partially complementary sequences.
- ***In situ* hybridization:** A technique for gene mapping involving hybridization of a labeled sample of a cloned gene to a large DNA molecule, usually a chromosome.
- **Ligation:** Joining two DNA molecules using DNA ligase.
- **Map:** A chart showing the positions of genetic and/or physical markers in a genome
- **Mapping:** Determination of the position of genes (genetic map), or of physical features such as restriction endonuclease sites (physical map).
- **Microsatellite** A polymorphism comprising tandem copies of, usually, two-, three-, four- or five-nucleotide repeat units. Also called a short tandem repeat (STR).
- **Physical map:** A map of the physical structure of a genome, e.g. showing restriction sites, position of specific clones, or ultimately the complete sequence (c.f. genetic map).
- **Primer:** A specific oligonucleotide, complementary to a defined region of the template
  - strand, from which new DNA synthesis will occur.
- **Probe:** A nucleic acid molecule that will hybridize to a specific target sequence.

- **Restriction:** Reduction or prevention of phage infection through the production of restriction endonucleases which degrade foreign DNA(see also modification).
- **Restriction endonuclease:** An enzyme that recognizes specific DNA sequences and cuts the DNA, usually at the recognition site.
- **Restriction fragment length polymorphism (RFLP):** Variation between individuals or strains in the size of specific restriction fragments; used for strain typing, and for locating particular genes.
- **Restriction mapping:** Determination of the position of restriction endonuclease recognition sites on a DNA molecule.
- **RFLP linkage analysis:** A technique that uses a closely linked RFLP as a marker for the presence of a particular allele in a DNA sample, often as a means of screening individuals for a defective gene responsible for a genetic disease.
- **Selectable marker:** A gene carried by a vector and conferring a recognizable characteristic on a cell containing the vector or a recombinant DNA molecule derived from the vector.
- **Sequence tagged site (STS):** A DNA sequence whose position has been mapped in a genome.
- **Short tandem repeat (STR):** A polymorphism comprising tandem copies of, usually, two-, three-, four- or five-nucleotide repeat units. Also called a microsatellite.
- **Single nucleotide polymorphism (SNP):** A point mutation that is carried by some individuals of a population.

---

## 15.8 Self-Learning Exercise

---

### Section -A (Very Short Answer Type)

1. What are genetic markers? Name some of them?
2. Define somatic cell mapping?
3. Expand ESTs and SSLPs?
4. Difference between clones and clonecontig?



5. One map unit = \_\_\_\_\_ = \_\_\_\_\_ between loci.
6. Enzyme usually detectable through electrophoresis due to differences in their net electrical charges is known as \_\_\_\_\_.
7. If two loci are linked, the alleles that are described as \_\_\_\_\_, alleles on opposite homologous chromosomes are in \_\_\_\_\_.
8. Name some biochemical and molecular markers.
9. Expand RAPD, RFLP and AFLP.

#### **Section -B (Short Answer Type)**

1. Explain why a map is an important aid to genome sequencing.
2. Distinguish between the terms 'genetic map' and 'physical map'.
3. Write a short note on Southern Hybridization.
4. Mention some applications and limitations of RAPD.
5. Difference between RFLP and AFLP.

#### **Section -C (Long Answer Type)**

1. What is RFLP? Discuss it with its application.
2. Write an explanatory note on FISH.
3. Discuss the importance of molecular mapping. Elaborate its types.
4. Give an account detailed on Molecular marker.

---

## **15.9 References**

---

- Brown, T. A. (2001). *Gene cloning an introduction, 4th edition*. Blackwell Science, Oxford, UK
- Purohit. S.S. (2005). *Biotechnology: Fundamentals and Applications*. Agrobios, India
- Singh. B.D. (2010). *Biotechnology*. Kalyani Publishers. India
- Watson, J. D.(1992). *Recombinant DNA, 2nd edition*. Scientific American Books,
- USA.
- Primrose, S. B., Twyman, R., Old, R. W. (2001). *Principles of gene manipulation, 6th*

- *edition*. Blackwell Science, Oxford, UK.
- Kumaresan, V 2013. Biotechnology Sixth edition, *Saras publication, India*

# Unit 16

---

## Gene Regulation

---

### Structure of the Unit

- 16.0 Objective
- 16.1 Introduction
- 16.2 Positive and Negative Regulation
- 16.3 Gene regulation in prokaryotes
  - 16.3.1 *lac* Operon
  - 16.3.2 *trp* Operon
- 16.3 Gene regulation In Eukaryotes
- 16.4 Summary
- 16.5 Exercise
- 16.6 Glossary
- 16.7 Further readings

---

### 16.0 Objective

---

After reading this unit you will come to know about various modes of gene regulation in prokaryote and eukaryotes. In this unit we will read about level of gene regulation and mechanisms involved in these levels in different groups of organisms. You will come to know about positive and negative regulation and Operon concept as well. We will also discuss about gene regulatory proteins.

---

### 16.1 Introduction

---

Genome of a cell usually contains several thousand genes. Some of the gene products are required under general growth conditions and such genes are known as **housekeeping genes**. On the other hand products of some genes are required only at specific conditions e.g. Specific enzymes and hormones.

Housekeeping genes are generally expressed all the time while specific gene products are not required all the time. On and off mechanism for such genes is known as gene regulation.

Gene regulation can occur at three levels i.e. **transcriptional, translational** and **post-transcriptional** or **post-translational**.

---

## 16.2 Principles of Gene Regulation

---

Expression of housekeeping genes is known as **constitutive gene expression**. For other gene products, cellular level rise and fall in response to molecular signals, this is known as **regulated gene expression**. Gene products that increase in concentration under particular molecular circumstances are referred as **inducible** and the process of increasing their expression is **induction**. On the other hand gene products that decrease in concentration in response to a molecular signal are referred to as **repressible** and the process is called **repression**.

Transcription is mediated and regulated by protein-DNA interactions, especially those involving the protein component of RNA polymerase. Various Proteins alter the specificity of RNA polymerase for a given promoter or a set of given promoters. **Repressors** impede access of RNA polymerase to the promoter and **Activators** enhance the RNA polymerase-promoter interaction. Regulation by mean of a repressor protein that blocks the transcription is known as **Negative regulation** while Activators provide a molecular counterpoint to repressors, they bind to DNA and enhance the activity of RNA (Fig. 16.1) polymerase at a promoter, and this is referred as **Positive Regulation**.

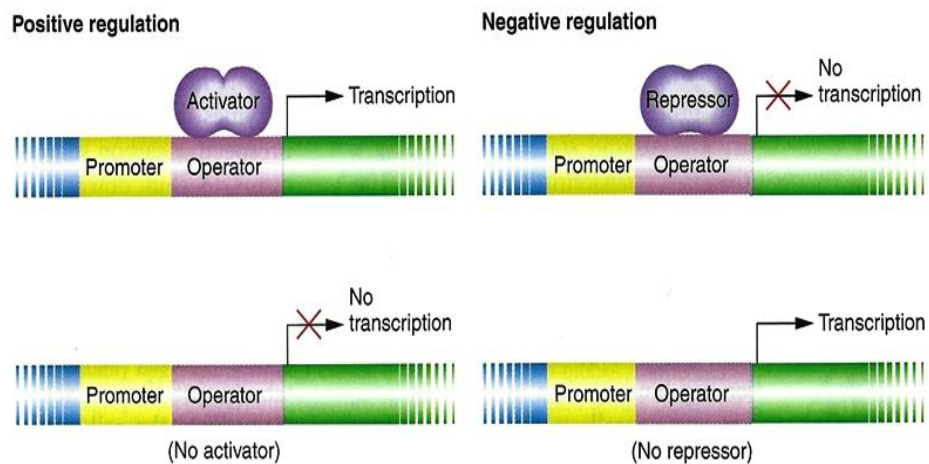

**Fig. 16.1- Positive and Negative regulation**

---

## 16.3 Gene regulation in prokaryotes

---

Most bacterial gene regulations occur at the transcriptional level because it would be a waste to make the RNA, if RNA and its encoded protein are not

needed. Regulation in prokaryotes was explained through Operon Model by Jacob and Monod.

### 16.3.1 *lac* Operon

In *E. coli* two proteins are necessary for the metabolism of lactose sugar.  **$\beta$ -galactosidase**, cleaves lactose to yield galactose and glucose and a carrier molecule, **galactoside permease**, which is required for the entry of lactose into the cell. If a culture of *E. coli* (Genotype-  $lac^+$ ) is growing in a medium lacking lactose, the intracellular concentration of  $\beta$ -galactosidase is almost negligible. On the other hand if lactose is present in the growth medium the concentration of these proteins is raised.

If lactose is added to a  $lac^+$  culture growing in a lactose free medium, both  $\beta$ -galactosidase and permease are synthesised simultaneously. These facts led to the view that the lactose (*lac*) system is **inducible** and the lactose is **inducer**.

Regulation of the *lac* system is explained by operon model, which has the following features. (Fig.- 16.2)

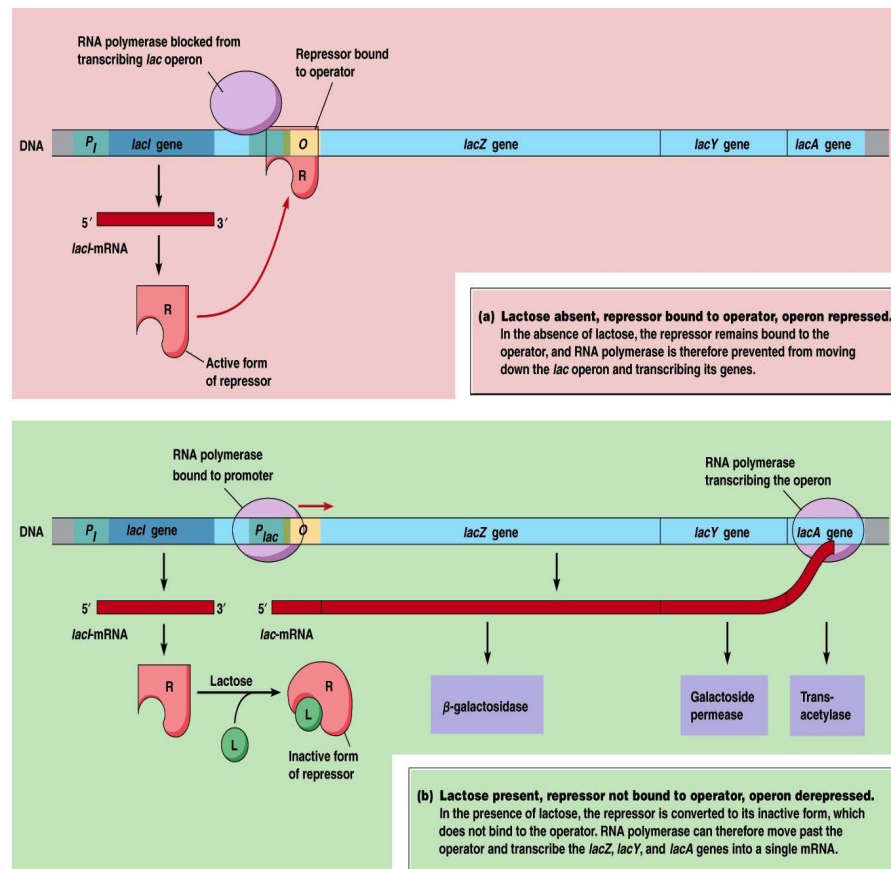

Fig. 16.2- *lac* operon

1. Products of the *z* and *y* genes are encoded in a single polycistronic mRNA molecule.
2. The promoter for this mRNA is immediately adjacent to the *o* region. Promotor mutations ( $p^-$ ) completely incapable of making both both  $\beta$ -galactosidase and permease have been isolated and located between *i* and *o*.
3. The operator is a sequence of bases to which the repressor protein binds.
4. When the repressor protein is bound to the operator, transcription of *lac* mRNA cannot be initiated.
5. Inducers stimulate mRNA synthesis by binding to the repressor. This binding alters the three-dimensional structure of the repressor so it cannot bind to the operator.

Thus in the presence of an inducer the operator is unoccupied and the promoter is available for initiation of mRNA synthesis. This is often called **derepression**. If lactose and glucose are added to a culture of wild type *E. Coli* cells, the *lac* operon is not induced. This effect of glucose is the result of a second regulatory mechanism known as **catabolic repression** because in this situation bacteria has the choice of glucose to metabolize in place of lactose hence there is no use of expression of *lac* operon.

### 16.3.2 *trp* Operon

Tryptophan (*trp*) operon is responsible for the synthesis of tryptophan. Regulation of this operon is based on the principle that when tryptophan is present in growth medium, there is no need to activate the *trp* operon. Thus there is a regulatory mechanism that turns *trp* transcription off when adequate tryptophan is present and turns it on when it tryptophan is absent. This operon is active in repression rather than the induction.

Tryptophan is synthesized in five steps, each requiring a particular enzyme. The genes encoding these enzymes are adjacent to one another in the sane order as their use in biosynthesis pathway. They are translated from a single polycistronic mRNA and are called *trpE*, *trpD*, *trpC*, *trpB* and *trpA*. The *trpE* gene is the first one translated. Adjacent to this gene are the promoter, the operator and two regions called **leader** and **attenuator**, which are designated as *trpL* and *trp a* (Not *trpA*). The repressor gene *trpR* is located very far from this gene cluster.(Fig. 16.3) The protein product of the *trpR* gene, which is often called as *trp aporepressor*, does not bind to the operator unless tryptophan is present. The aporepressor protein and tryptophan molecule join together to form an active repressor that binds to form an active repressor that binds to the operator.

Aporepressor alone  $\xrightarrow{\text{No repressor}}$  (Transcription occurs)

Aporepressor + Tryptophan  $\xrightarrow{\text{Active Repressor + Operator}}$

↓  
Inactive promoter

(Transcription does not occur)

Only when tryptophan is present, an active repressor molecule inhibits transcription. This repressor-operator mechanism is sufficient on-off switch for *trp* operon, however an additional mechanism allows a fine control in which the enzyme concentration is varied according to the amino acid concentration. These are (i) Premature termination of transcription before the first structural gene is reached (**Attenuation**) and (ii) regulation of the frequency of this termination by the concentration of amino acid.

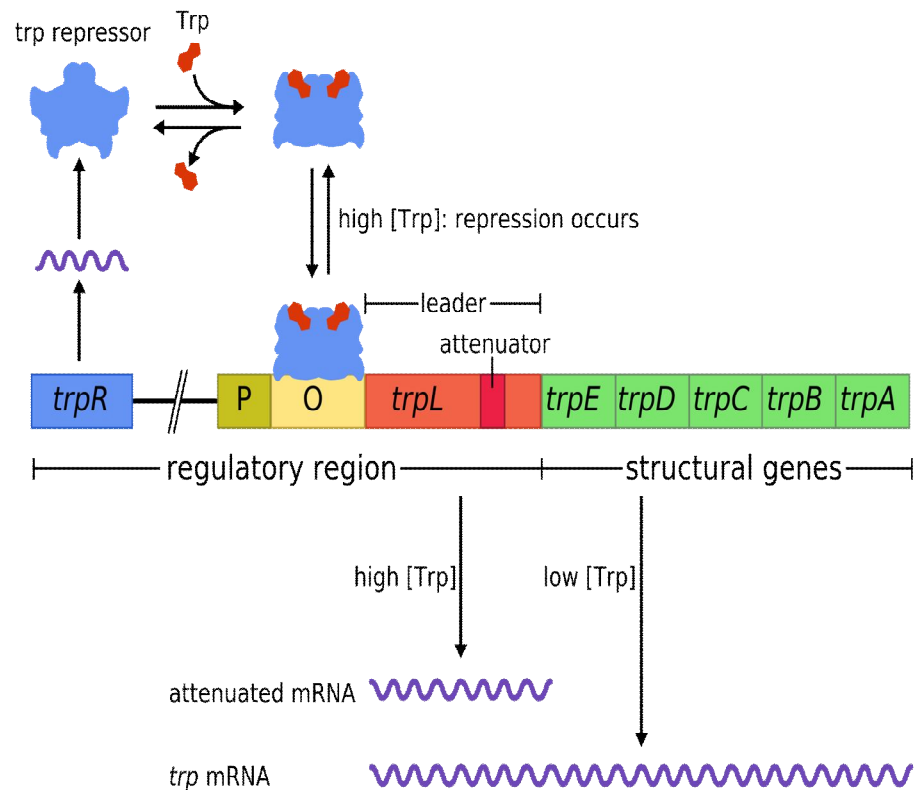

**Fig. 16.3- *trp* operon**

---

## 16.3 Gene regulation In Eukaryotes

---

Eukaryotic genome organization differs from prokaryotic genome in following ways-

- 1- In eukaryotes usually only a single type of polypeptide chain can be translated from a RNA molecule, thus operons of the type seen in prokaryotes are not found in eukaryotes.
- 2- The Eukaryotic DNA is bound to histone for forming chromatin and to numerous non histone proteins. Only a small fraction of DNA is free. In bacteria some proteins are present in the folded chromosome but most of the DNA is free.
- 3- A large fraction of the DNA sequence in eukaryotic DNA is remain un-translated
- 4- The bases of the gene and the amino acid of the gene product are usually not collinear in eukaryotes. Introns are present in most eukaryotic genes and RNA must be processed before translation begins.
- 5- In eukaryotes, RNA is synthesized in the nucleus and must be transported through the nuclear membrane to the cytoplasm where it is utilized, such extreme compartmentalization does not occur in bacteria.

Thus gene expression in eukaryotes may be regulate at following levels –

- 1- Genome
- 2- Replication
- 3- Transcription
- 4- Post transcription
- 5- Translation
- 6- Post translation

### Regulation At The Level Of Genome

- (a) **Z-DNA & its role in regulation-** Z-DNA is left handed and formed when the untwisting of DNA cause negative super coiling which would be left handed. Under such circumstances it might be expected that transcription would then be allowed to proceed more rapidly. Mutations in virus that prevent Z-DNA forming also inhibit multiplication of virus.
- (b) **DNA methylation-** Inactive DNA sequence is heavily methylated than that of transcribing sequence. In some cases gene activation has been shown to be associated with removal of methyl groups.



## Regulation At The Level Of Dna Replication

- (a) **Gene amplification** – Amplification denote the production of a greater number of copies of a genome. Amplification of a complete genome occurs in the Oocyte cells of the coracoids Planococcus. Planococcus males have 5 maternal chromosomes which are euchromatic and 5 paternal chromosomes that are heterochromatic. In Oocyte cells 5 maternal euchromatic chromosomes are selectively replicated several times so that a cell may contain up to 80 maternal chromosomes. (But only 5 paternal chromosomes.)
- (c) **Gene Destruction** – Gene destruction Occurs in some organism as a loss of a chromosome or a chromosome part. Whole chromosome is routinely lost from master. So it also participates in gene regulation.
- (d) **Gene distribution** – Gene distribution during meiosis is affected by meiotic drive in a few cases.

## Regulation At The Level Of Transcription –

### (a) **The promoter related control -**

In the process of transcription for Eukaryotes, there are conserved sequences at the promoter site ( TATA box centered at – 25 b.p.). Attachment of a specific protein factor at TATA Box assures correct attachment of RNA polymerase while attachment of a protein factor at GC box or CAAT box determines the frequency of transcription. Mutation in these regions reduces frequency of transcription by about 10 to 20 folds.

There are two types of promoter related control-

- (i) Positive Regulation
- (ii) Negative Regulation

The binding of regulation protein to the promoter is essential for initiation of transcription. It's called positive regulation. A good example of Negative regulation is presented by a gene of histone H<sub>2</sub>B in sea urchin. The promoter of this H<sub>2</sub>B gene has two CAAT Boxes to which two molecule of the CAAT binding factor attach ; this is essential to allow the transcription to be initiate. However in tissue other than testes, the embryonic tissue, the CAAT boxes are occupied by molecule of a CAAT displacement factor. As a result, the CAAT binding factor and the RNA polymerase are unable to bind to the H<sub>2</sub>B promoter and transcription of this gene is prevented.

#### **b. The Enhancer sequence-**

Many promoters have their activity modulated by an enhancer. The enhancer may be situated upstream, downstream or even within the gene which is being transcribed. Enhancer elements have been identified in gene regulated by steroid hormone. When the hormone receptor complex attaches at the enhancer site, the transcription process is greatly increased

**c. Transcriptional gene control by heterochromatinization and euchromatinization** Generally, prior to cell division, most chromatin is in condensed form. Between cell division, the bulk of the chromatin in most cells is well dispersed within the nucleus. It has long been felt that the more compact (super coiled) heterochromatin is probably transcriptional silent and that loosening of chromatin structure may permit transcription and perhaps even regulated. Following evidences support this idea-

- **Gene Expression and Barr body :-**

One of the two x chromosome in female mammals is known to fall into that category. Genes on this heterochromatic x chromosome are not expressed. Where the allele on the euchromatic x chromosome are expressed normally

- **Gene expression and lampbrush chromosome :-**

Another example where chromatin unfolding accompanies transcription is found in the lampbrush chromosome. It has demonstrated that transcription is taking place in the loops.

- **Gene expression and polytene chromosome:-**

One of the earliest correlations between unfolding and transcription was noted in insects. In polytene chromosome of insect larvae, the expression of gene activity is observed in the so called puffs and Balbiani rings. At the puffs there is uncoiling of the chromosome bands, followed by the synthesis of RNA (transcription) and accumulation of proteins.

#### **d. Role of histone & Non histone in gene regulation**

Non histone proteins found in a chromatin together with histone proteins, also participate in gene expression. This kind of knowledge about histone is long known but regulation by Non- histone proteins is recently known. There are several evidences in support.

1. In actively transcribing cells, non histone proteins are found in increased amount where as the quantity of histone proteins remain constant.

- Non histones show a much higher structural diversity as compared to histones. It is about two to three times higher.

Synthesis of specific non histone is associated with induction of gene activity.

### Gene Regulation Model at the transcriptional level (Gene Battery Model)

Britin and Devidson (1973) proposed gene battery model. This model proposed that the eukaryotic genome contain a large number of sensor sites which recognize various signalling agents. The Signalling agents may induce hormone receptor complexes or substrates of specific enzyme,

An Important feature of Briton and Devidson model is that the structural genes make up a small part of the large genome and much of the DNA function in regulation in the form of sensor, integrator & receptor loci.

The model consists of four classes of sequences.

- Producer Gene – It is similar to structural gene of prokaryotes.
- Receptor site – It is comparabile to operator gene of prokaryotes
- Integrator gene – It is comparable to regulator gene which synthesis activator RNA and activates receptor site.
- Sensor Site – It regulates activity of integrator gene which can be transcribed only when sensor site is activated. (Fig. 16.4)

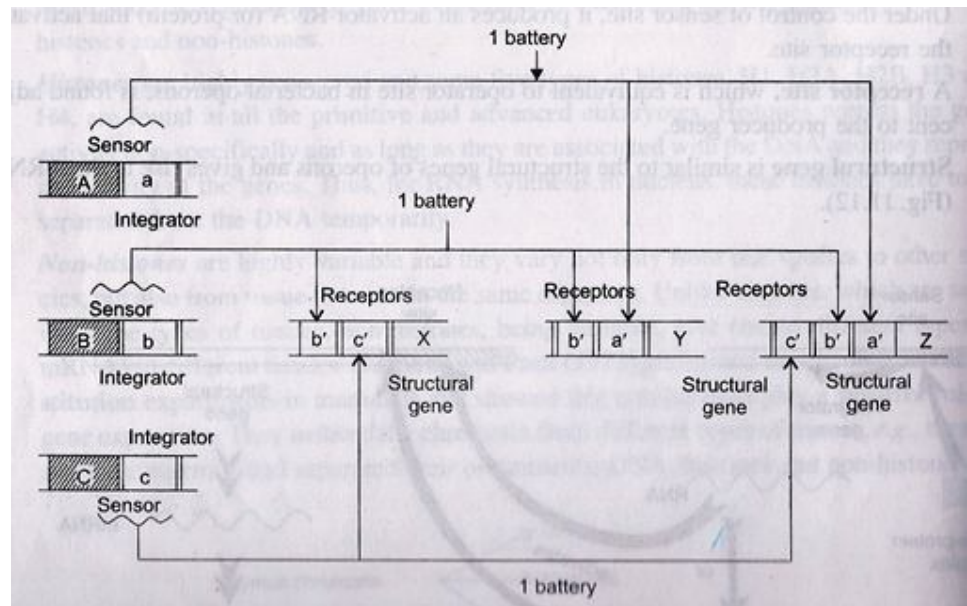

**Fig.- 16.4- Gene Battery Model**

The sensor site is recognized by agents like proteins and hormones which modifies the gene expression.

e.g. Hormone protein complex may bind to sensor site and induce transcription of integrator gene the sensor site & receptor site help in recognition without taking part in RNA synthesis and producer or integrator genes are involved in RNA Synthesis. When a specific substrate binds to sensor, it becomes activated and allows transcription of the adjacent integrator gene to produce activator RNA. Subsequently, the activator RNA binds to receptor locus which is located either same or other chromosome. Activator RNA Binding to the receptor results in the transcription of structure gene to yield mRNA.

### **Post Transcriptional Regulation-**

**Feedback inhibition-** In case the end product of a biosynthesis pathway is not utilized. It accumulates inside the cell and stops the further synthesis of that product. This called as feedback inhibition of the gene action. The inhibition is caused by the binding of accumulated end product. E.g. UMBARGER (1961) has demonstrated that isoleucine synthesis from E. coli can be inhibited, if some Isoleucine is added to the medium.

By the binding of Isoleucine to the enzyme, the enzyme is inactive. This phenomenon of inhibition to the enzyme is known as allosteric interaction.

### **Regulation At Translation Level –**

Gene GCN4 (gene for general control of nitrogen metabolism) in yeast has been found regulated primarily at translation level. Konzak (1983) proposed a hypothesis for translation in eukaryotes. According to which, a 40s subunit of ribosome along with methionine tRNA moves down the MRNA from 5' end until it finds out first AUG, so that 60s subunit Join and translation begin. This hypothesis is applicable very clearly to mRNA of GCN4 of yeast. This mRNA has 577 nucleotides long un-translated sequence at 5 end and it has AUG codons upstream of the real AUG Codon. Each false codon is followed by a termination codon.

Experimental studies have shown that if the starting 250 codons which includes false AUG codons are deleted, a greatly increased rate of translation is found.

Such an increase suggests that these false AUG codons limit or regulate the translation.

### **Post Translational Processing Of Polyproteins-**

Polyproteins are polypeptides which contain repeated sequence of smaller polypeptides. A Single polyprotein contain more than one separate polypeptide. e.g. the gene for polyprotein proopiomelanocortin (POMC) codes for several proteins functions. POMC shows tissue- specific processing. In the anterior lobe of pituitary it is first cleaved to yield an N- terminal fragment and c

terminal  $\beta$  lipoprotein. The N terminal fragment is further cleaved to release the ACTH hormone.

On the other hand, in the intermediate lobe of the pituitary gland the ACTH and  $\beta$  Lipoprotein are processed further. The ACTH is cleaved to yield a melanotropin ( $\alpha$ -MSH) While the  $\beta$  Lipoprotein is further cut to produce  $\beta$  endorphin. Thus a single gene may give rise to different functional polypeptides in different tissues due to a variation in the protein processing. In general polyproteins are cleaved to yield functional proteins of < 40 amino acid each.

#### **RNA Interference (RNAi) -**

RNAi have a more widespread and unanticipated role in gene regulation in Eukaryotes. This is new mode of gene regulation. Several types of very short RNAs repress or silence expression of genes with homology to those short RNAs. This silencing called RNAi (RNA interference). Some times by inhibiting translation of the mRNA, and in yet others by transcriptional silencing of the promoter that directs expression of that mRNA. These short RNA are generated by special enzymes from longer double stranded RNAs (dsRNAs) of various origins.

[The small RNAs have different names depending on their origin. Those made artificially or produced in vivo from dsRNA precursors are typically called small interference (SiRNA). Another group of regulatory RNAs are the micro RNAs (MiRNAs)]

These small RNA inhibit expression of homologous target genes in three ways they trigger destruction of the mRNA encoded by the target gene. They inhibit translation of the mRNA or they induce chromatin modification within the target gene and there by silence its transcription. In this process one complex 'RISC' which contains SiRNA & MiRNA, Various proteins including a membrane of the Argonaut family.

The SiRNA or MiRNA must be denatured to give a guide RNA. The strand that gives the RISC specificity and passenger RNA, usually gets discarded. The resulting complex, the mature RISC is then directed to target RNAs containing sequences complementary to the guide RNA. These target RNAs are degraded or their translation is inhibited. Typically the choice depends in part on how closely the guide RNA matches the target mRNA. If the sequence is highly complementary the target is degraded; if the match is not as good (there are several base pairing mismatches) the response is more often inhibition of translation. In those cases where the target RNA is degraded, Argonaut is the

catalytic subunit the carries out the initial mRNA cleavage, for this reason Argonaut is often called 'slicer' and mRNA cleavage is called slicing

---

## 16.4 Summary

---

Many mechanisms regulate gene activity. The goal is to express genes only when needed. The catabolic machinery needed to metabolise lactose only when lactose is there like wise tryptophane only needs to be made when it is not present in cells. For this Jacob and monad suggested operon concept. In eukaryotes positive regulation is more common than negative. Most of the genes regulated at transcriptional level. Britin and Devidson suggest Gene Battery model to explain regulation in Eukaryotes.

---

## 16.5 Exercise

---

1. Give examples of Positive and Negative regulation.
  2. How does the presence of Glucose in medium affects enzyme synthesis for utilization of lactose.?
  3. Describe transcriptional attenuation.
  4. Describe Gene battery model.
  5. Differentiate between Prokaryotic and eukaryotic gene regulation.
- 

## 16.6 Glossary

---

- Induction
  - Repression
  - Operator
  - Operon
  - Housekeeping Genes
  - Attenuation
  - Gene Battery
  - RNAi
- 

## 16.7 References

---

- Freifelder D., Molecular Biology, Narosa Publishing House, New Delhi (1995)

- Alberts B., Bray D., Johnson A., Lewis J., Raff M., Roberts K. and Walter P., Essential of cell biology, Garland Publishing, Inc. New York (1997)